

Customer Information Sheet

DRAWING No.: R630X-02

SHEET 2 OF 2

IF IN DOUBT - ASK

©

NOT TO SCALE

THIRD ANGLE PROJECTION

ALL DIMENSIONS IN mm

OBSOLETE

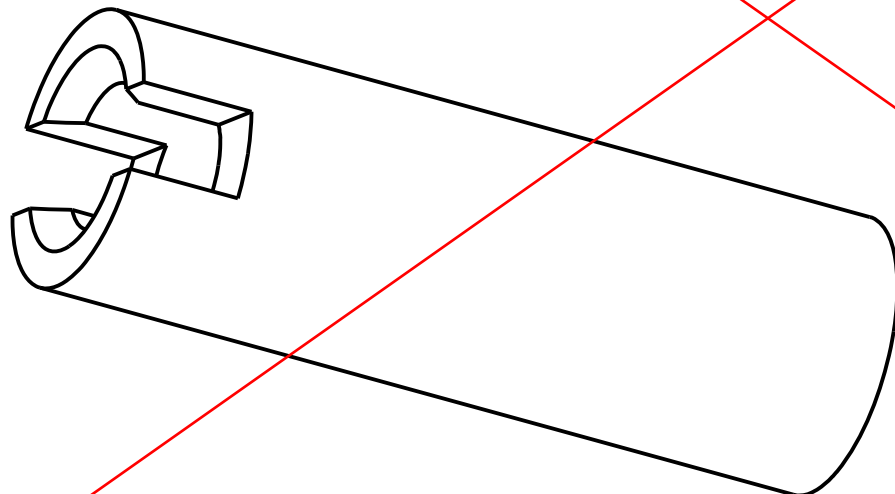
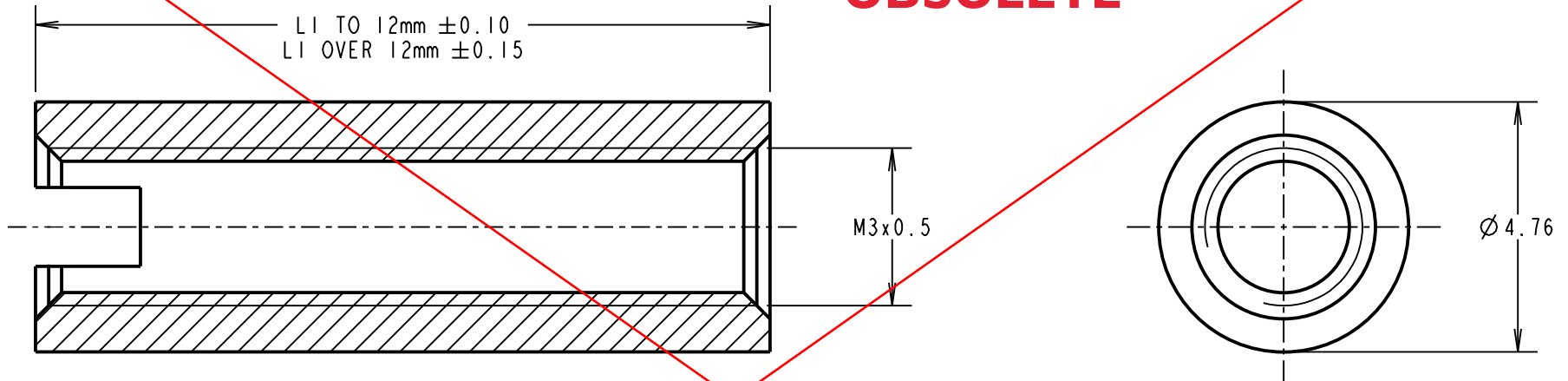

PART No.	LI
R6302-02	6.00
R6303-02	8.00
R6304-02	10.00
R6305-02	12.00
R6306-02	14.00
R6307-02	16.00
R6308-02	18.00

MGP	2	18.04.13	12015
NAME	ISS.	DATE	C/NOTE
APPROVED: MGP			
CHECKED: SF			
DRAWN: J.CLAY			
CUSTOMER REF.:			
ASSEMBLY DRG:			

HARWIN

www.harwin.com
technical@harwin.com

THIS DRAWING AND ANY INFORMATION OR DESCRIPTIVE MATTER SET OUT HEREON ARE CONFIDENTIAL AND COPYRIGHT PROPERTY OF THE HARWIN GROUP AND MUST NOT BE DISCLOSED, LOANED, COPIED OR USED FOR MANUFACTURING, TENDERING OR FOR ANY OTHER PURPOSE WITHOUT THEIR WRITTEN PERMISSION.

TOLERANCES
 X. = ±1mm
 X.X = ±0.25mm
 X.XX = ±0.10mm
 X.XXX = ±0.01mm
 ANGLES = ±5°
 UNLESS STATED

MATERIAL:
 BRASS
 CW614N M TO BS EN 12164
 (CuZn39Pb3)
FINISH: NICKEL
S/AREA: mm²

TITLE:
 M3 CIRCULAR SLOTTED
 FEMALE SPACER

DRAWING NUMBER:
 R630X-02

SHT
2 OF 2