

STRAIGHT BULKHEAD JACK PANEL SEAL
REAR MOUNT CLAMP TYPE - CABLE 2.6/50+75

R143.324.207
SERIES TNC

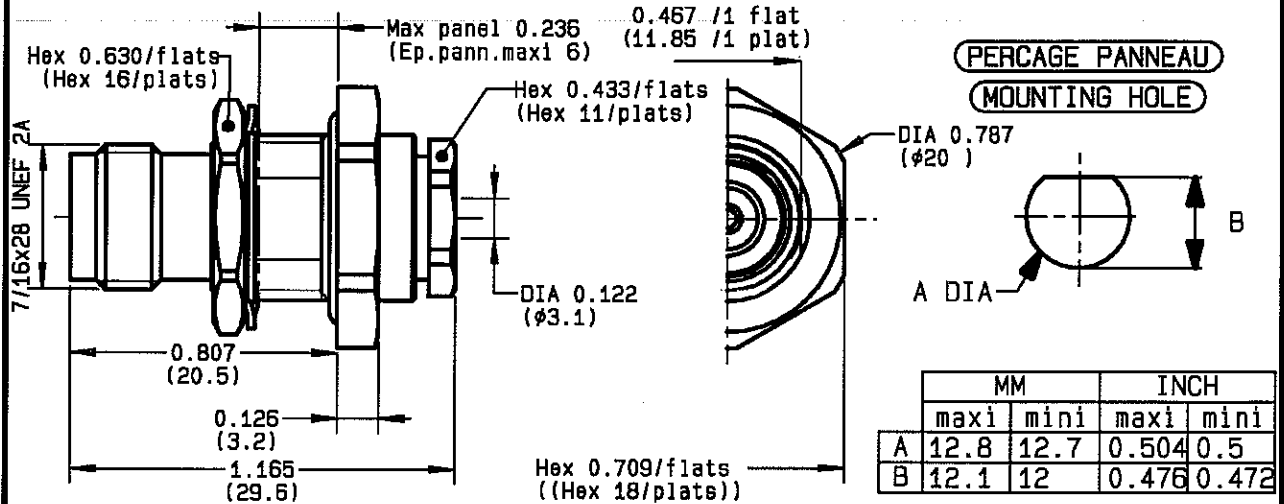

NOMINAL IMPEDANCE	50 Ω
FREQUENCY RANGE	0-11 GHz
TEMPERATURE RATING	-65/+165 °C
V.S.W.R	1.40 + x F(GHz)Maxi
RF INSERTION LOSS	0.06 √F(GHz) dB Maxi
VOLTAGE RATING	335 Veff Maxi
DIELECTRIC WITHSTANDING VOLTAGE	1000 Veff Mini
INSULATION RESISTANCE	5000 MΩMini
HERMETIC SEAL	NA Atm.cm ³ /s
LEAKAGE (pressurized only)	IP67
MECHANICAL DURABILITY	500 Cycles
WEIGHT	gr
SPECIFICATION	

CABLES : **KX 22A**
RG 179
RG 187
RG 188
RG 316

OTHERS CHARACTERISTICS

CABLE RETENTION	40 N Mini
CENTER CONTACT RETENTION	
Axial force - mating end	27 N Mini
Axial force - opposite end	27 N Mini
Torque	NA cm.N Mini
RECOMMENDED TORQUES	
Mating	NA cm.N
Panel nut	370 cm.N
Clamp nut	450 cm.N

CONNECTOR PARTS	MATERIALS	FINISH	(all values are given in micrometers)
BODY	BRASS	BBR 2	
OUTER CONTACT			
CENTER CONTACT	BERYLLIUM COPPER	GOLD 0.5 OVER NICKEL 2	
INSULATOR	PTFE	-	
GASKET		-	
OTHERS PIECES		BBR 2	

ISSUE	CREATION DATE	FILE PART-NUMBER
0725 B00	06/10/1997	97-0400-577



RAFFAELI

The information given here is subject to change without notice. Design changes may be in order to improve the product.

Connect to the future



R143.324.207

ISSUE 0725 B00 SERIES TNC

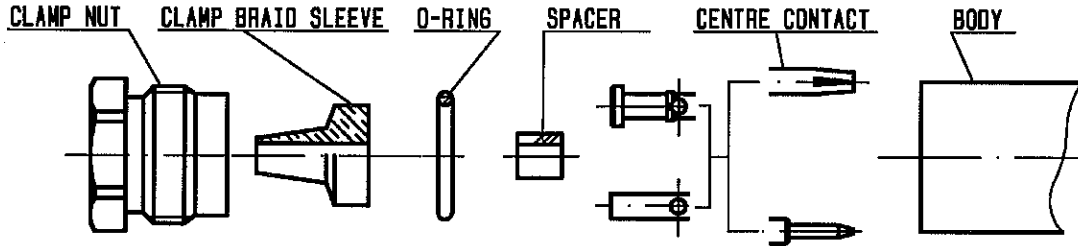

①

Slide the clamp nut onto cable .
Strip the cable .
Cut the jacket (2 slots)
if necessary .
-

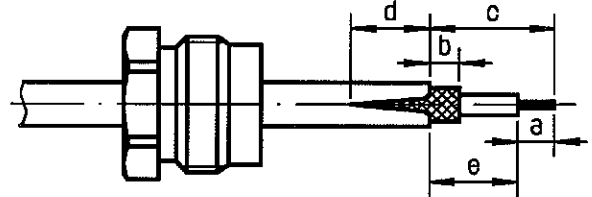

Stripping	a	b	c	d	e
inch	0.157	0.079	0.354	0	0.197
mm	4	2	9		5

②

Slide the clamp braid sleeve between
cable dielectric and braid .
Cut the braid flush with the clamp
braid sleeve .
Slide the spacer onto cable .
-
-
-

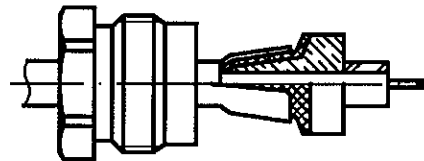

③

Solder the cable inner conductor into
center contact :
Slide the back nut over the clamp
assembly .
-
-
-
-

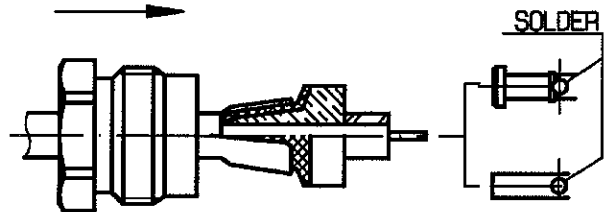

④

Mount the O-ring into the connector .
Screw sub-assembly into the connector
body .
(recommended coupling torque 39.82 in.lb)
-

