

**STRAIGHT JACK SQUARE FLANGE**

**CRIMP TYPE - CABLE 5/50 S**

**R141.292.000**

Series : BNC

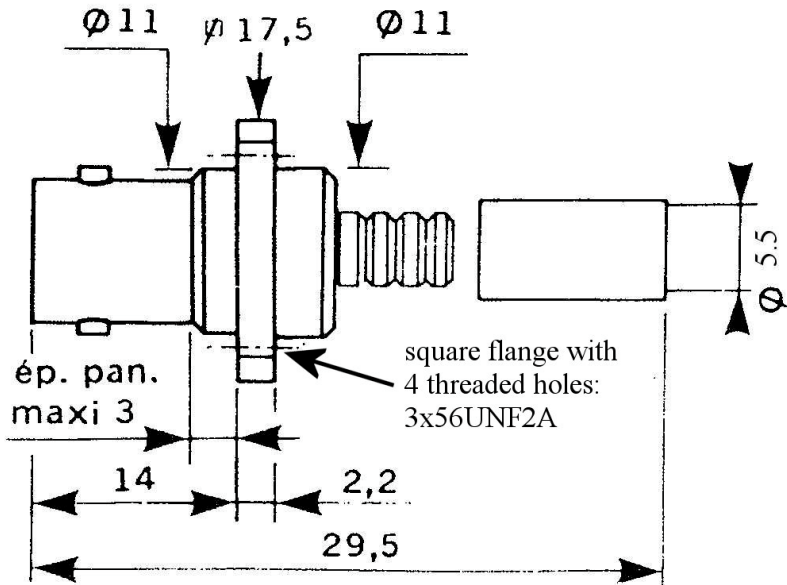

Perçage panneau

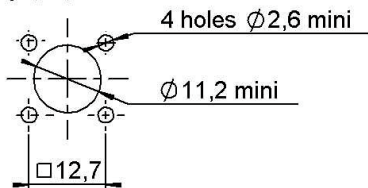

All dimensions are in mm.

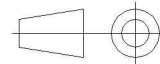

COMPONENTS	MATERIALS	PLATINGS (µm)
<b>BODY</b>	<b>BRASS</b>	<b>NICKEL 2</b>
<b>CENTER CONTACT</b>	<b>BERYLLIUM COPPER</b>	<b>GOLD 0.5 OVER NICKEL 2</b>
<b>OUTER CONTACT</b>	-	-
<b>INSULATOR</b>	<b>PTFE</b>	-
<b>GASKET</b>	-	-
<b>OTHERS PARTS</b>	<b>BRASS</b>	<b>NICKEL 2</b>
-	-	-
-	-	-

**Issue : 0502 D**

In the effort to improve our products, we reserve the right to make changes judged to be necessary.



**STRAIGHT JACK SQUARE FLANGE**

**R141.292.000**

**CRIMP TYPE - CABLE 5/50 S**

Series : **BNC**

**PACKAGING**

Standard	Unit	Other
<b>100</b>	<b>'W' option</b>	<b>Contact us</b>

**SPECIFICATION**

**ELECTRICAL CHARACTERISTICS**

Impedance		<b>50</b> Ω
Frequency		<b>0-4</b> GHz
VSWR	<b>1.3 +</b>	<b>0.000</b> x F(GHz) Maxi
Insertion loss		- √F(GHz) dB Maxi
RF leakage	- (	- F(GHz)) dB Maxi
Voltage rating		- Veff Maxi
Dielectric withstanding voltage		<b>1500</b> Veff mini
Insulation resistance		<b>5000</b> MΩ mini

**CABLE ASSEMBLY**

Stripping	a	b	c	d	e	f
mm	4.00	8.50	15.0	0.00	11.0	0.00

Assembly instruction : **Crimp 02**

Recommended cable(s)  
 KX 15  
 RG 141  
 RG 58

Characteristics indicated on this data sheet are those that can be achieved with the highest performance cable. Intrinsic limitations of the cable may diminish the performance of the assembly

Cable retention

- pull off **91** N mini  
 - torque **NA** N.cm

**MECHANICAL CHARACTERISTICS**

Center contact retention		
Axial force – Mating end		<b>27</b> N mini
Axial force – Opposite end		<b>27</b> N mini
Torque		<b>NA</b> N.cm mini

**TOOLING**

Part Number	Description	Hexagon
.	.	.
R282.223.000	CRIMPING TOOL	1.73-5.41
R282.293.000	CRIMPING TOOL	-
R282.235.011	CRIMPING DIES	1.73-5.41

Recommended torque		
Mating		<b>NA</b> N.cm
Panel nut		<b>NA</b> N.cm
Clamp nut		<b>NA</b> N.cm
A/F clamp nut		<b>0.000</b> mm

Mating life		<b>500</b> Cycles mini
Weight		<b>12.000</b> g

**OTHERS CHARACTERISTICS**

-

**ENVIRONMENTAL**

Operating temperature		<b>-65/+165</b> °C
Hermetic seal		- Atm.cm3/s
Panel leakage		-

Issue : **0502 D**

In the effort to improve our products, we reserve the right to make changes judged to be necessary.

