

**STRAIGHT FLOATING BULKHEAD JACK**

**R128.293.702**

**SOLDER TYPE-CABLE .085**

Series : **BMA-COM**

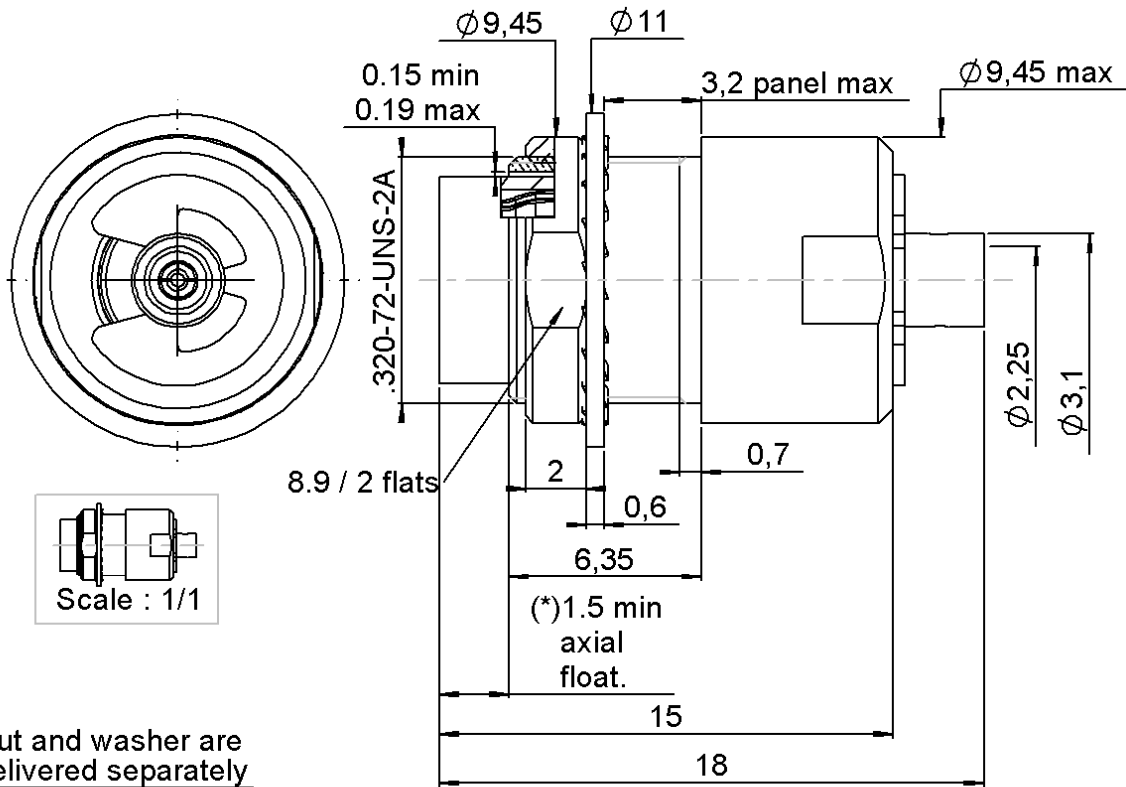

Nut and washer are delivered separately

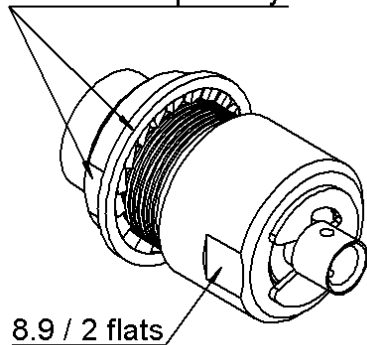

Recommended mounting hole

(\*) Recommended axial float mount for best electrical performance: 0.51 +/- 0.25 mm (.020" +/- .010)

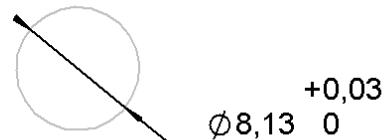

All dimensions are in mm.

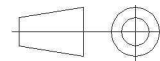

COMPONENTS	MATERIALS	PLATING ( $\mu\text{m}$ )
BODY	BRASS	BBR2
CENTER CONTACT	BERYLLIUM COPPER	NPGR
OUTER CONTACT	BERYLLIUM COPPER	NPGR
INSULATOR	-	
GASKET	-	
OTHERS PARTS	BRASS	BBR2
-	-	-
-	-	-

Issue : 0941 D

In the effort to improve our products, we reserve the right to make changes judged to be necessary.



**STRAIGHT FLOATING BULKHEAD JACK**

**R128.293.702**

**SOLDER TYPE-CABLE .085**

Series : **BMA-COM**

**PACKAGING**

Standard	Unit	Other
<b>100</b>	<b>W</b>	<b>Contact us</b>

**SPECIFICATION**

**ELECTRICAL CHARACTERISTICS**

Impedance		<b>50</b> Ω
Frequency		<b>DC-18</b> GHz
VSWR	<b>1.05</b> +	<b>0,0100</b> x F(GHz) Maxi
Insertion loss		<b>0.03</b> √F(GHz) dB Maxi
RF leakage	- (	<b>90</b> - F(GHz)) dB Maxi
Voltage rating		<b>350</b> Veff Maxi
Dielectric withstanding voltage		<b>1000</b> Veff mini
Insulation resistance		<b>5000</b> MΩ mini

**CABLE ASSEMBLY**

Stripping	a	b	c	d	e	f
mm	1,78	0,00	0,00	0,00	0,00	0,00

Assembly instruction :

Recommended cable(s)  
 RG 405  
 KS 1

**MECHANICAL CHARACTERISTICS**

Center contact retention		
Axial force – Mating end		<b>18</b> N mini
Axial force – Opposite end		<b>18</b> N mini
Torque		<b>NA</b> N.cm mini

Characteristics indicated on this data sheet are those that can be achieved with the highest performance cable. Intrinsic limitations of the cable may diminish the performance of the assembly

Cable retention

- pull off		<b>136</b> N mini
- torque		<b>NA</b> N.cm

**TOOLING**

Recommended torque		
Mating		<b>NA</b> N.cm
Panel nut		<b>NA</b> N.cm
Clamp nut		<b>NA</b> N.cm
A/F clamp nut		<b>0,0000</b> mm
Mating life		<b>1000</b> Cycles mini
Weight		<b>3,7500</b> g

Part Number	Description	Hexagon
.	.	.
R282.062.000	POINTER GAUGE	
R282.740.000	SOLDERING MOUNTING	
R282.051.000	STRIPPING TOOL	
R282.860.130	SOLDER POSITIONER BMA	

**ENVIRONMENTAL**

Operating temperature		<b>-65/+105</b> °C
Hermetic seal		<b>NA</b> Atm.cm3/s
Panel leakage		<b>IP54*</b>

**OTHER CHARACTERISTICS**

\*Mated with waterproof male connector

**It is recommended to use a service loop to facilitate the float features of the connector**

Issue : **0941 D**

In the effort to improve our products, we reserve the right to make changes judged to be necessary.



**STRAIGHT FLOATING BULKHEAD JACK**

**R128.293.702**

**SOLDER TYPE-CABLE .085**

Series : BMA-COM

**COMPONENT**

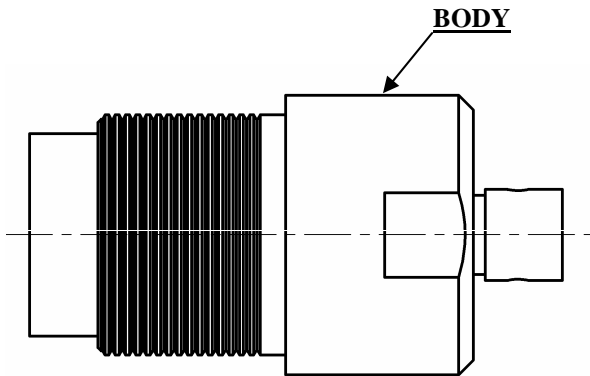

**STRIPPING DIMENSION**

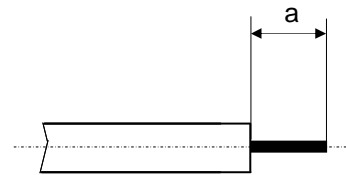

We recommend a cable thermal preconditioning before assembly

1

- Strip the cable with the cable stripping tool.
- Trim the cable inner conductor with the trimmer.
- Clean the cable

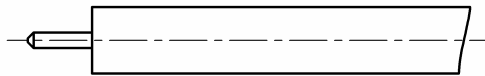

2

- Introduce the cable into the body until contact with the body shoulder.
- Place the sub-assembly on assembly jig with the positioner and tighten it.
- Solder body on the cable.
- Let assembly cool down before removing it from the jig.

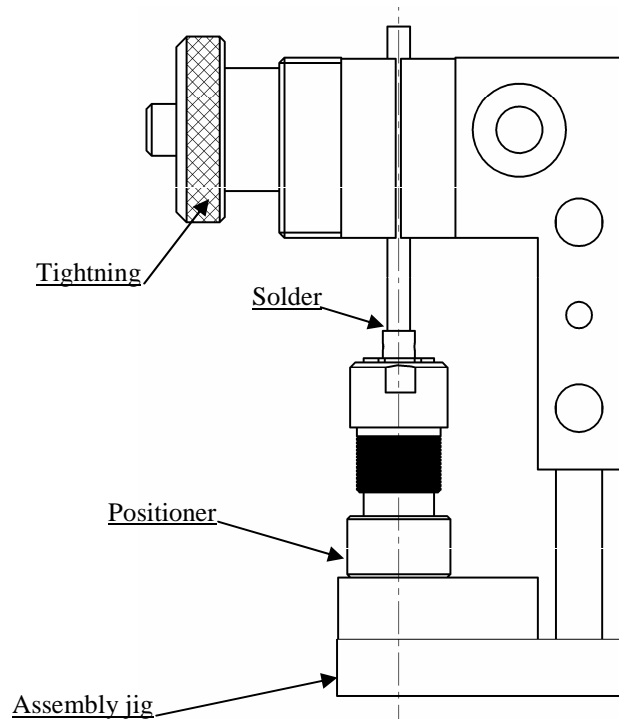

Issue : 0941 D

In the effort to improve our products, we reserve the right to make changes judged to be necessary.

**STRAIGHT FLOATING BULKHEAD JACK**

**R128.293.702**

**SOLDER TYPE-CABLE .085**

Series : **BMA-COM**

**TRAY 100 CAVITIES**

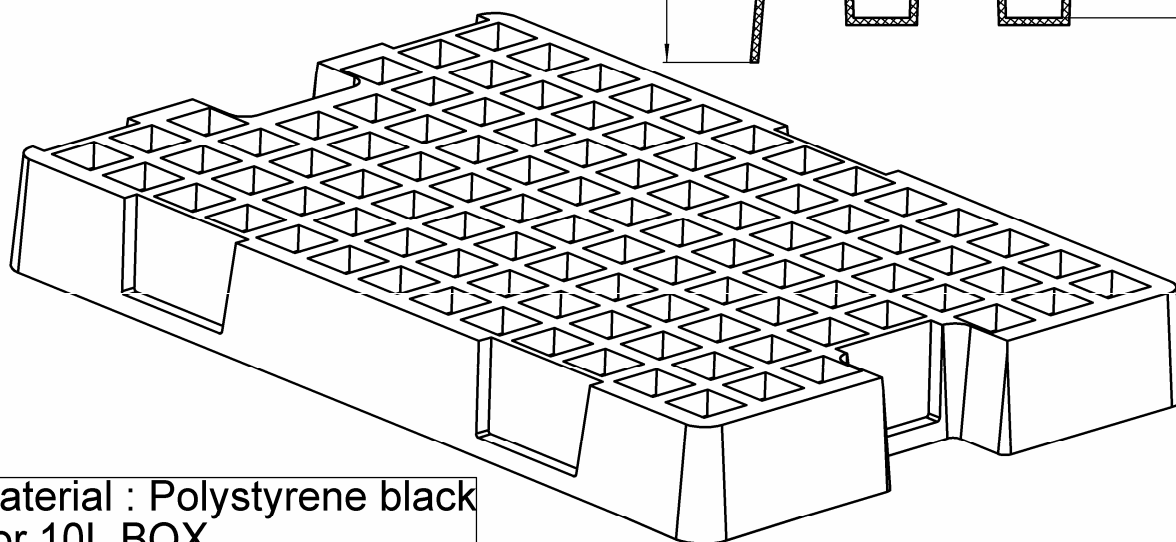
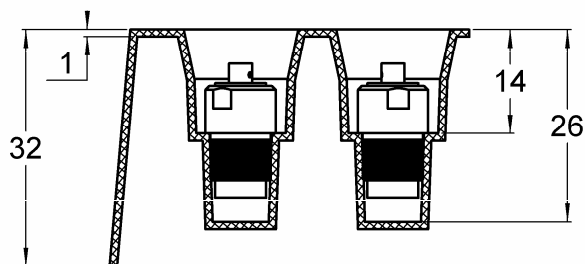
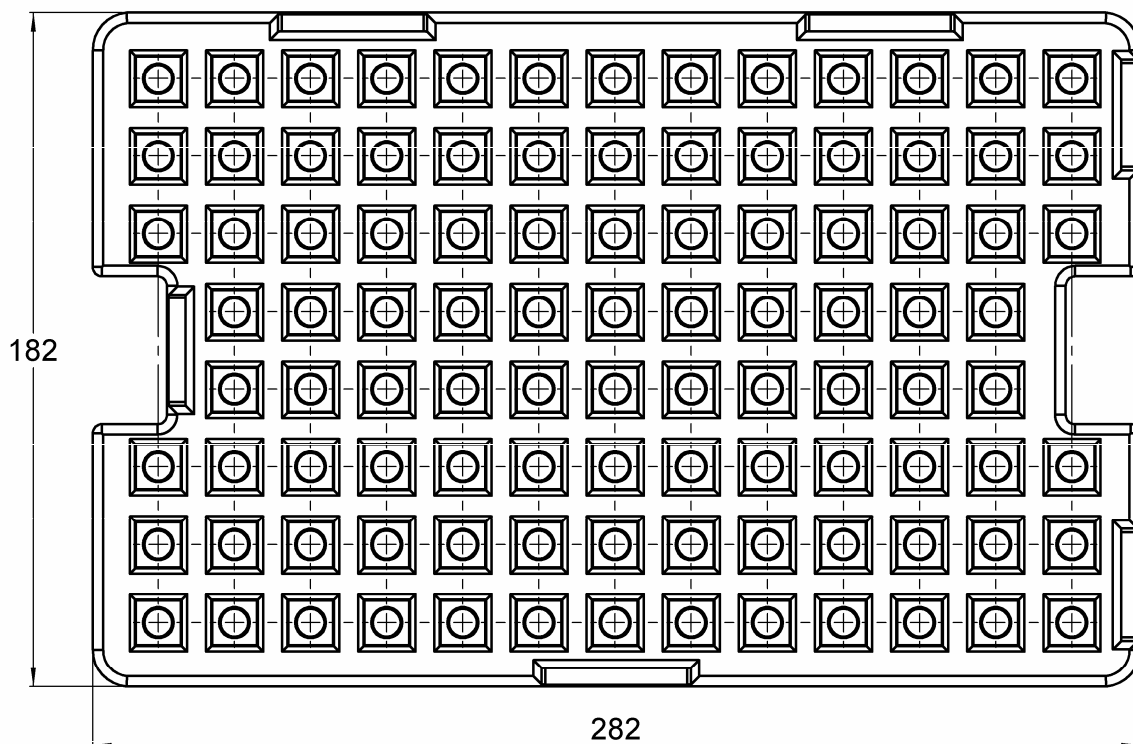

**Material : Polystyrene black**  
**For 10L BOX**

**Issue : 0941 D**

In the effort to improve our products, we reserve the right to make changes judged to be necessary.

