

STRAIGHT PLUG SOLDER TYPE CAPTIVE CONT.

R127.800.001

CABLE .085 MICROPOROUS

Series : SMA2.9

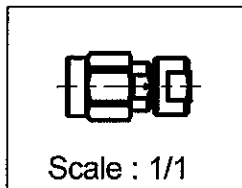
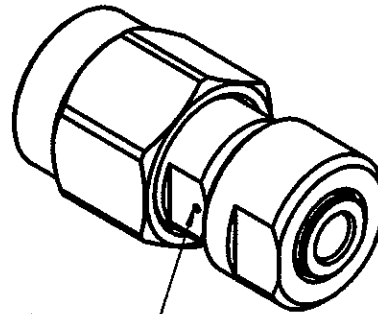
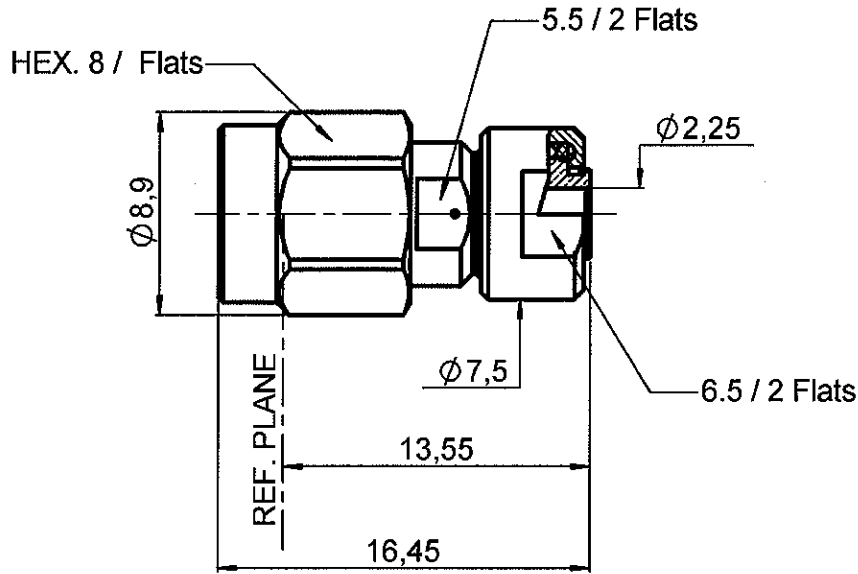

1 degassing hole dia 0.3

All dimensions are in mm.

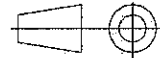

COMPONENTS	MATERIALS	PLATINGS (µm)
BODY	STAINLESS STEEL	PASSIVATED .
CENTER CONTACT	BERYLLIUM COPPER	GOLD 1.3 OVER NICKEL 2
OUTER CONTACT	BRASS	GOLD 1.3 OVER NICKEL 2
INSULATOR	ULTEM1000	
GASKET	SILICONE RUBBER	
OTHERS PARTS	BRASS	GOLD 0.2 OVER NICKEL 2
-	-	-
-	-	-

Issue : 0521 B

In the effort to improve our products, we reserve the right to make changes judged to be necessary.



STRAIGHT PLUG SOLDER TYPE CAPTIVE CONT.

R127.800.001

CABLE .085 MICROPOROUS

Series : SMA2.9

PACKAGING

Standard	Unit	Other
1	-	Contact us

SPECIFICATION

ELECTRICAL CHARACTERISTICS

Impedance		50 Ω
Frequency		0-40 GHz
VSWR	1.05 +	0.005 x F(GHz) Maxi
Insertion loss		0.03 √F(GHz) dB Maxi
RF leakage	- (90 - F(GHz) dB Maxi
Voltage rating		350 Veff Maxi
Dielectric withstanding voltage		750 Veff mini
Insulation resistance		5000 MΩ mini

CABLE ASSEMBLY

Stripping	a	b	c	d	e	f
mm	1.78	0.00	0.00	0.00	0.00	0.00

Assembly instruction :

Recommended cable(s)
UT 85-LL

Characteristics indicated on this data sheet are those that can be achieved with the highest performance cable. Intrinsic limitations of the cable may diminish the performance of the assembly

Cable retention

- pull off **200** N mini
- torque **11.28** N.cm

MECHANICAL CHARACTERISTICS

Center contact retention		
Axial force – Mating end	27	N mini
Axial force – Opposite end	27	N mini
Torque	NA	N.cm mini

TOOLING

Part Number	Description	Hexagon
R282.120.220	SMA 2.9 TOOLBOX	
. Or spare tools	-	
R282.740.000	SOLDERING MOUNTING	
R282.744.190	SOLDERING POSITIONER	
R282.059.010	CABLE HOLDER	
R282.051.030	STRIPPING TOOL .085 MIPRO.	
R282.061.030	POINTER GAUGE	
R282.323.000	TORQUE WRENCH	

Recommended torque		
Mating	90	N.cm
Panel nut	NA	N.cm
Clamp nut	100	N.cm
A/F clamp nut	6.500	mm

Mating life	500	Cycles mini
Weight	3.950	g

ENVIRONMENTAL

Operating temperature	-65/+165	°C
Hermetic seal	NA	Atm.cm3/s
Panel leakage	NA	

OTHERS CHARACTERISTICS

Issue : 0521 B

In the effort to improve our products, we reserve the right to make changes judged to be necessary.



RADIALL®

STRAIGHT PLUG SOLDER TYPE CAPTIVE CONT.

R127.800.001

CABLE .085 MICROPOROUS

Series : SMA2.9

COMPONENTS

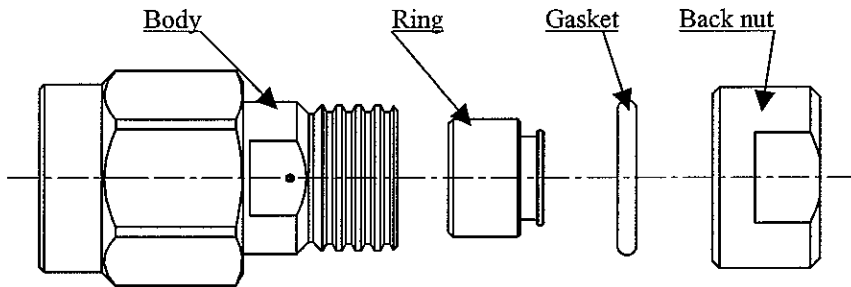

STRIPPING DIMENSION

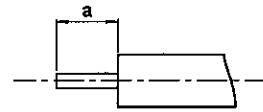

SOLDERING THE RING

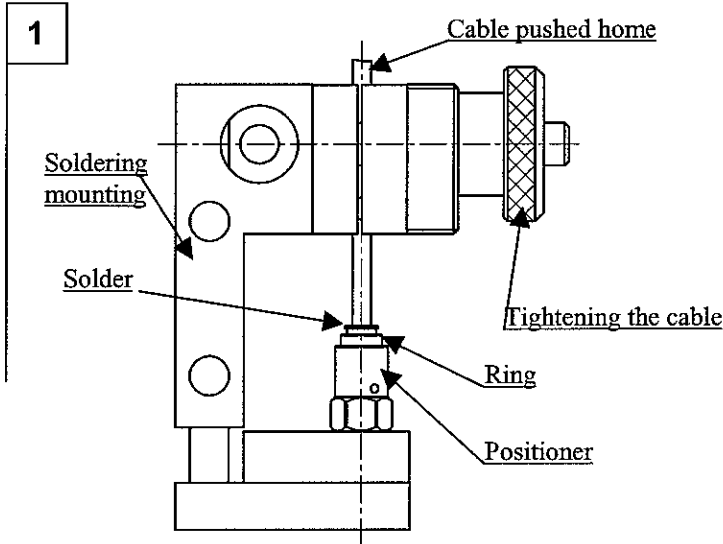

- Cut the cable to the desired length.
- Put the gasket until it bottoms against the nut (see figure paragraph 4 for the position).
- Slide the back nut onto the cable before soldering operation.
- Place the cable in the soldering mounting.
- Fit the ring and positioner on the cable, and tighten.
- Solder the ring on the cable.
- Clean the soldering.

STRIPPING THE CABLE

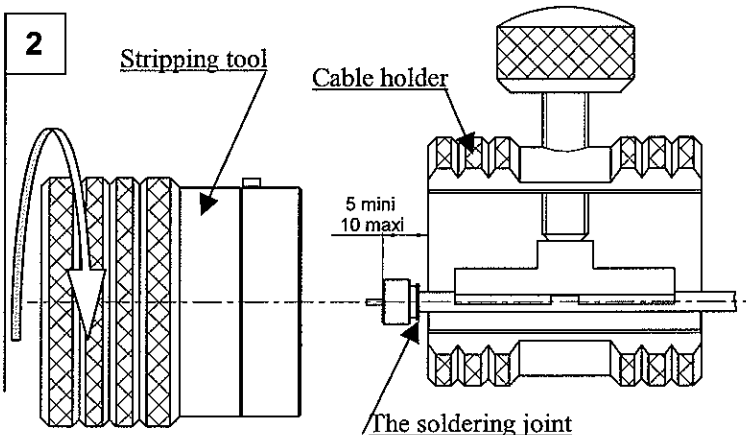

- Immobilize the cable using the thumb screw on the cable holder. Do not tighten the soldered joint.
- Check the position of cable in the v form of cable holder.
- Position the stripping tool opposite the cable holder.
- Turn and push both elements with respect to each other. Once they are bearing against each other, pull without turning.
- Remove the residue of dielectric around the inner cable with a scalpel.

Issue : 0521 B

In the effort to improve our products, we reserve the right to make changes judged to be necessary.



STRAIGHT PLUG SOLDER TYPE CAPTIVE CONT.

R127.800.001

CABLE .085 MICROPOROUS

Series : SMA2.9

CABLE POINTER

3

- Position the pointer gauge opposite the cable holder.
- Turn and push both elements with respect to each other until fully home.
- Remove the cable from the cable holder.
- Check the trimming.

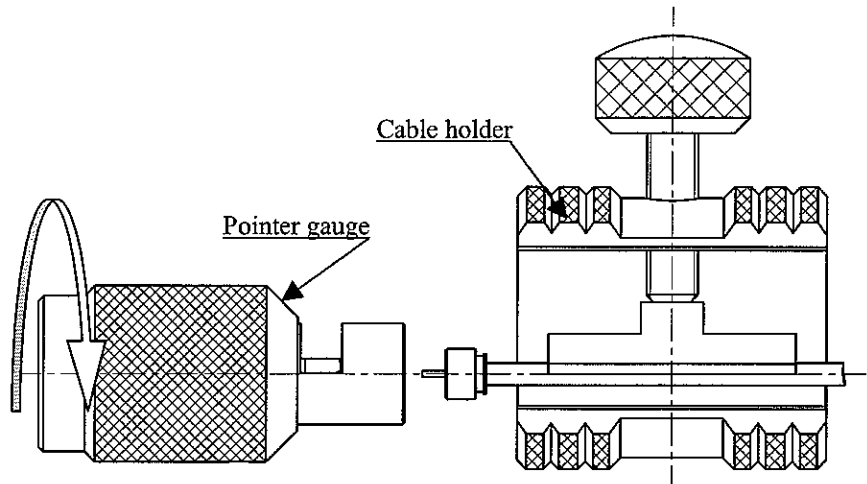

FITTING ON CONNECTOR

4

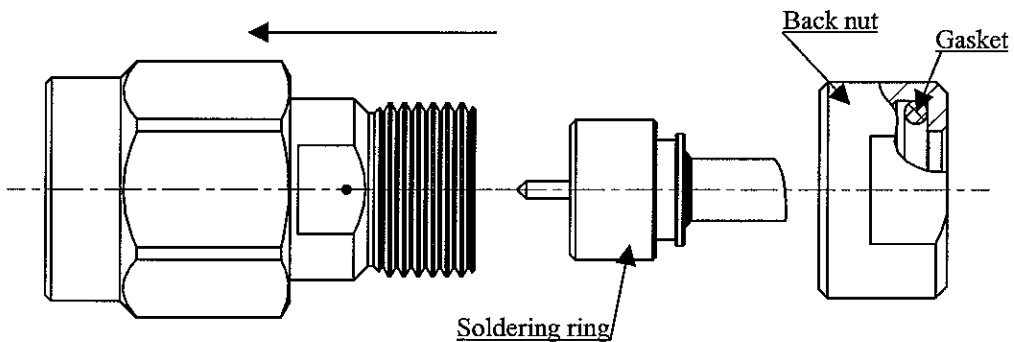

-Fit the soldered ring in the body housing.

TIGHTENING OF BACK NUT

5

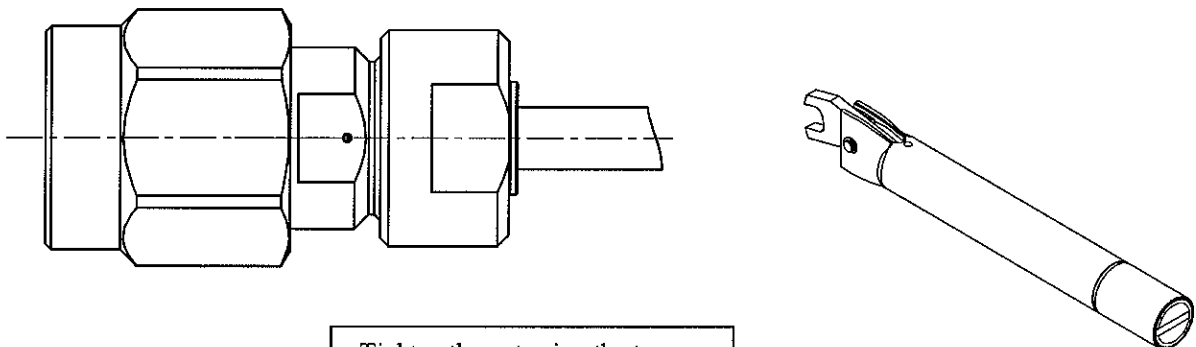

-Tighten the nut using the torque wrench(8.67 Inchs/Lbs).

Issue : 0521 B

In the effort to improve our products, we reserve the right to make changes judged to be necessary.

