

**STRAIGHT PLUG CRIMP OR SOLDER TYPE**

**R125.078.001**

**CABLE 5/50 D**

Series : SMA

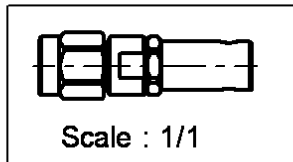
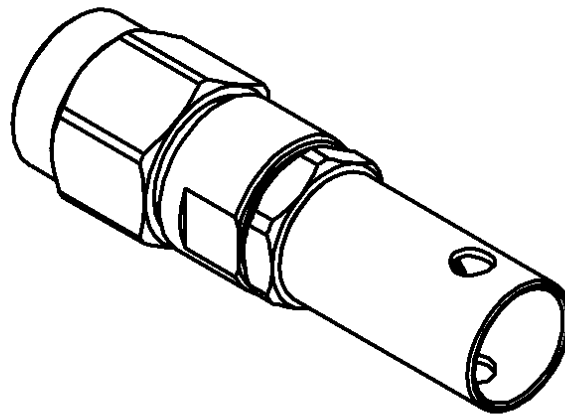
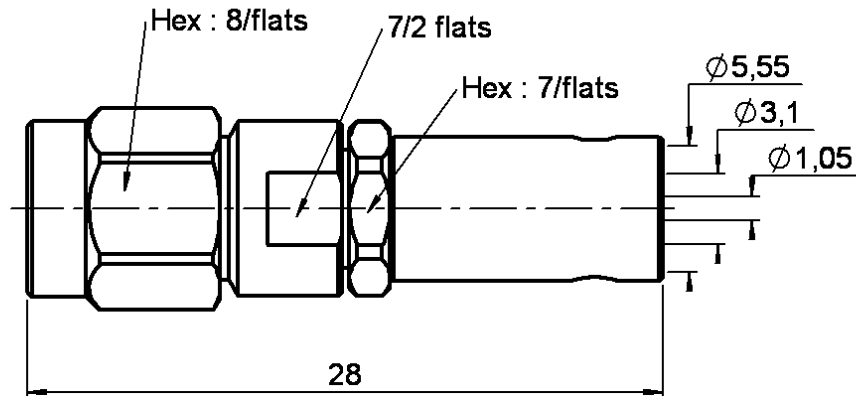

All dimensions are in mm.



COMPONENTS	MATERIALS	PLATINGS (µm)
BODY	STAINLESS STEEL	PASSIVATED .
CENTER CONTACT	BRASS	GOLD 1.3 OVER NICKEL 2
OUTER CONTACT	-	-
INSULATOR	PTFE	-
GASKET	SILICONE RUBBER	-
OTHERS PARTS	STAINLESS STEEL	PASSIVATED .
-	-	-
-	-	-

Issue : 0220 C

In the effort to improve our products, we reserve the right to make changes judged to be necessary.



**STRAIGHT PLUG CRIMP OR SOLDER TYPE**

**R125.078.001**

**CABLE 5/50 D**

Series : SMA

**PACKAGING**

Standard	Unit	Other
<b>100</b>	<b>'W' option</b>	<b>Contact us</b>

**SPECIFICATION**

**ELECTRICAL CHARACTERISTICS**

Impedance		<b>50</b> Ω
Frequency		<b>0-12.4</b> GHz
VSWR	<b>1.15</b> +	<b>0.010</b> x F(GHz) Maxi
Insertion loss		<b>0.06</b> √F(GHz) dB Maxi
RF leakage	- (	<b>60</b> - F(GHz)) dB Maxi
Voltage rating		<b>335</b> Veff Maxi
Dielectric withstanding voltage		<b>1000</b> Veff mini
Insulation resistance		<b>5000</b> MΩ mini

**CABLE ASSEMBLY**

Stripping	a	b	c	d	e	f
mm	3.50	7.00	13.5	0.00	10.0	0.00

Assembly instruction : **Crimp 10**

Recommended cable(s)  
 RG 223  
 RG 142  
 RG 400  
 KX 23  
 RG 142 FTX

Cable retention  
 - pull off **204** N mini  
 - torque **NA** N.cm

**MECHANICAL CHARACTERISTICS**

Center contact retention		
Axial force – Mating end		<b>27</b> N mini
Axial force – Opposite end		<b>27</b> N mini
Torque		<b>NA</b> N.cm mini

**TOOLING**

Part Number	Description	Hexagon
.	.	.
R282.235.011	CRIMPING DIES	5.41
R282.293.000	CRIMPING TOOL	-
R282.223.000	CRIMPING TOOL	5.41

Recommended torque		
Mating		<b>100</b> N.cm
Panel nut		<b>NA</b> N.cm
Clamp nut		<b>100</b> N.cm
A/F clamp nut		<b>7.000</b> mm

Mating life		<b>500</b> Cycles mini
Weight		<b>5.243</b> g

**OTHERS CHARACTERISTICS**

-

**ENVIRONMENTAL**

Operating temperature		<b>-65/+165</b> °C
Hermetic seal		<b>NA</b> Atm.cm3/s
Panel leakage		<b>NA</b>

Issue : 0220 C

In the effort to improve our products, we reserve the right to make changes judged to be necessary.

