

STRAIGHT PLUG CRIMP TYPE

R125.072.081

CABLE 2.6/50 D

Series : SMA

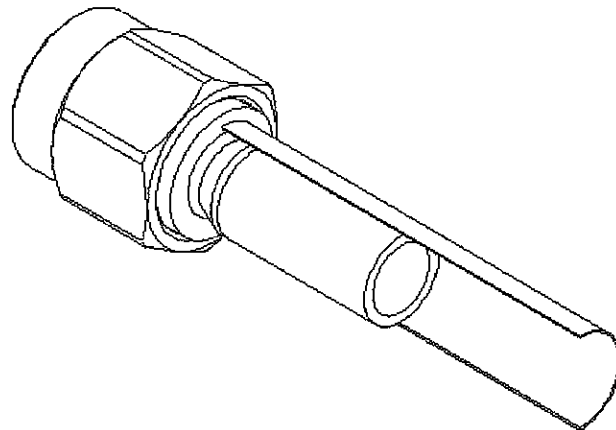
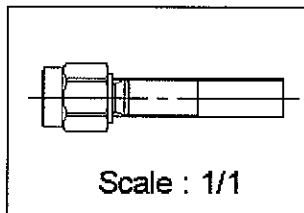
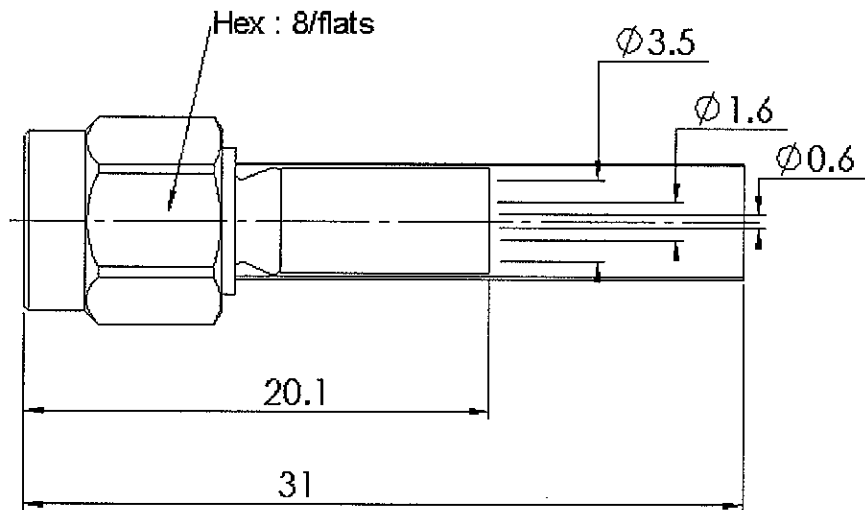

All dimensions are in mm.

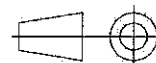

COMPONENTS	MATERIALS	PLATINGS (µm)
BODY	STAINLESS STEEL	PASSIVATED .
CENTER CONTACT	BRASS	GOLD 1.3 OVER NICKEL 2
OUTER CONTACT	-	-
INSULATOR	PTFE	-
GASKET	SILICONE RUBBER	-
OTHERS PARTS	STAINLESS STEEL	PASSIVATED .
-	-	-
-	-	-

Issue : 0545 B

In the effort to improve our products, we reserve the right to make changes judged to be necessary.



RADIALL®

STRAIGHT PLUG CRIMP TYPE

R125.072.081

CABLE 2.6/50 D

Series : SMA

PACKAGING

Standard	Unit	Other
100	'W' option	Contact us

SPECIFICATION

CABLE ASSEMBLY

ELECTRICAL CHARACTERISTICS

Impedance		50 Ω
Frequency		0-12.4 GHz
VSWR	1.15 +	0.020 x F(GHz) Maxi
Insertion loss		0.06 √F(GHz) dB Maxi
RF leakage	- (60 - F(GHz) dB Maxi
Voltage rating		250 Veff Maxi
Dielectric withstanding voltage		750 Veff mini
Insulation resistance		5000 MΩ mini

Stripping	a	b	c	d	e	f
mm	2.00	7.00	9.00	0.00	7.00	0.00

Assembly instruction : **Crimp 01**

Recommended cable(s)
RD 316
K02252D
SHF 316 D

Cable retention
- pull off **110** N mini
- torque **NA** N.cm

MECHANICAL CHARACTERISTICS

Center contact retention		
Axial force – Mating end	NA	N mini
Axial force – Opposite end	27	N mini
Torque	NA	N.cm mini

TOOLING

Part Number	Description	Hexagon
R282.235.037	CRIMPING DIES	3.84
R282.271.000	CRIMPING TOOL	3.84
R282.293.000	CRIMPING TOOL	-

Recommended torque		
Mating	100	N.cm
Panel nut	NA	N.cm
Clamp nut	NA	N.cm
A/F clamp nut	0.000	mm

Mating life	500	Cycles mini
Weight	3.061	g

OTHERS CHARACTERISTICS

ENVIRONMENTAL

Operating temperature	-65/+165	°C
Hermetic seal	NA	Atm.cm3/s
Panel leakage	NA	

Issue : 0545 B

In the effort to improve our products, we reserve the right to make changes judged to be necessary.

