

CMS10P10D-HF

P-Channel
RoHS Device
Halogen Free

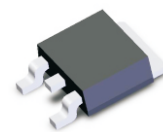

Features

- Low reverse transfer capacitance.
- Improved dv/dt capability.
- 100% EAS guaranteed.
- High switching speed.
- Low gate charge.
- Green device available.

Mechanical data

- Case: D-PAK/TO-252 standard package, molded plastic.

Circuit Diagram

- G : Gate
- S : Source
- D : Drain

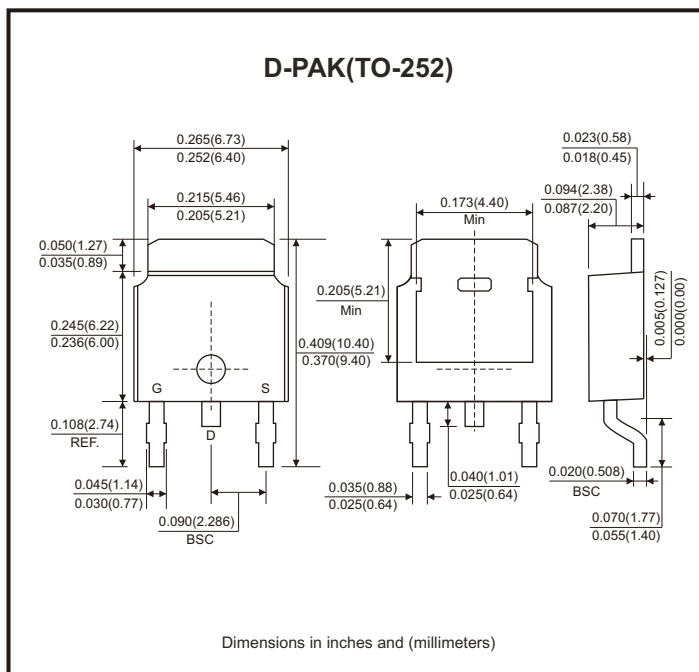
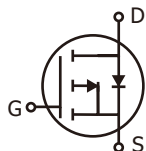

Maximum Ratings

Parameter	Conditions	Symbol	Value	Unit
Drain-source voltage		V_{DS}	-100	V
Gate-source voltage		V_{GS}	± 20	V
Continuous drain current (Note 1)	$T_C = 25^\circ\text{C}$	I_D	-10	A
	$T_C = 100^\circ\text{C}$	I_D	-6	
Pulsed drain current (Note 1, 2)	$T_C = 25^\circ\text{C}$	I_{DM}	-40	A
Total power dissipation (Note 4)	$T_C = 25^\circ\text{C}$	P_D	54	W
	$T_A = 25^\circ\text{C}$	P_D	2	
Single pulse avalanche energy, L=0.1mH (Note 3)		E_{AS}	26.4	mJ
Single pulse avalanche current, L=0.1mH (Note 3)		I_{AS}	-23	A
Operating junction and storage temperature range		T_J, T_{STG}	-55 to +150	$^\circ\text{C}$
Thermal resistance junction-ambient (Note 1)	Steady state	$R_{\theta JA}$	62.5	$^\circ\text{C/W}$
Thermal resistance junction-case (Note 1)	Steady state	$R_{\theta JC}$	2.3	$^\circ\text{C/W}$

Electrical Characteristics (at $T_j=25^\circ\text{C}$ unless otherwise noted)

Parameter	Symbol	Conditions	Min	Typ	Max	Unit
Drain-source breakdown voltage	BV_{DSS}	$V_{GS} = 0, I_D = -250\mu\text{A}$	-100			V
Gate threshold voltage	$V_{GS(th)}$	$V_{DS} = V_{GS}, I_D = -250\mu\text{A}$	-1.0	-1.9	-3.0	
Gate-source leakage current	I_{GSS}	$V_{GS} = \pm 20\text{V}$			± 100	nA
Drain-source leakage current	I_{DSS}	$V_{DS} = -100\text{V}, V_{GS} = 0$			-1	μA
Static drain-source on-resistance (Note 2)	$R_{DS(on)}$	$V_{GS} = -10\text{V}, I_D = -5\text{A}$		170	210	m Ω
		$V_{GS} = -4.5\text{V}, I_D = -3\text{A}$		190	230	
Total gate charge (Note 2)	Q_g	$I_D = -5\text{A}, V_{DS} = -80\text{V}, V_{GS} = -10\text{V}$		20		nC
Gate-source charge	Q_{gs}			3.5		
Gate-drain ("miller") charge	Q_{gd}			4.6		
Turn-on delay time (Note 2)	$t_{d(on)}$	$V_{DD} = -50\text{V}, V_{GS} = -10\text{V}$ $I_D = -5\text{A}, R_G = 25\Omega$		18		nS
Rise time	t_r			8		
Turn-off delay time	$t_{d(off)}$			100		
Fall time	t_f			30		
Input capacitance	C_{iss}	$V_{GS} = 0\text{V}, V_{DS} = -25\text{V}, f = 1\text{MHz}$		1419		pF
Output capacitance	C_{oss}			89		
Reverse transfer capacitance	C_{rss}			45		
Source-drain diode						
Forward on voltage (Note 2)	V_{SD}	$I_S = -1\text{A}, V_{GS} = 0\text{V}$		-0.74	-1.2	V
Continuous source current (Note 1, 6)	I_S				-10	A
Guaranteed avalanche characteristics						
Single pulse avalanche energy (Note 5)	EAS	$V_{DD} = -25\text{V}, L = 0.1\text{mH}, I_{AS} = -12\text{A}$	7.2			mJ

- Notes: 1. The data tested by surface mounted on a 1 inch² FR-4 board with 2 oz copper.
 2. The data tested by pulsed, pulse width $\leq 300\mu\text{s}$, duty cycle $\leq 2\%$.
 3. The EAS data shows max. rating. The test condition is $V_{DD}=-25\text{V}, V_{GS}=-10\text{V}, L=0.1\text{mH}, I_{AS}=-23\text{A}$.
 4. The power dissipation is limited by 150°C junction temperature.
 5. The min. value is 100% EAS tested guarantee.
 6. The data is theoretically the same as I_D and I_{DM} , in real applications, should be limited by total power dissipation.

Rating and Characteristic Curves (CMS10P10D-HF)

Fig.1 - Typical Output Characteristics

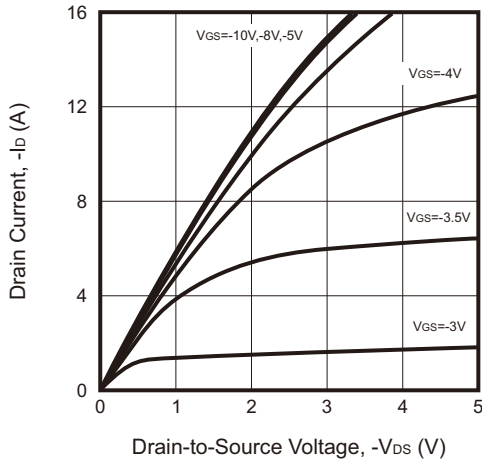

Fig.2 - Transfer Characteristics

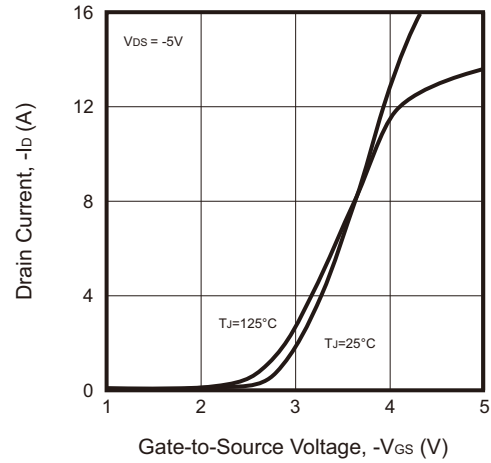

Fig.3 - On-resistance vs. Drain Current

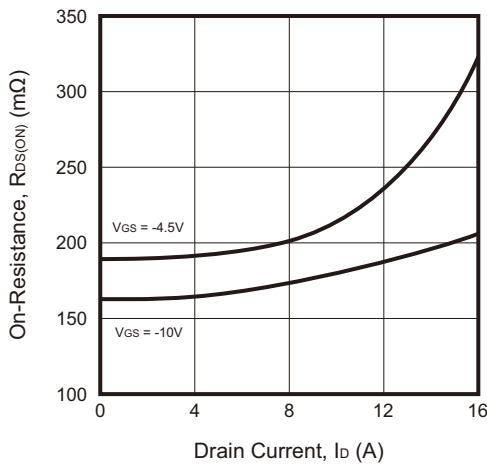

Fig.4 - Normalized $R_{DS(ON)}$ vs. T_J

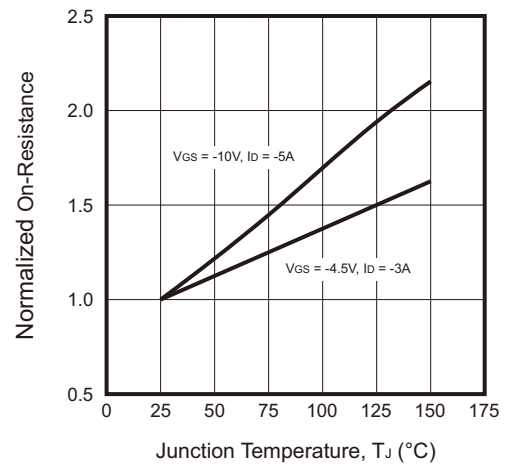

Fig.5 - On-resistance vs. G-S Voltage

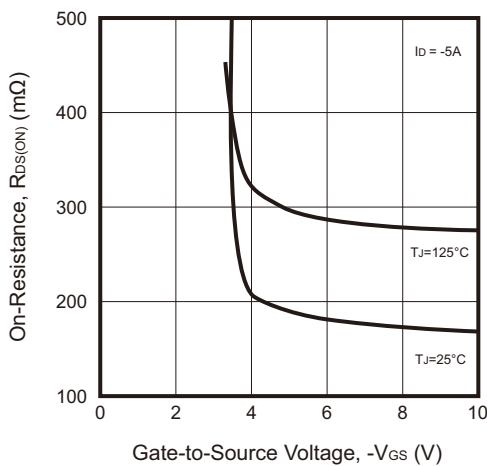
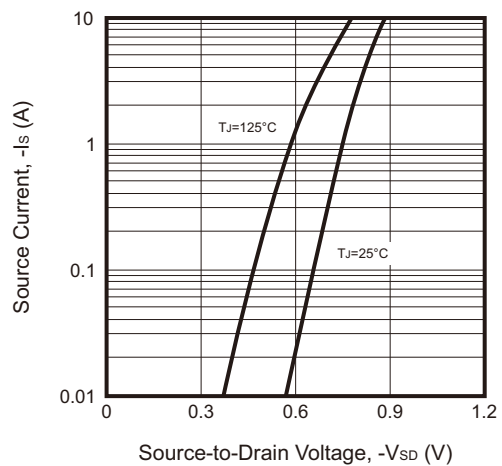

Fig.6 - Forward Characteristics of Reverse



Rating and Characteristic Curves (CMS10P10D-HF)

Fig.7 - Gate Charge Characteristics

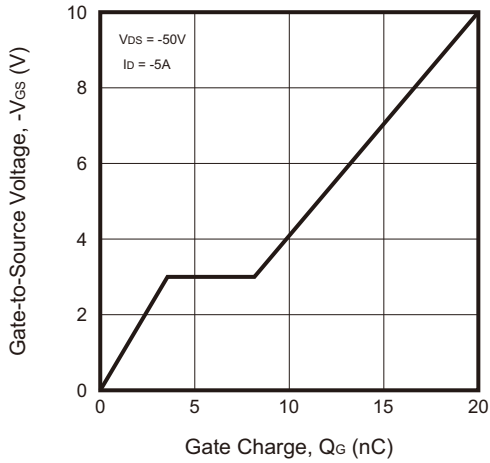

Fig.8 - Capacitance Characteristics

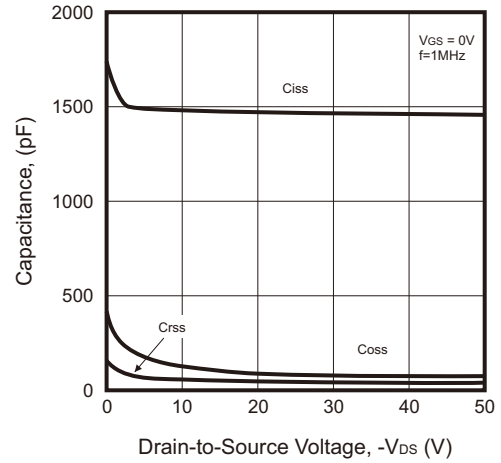

Fig.9 - Safe Operating Area

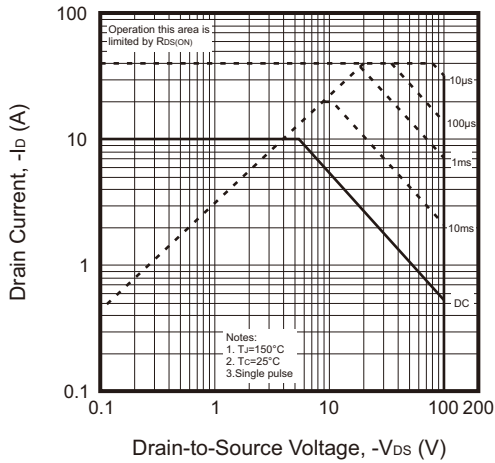
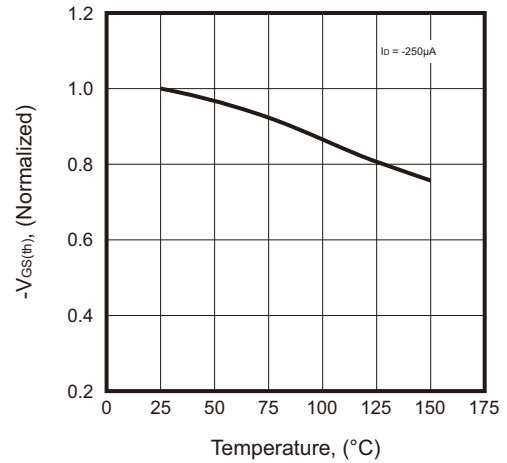
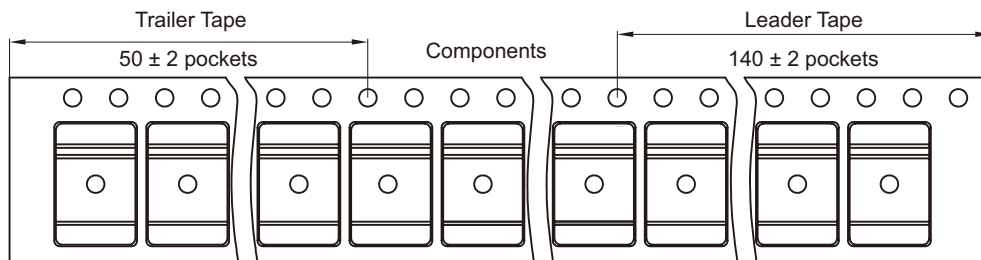
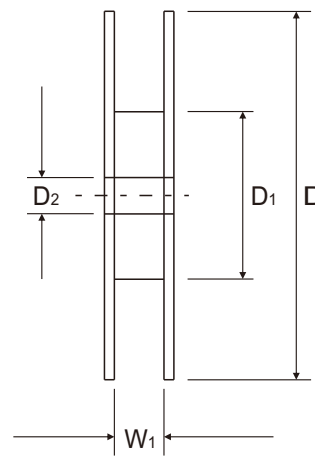
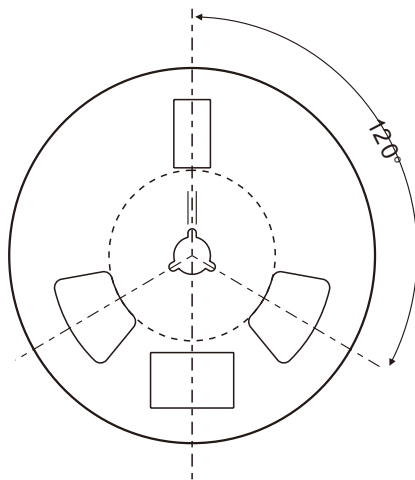
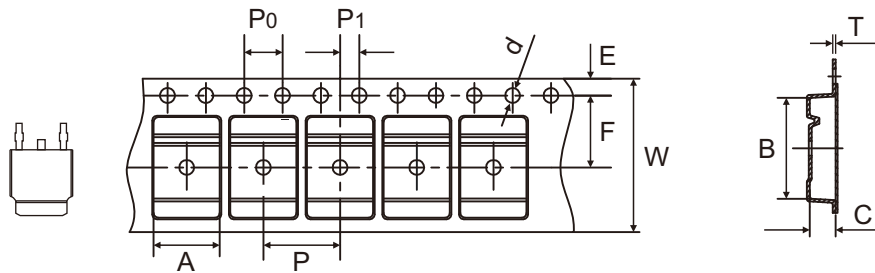

Fig.10 - Normalized $V_{GS(th)}$ vs. Temperature



Reel Taping Specification



TO-252 (D-PAK)	SYMBOL	A	B	C	d	D	D1	D2
	(mm)	6.90 ± 0.10	10.50 ± 0.10	2.78 ± 0.10	1.50 ± 0.10	330 ± 1.00	100.00 ± 0.50	13.20 ± 0.20
	(inch)	0.272 ± 0.004	0.413 ± 0.004	0.109 ± 0.004	0.059 ± 0.004	12.992 ± 0.039	3.937 ± 0.020	0.520 ± 0.008

TO-252 (D-PAK)	SYMBOL	E	F	P	P0	P1	T	W	W1
	(mm)	1.75 ± 0.10	7.50 ± 0.10	8.00 ± 0.10	4.00 ± 0.10	2.00 ± 0.10	0.25 ± 0.02	16.00 ± 0.10	16.40 ± 0.02
	(inch)	0.069 ± 0.004	0.295 ± 0.004	0.315 ± 0.004	0.157 ± 0.004	0.079 ± 0.004	0.010 ± 0.001	0.630 ± 0.004	0.646 ± 0.01

Company reserves the right to improve product design , functions and reliability without notice. REV:B

Marking Code

Part Number	Marking Code
CMS10P10D-HF	10P10A

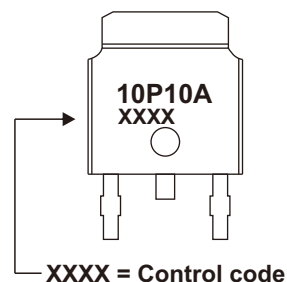

Suggested P.C.B. PAD Layout

SIZE	TO-252/D-PAK	
	(mm)	(inch)
A	6.00	0.236
B	6.50	0.256
C	3.00	0.118
D	1.40	0.055
E	6.25	0.246
F	4.60	0.181

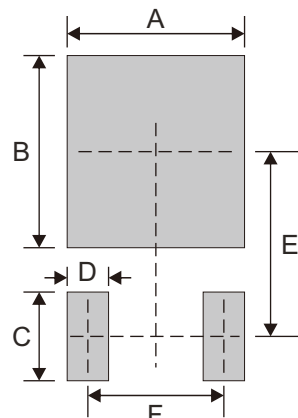

Note: 1. The pad layout is for reference purposes only.

Standard Packaging

Case Type	REEL PACK	
	REEL (pcs)	Reel Size (inch)
TO-252/D-PAK	2,500	13