

ARTICULATING MONITOR DESK MOUNT WITH SPRING ARM

For Most 13" to 27" Flat screen
Monitors and TVs

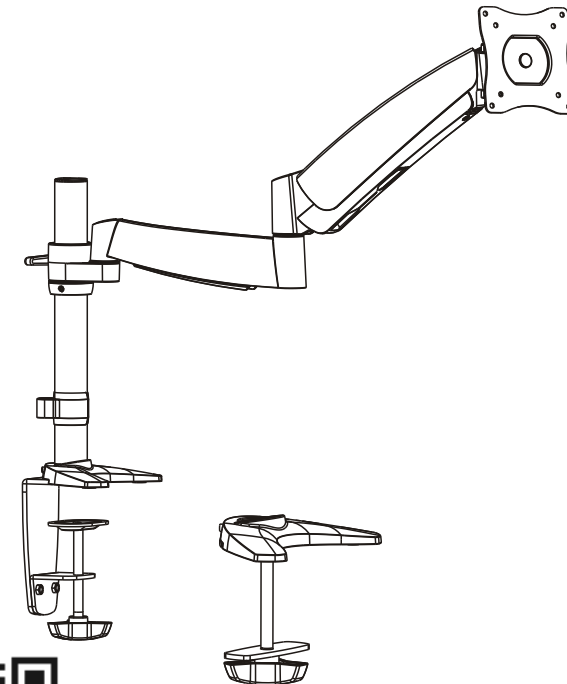

www.qualgear.com

1 Year Limited Warranty



CAUTION! Do not exceed the maximum rated weight specified below. Otherwise, serious injury or property damage may occur.

Maintenance

Please check that the desk mount is secure and safe to use at regular intervals.

If you have any questions regarding any of the instructions or warnings, please contact your local distributor directly (OR) contact QualGear technical support via email at support@qualgear.com.

QG-DM-01-023



VESA
75x75 100x100



NOTE: Read the entire installation manual before you start installation and assembly.

WARNING

- Do not begin the installation of this product before you have read and understood all the instructions and warnings contained in this installation manual. If you have any questions regarding the instructions, please contact the reseller or QualGear support department via email at support@qualgear.com.
- This mounting bracket was designed to be installed and utilised ONLY as specified in this manual. Improper installation of this product may cause damage or serious injury.
- Make sure that the supporting surface will safely support the combined weight of the equipment and all attached hardware and components.
- This product should only be installed by someone, who has good mechanical ability with prior experience in installation and assembly of products and fully understands this manual.
- Always use an assistant or mechanical lifting equipment to safely lift and position the equipment.
- Tighten screws firmly, but do not over tighten. Over tightening can cause damage to the items, This greatly reduces their holding power.
- All QUALGEAR products are intended for indoor use only and any outdoor use voids the limited warranty.
- All QUALGEAR products are designed and tested for residential use only and any commercial use voids the limited warranty. For warranty information, please visit qualgear.com/warranty.php.

Parts Checklist

IMPORTANT: Before starting installation, please check that all parts shown in this checklist are included. If any parts are missing or damaged, contact your local distributor or support@qualgear.com for replacement parts and do not start assembly and installation until you receive all the parts.

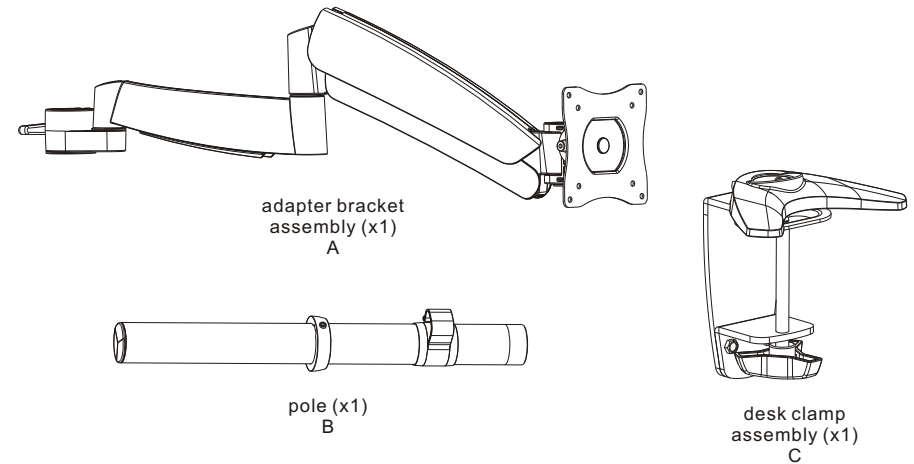

Hardware Package

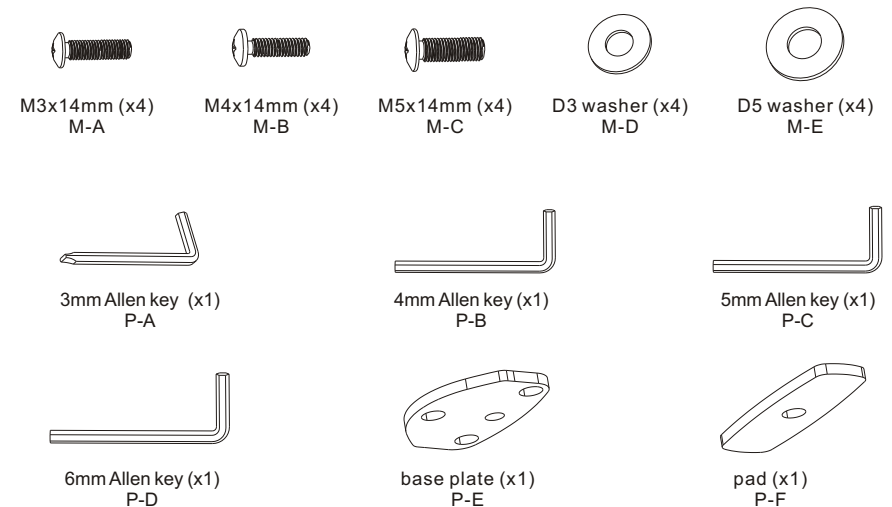

1 Installing the Pole and the Desk Clamp Assembly

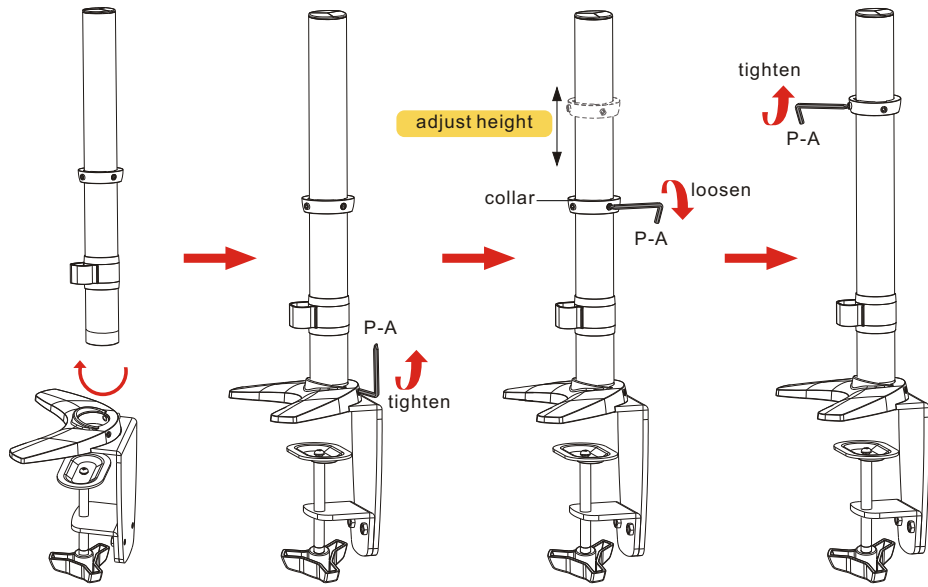

Insert the pole (B) into the desk clamp (C) and tighten the screws using 3mm Allen Key (P-A). To adjust monitor height, first loosen collar screws using 3mm Allen Key (P-A), then set the collar at a desired position and tighten the collar screws using 3mm Allen Key (P-A).

2a Edge Installation

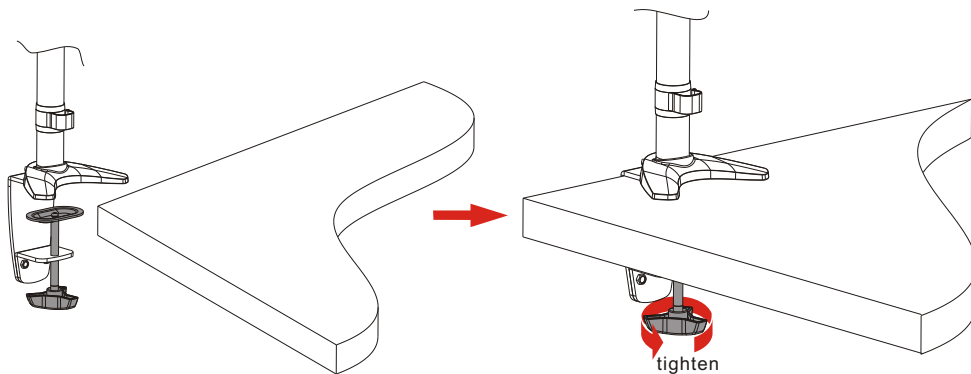

NOTE: Min. desktop thickness=10mm(0.39")
Max. desktop thickness=90mm(3.54")

- Determine the mounting location based on the display size, height adjustment and pitch/roll requirements.
- Place the desk mount over the edge of the desk so that the clamp fully contacts the desk edge.
- Turn the knob to make clamp fit to the desk edge, then secure it tightly.

2b Grommet Installation

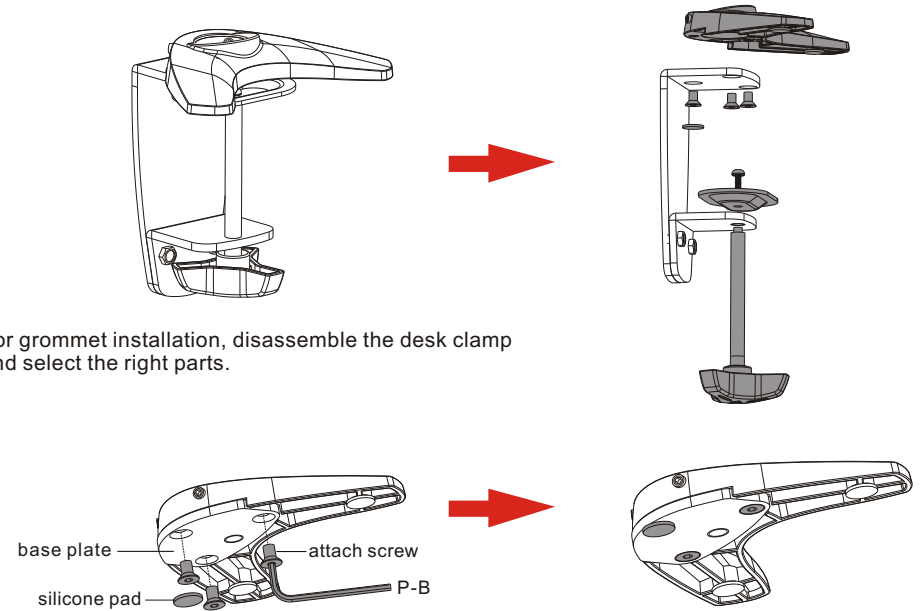

For grommet installation, disassemble the desk clamp and select the right parts.

Reinstall the base plate with the three retained screws, and then tighten securely using a 4mm Allen Key (P-B). Then attach silicone pad for each screw.

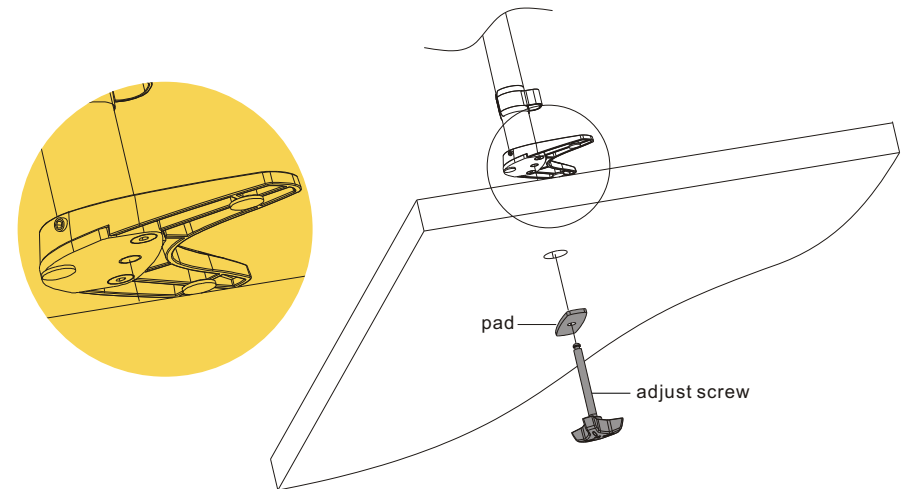

Insert the adjust screw into the base plate through the hole and pad (P-F) as shown above. Then tighten the adjust screw to hold the mount securely.

NOTE: Min. hole diameter =10mm(0.39")
Max. hole diameter =70mm(2.76")

3 Installing the Adapter Bracket

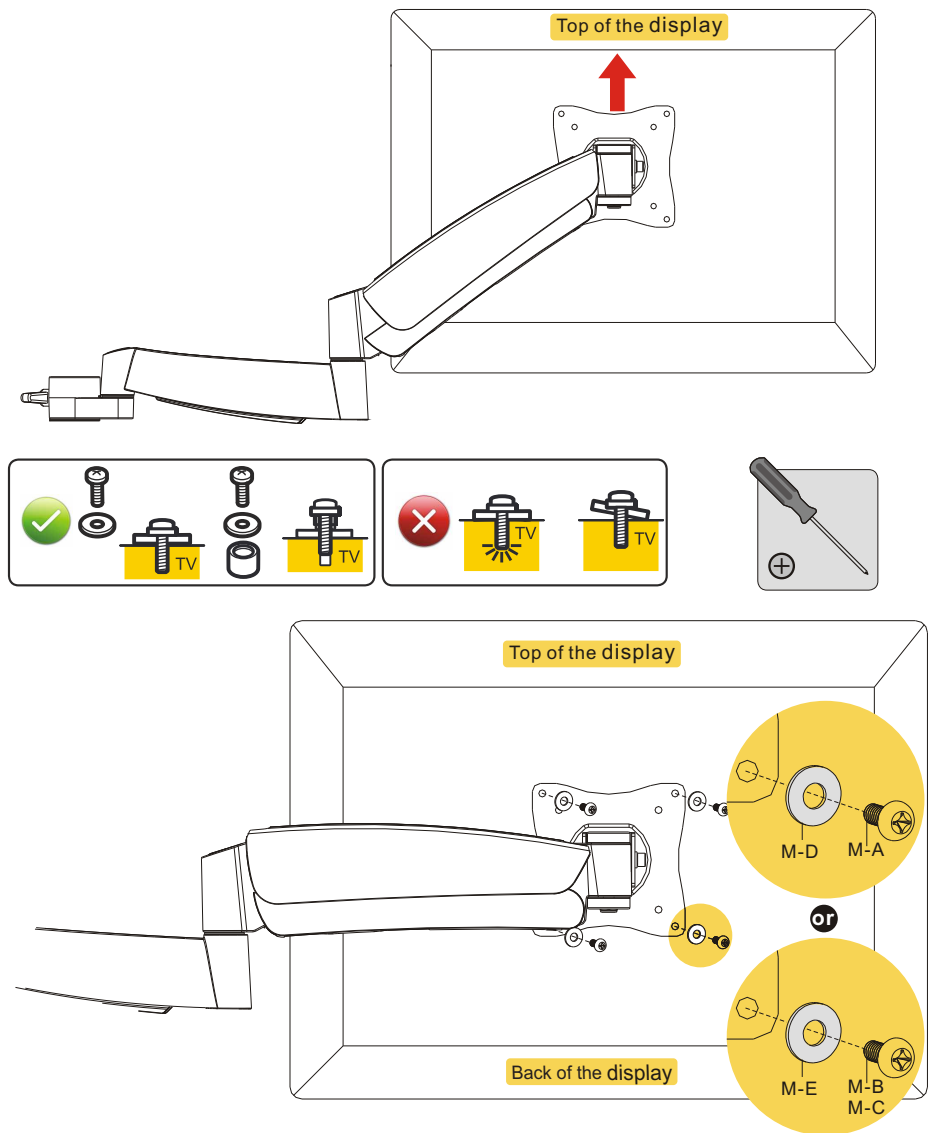

Choose appropriate screws and washers according to the type of your display, and then attach the adapter bracket assembly onto the back of the display, and tighten the screws using a Philips screwdriver.



WARNING

Tighten all screws but do not over tighten.

4 Installing the Adapter Bracket Assembly (attached display)

HEAVY!
You may need assistance with this step.

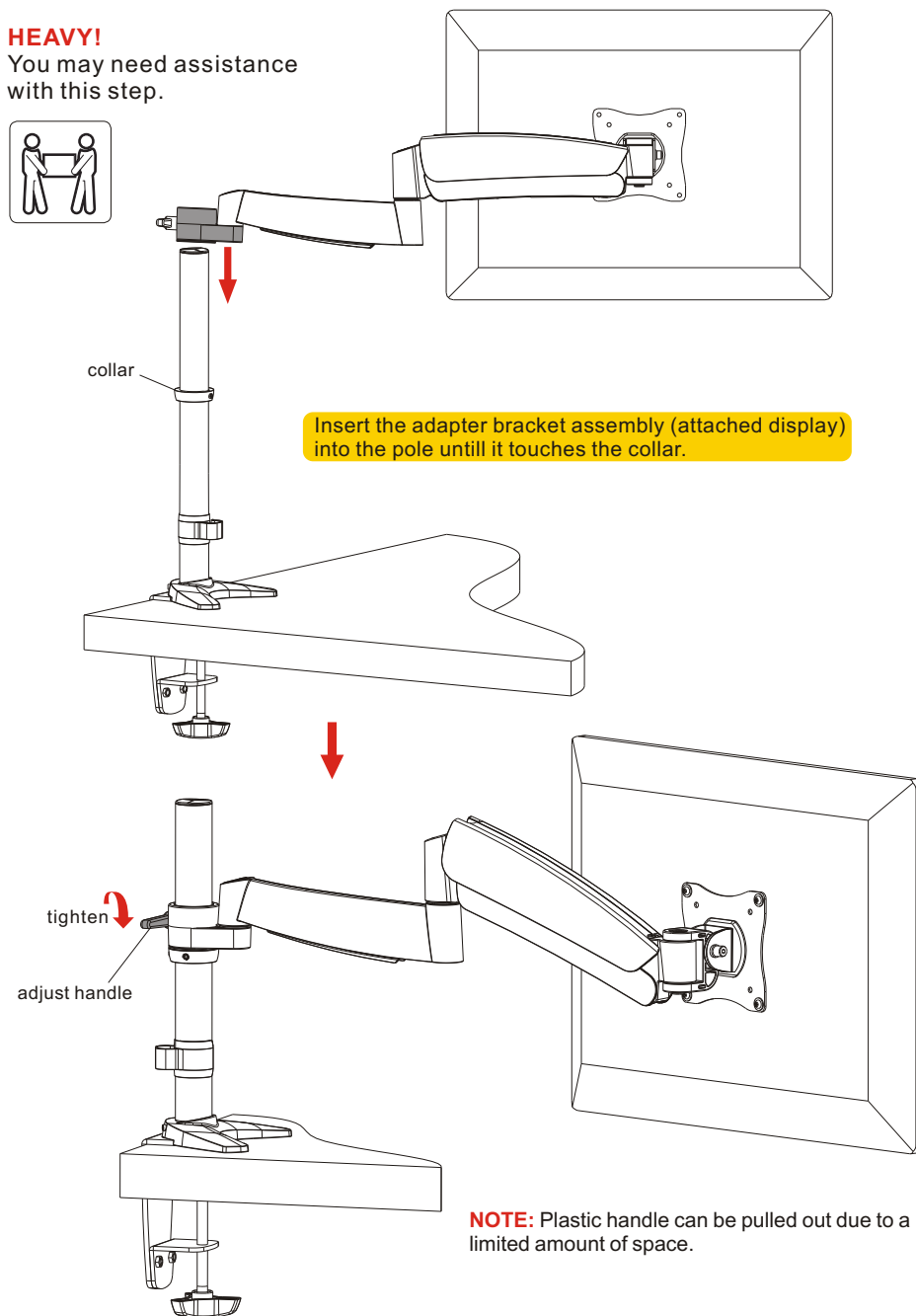

NOTE: Plastic handle can be pulled out due to a limited amount of space.

5 Tension Adjustment

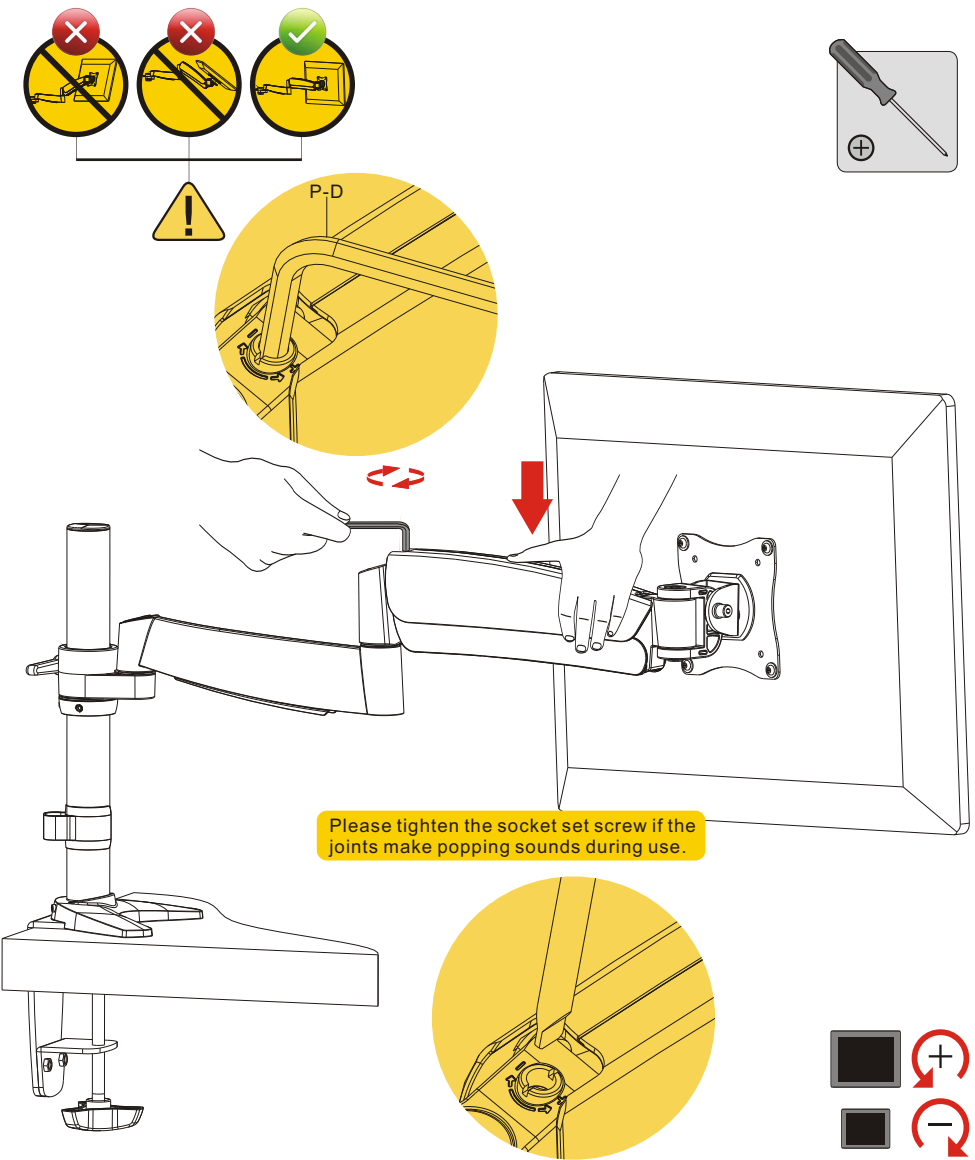

To change the factory preset tension, first apply the force with the forearm and make sure that the arm is level, then using a 6mm Allen Key (P-D), slightly loosen or tighten the adjustment screw as necessary.

If display settles on its own, then rotate the adjustment screw towards the "+" symbol. If display rises on its own, then rotate the adjustment screw towards the "-" symbol.

6 Cable Management

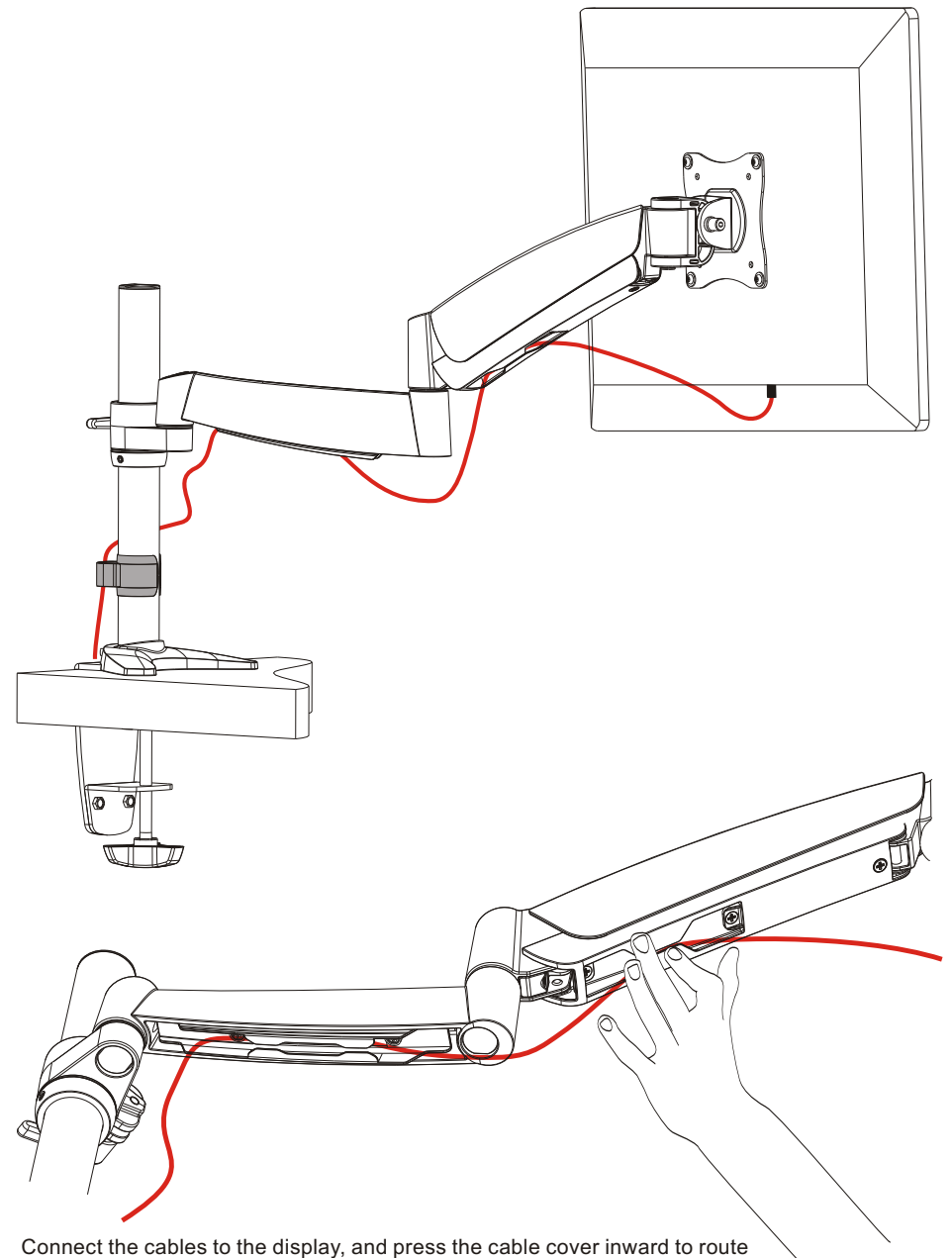

Connect the cables to the display, and press the cable cover inward to route the cables through the space.

NOTE: Leave slack in the cable for arm movement.

7 Adjustments

