

- Note:
- The Cable Assembly should meet RoHS2.0 Compliant.
 - Electrical and Mechanical Performance should meet SAS 4.0 specifications.
 - The Cable Assembly should meet below impedance requirement: $85 \pm 15\% \Omega$ for Termination Area and Cable Absolute Area.

REVISION			
REV	DESCRIPTION	DATE	APPROVED
A	Initial Release	1/11/2022	Lemon

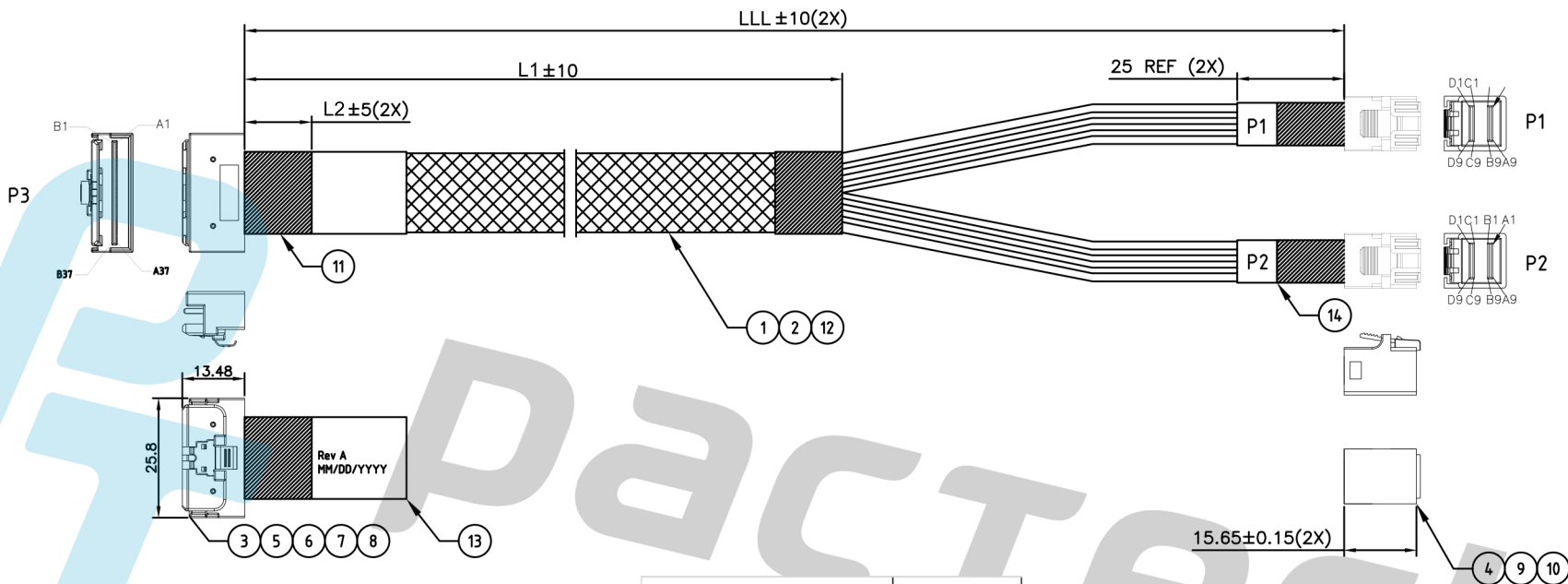

Part Number	Length (mm)
PT-SAS-SL8LP-43RAX2-025	250
PT-SAS-SL8LP-43RAX2-050	500
PT-SAS-SL8LP-43RAX2-075	750
PT-SAS-SL8LP-43RAX2-100	1000

TEST CONDITIONS:

- 100% OPEN & SHORT & MISS-WIRING & INTERMITTENCE TEST.
- CONDUCTIVE RESISTANCE: 3Ω MAX.
- INSULATION RESISTANCE: $10 M\Omega$
- HI-POT TEST: 300VDC FOR 10ms.
- THIS PRODUCT MEETS PCIe4.0.

APPROVED BY _____
 COMPANY: _____
 PURCHASING/ENGINEER: _____
 DATE: _____

14	LABEL	2	WHITE LABEL, 50*10MM(REF)
13	LABEL	1	WHITE LABEL, 60*30MM(REF)
12	WEAVE	A/R	PLASTIC BRAID SLEEVE, PET, GREEN, OD:10.0MM
11	ACETATE TAPE	A/R	ACETATE TAPE, W=25MM, BLACK
10	HOUSING	2	HOUSING FOR SFF-8643 4i STR, BLACK
9	INNER MOLD	2	INNER MOLDING FOR SFF-8643 4i STR, BLACK
8	RIVET	2	RIVET FOR SFF-8654
7	LATCH	1	LATCH FOR SFF-8654
6	HOUSING	1	HOUSING FOR LP SFF-8654 8i STR, BLACK
5	INNER MOLD	1	INNER MOLDING FOR SFF-8654 8i STR, BLACK
4	8643 4i PCB	4	PCB FOR INT. MINI SAS HD 4i STR, AU30u", 85 ohm
3	LP 8i PCB	1	PCB FOR LP SLIMLINE SAS 8i STR, AU30u", 85 ohm
2	WIRE	A/R	UL1571, 32AWG
1	SAS CABLE	A/R	SAS CABLE: UL20744 32AWG 85ohm, PCIE 4.0

THIS DOCUMENT CONTAINS PROPRIETARY INFORMATION WHICH SHALL NOT BE REPRODUCED, TRANSFERRED, TO OTHER DOCUMENTS, DISCLOSED OR USED FOR ANY OTHER PURPOSE WITHOUT PRIOR WRITTEN PERMISSION OF PACTECH



DESCRIPTION
 500mm SlimSAS LP SFF-8654 8i Straight to Dual MiniSAS HD SFF-8643 4i Straight PCIe 4.0 85u Cables

CUSTOMER PART NUMBER

DRAWN BY
Man Hin Wong

CHECKED BY
A. Liu

SIZE
A

PART NUMBER
PT-SAS-SL8LP-43RAX2-LLL

REV
A

APPROVED BY
A. Chui

UNIT
Milimeter

SCALE

SHEET
Page 1/1

Name QTY Description

		REVISION	DATE	APPROVED
REV		DESCRIPTION		
A		Initial Release	1/11/2022	Lemon

Wire Table

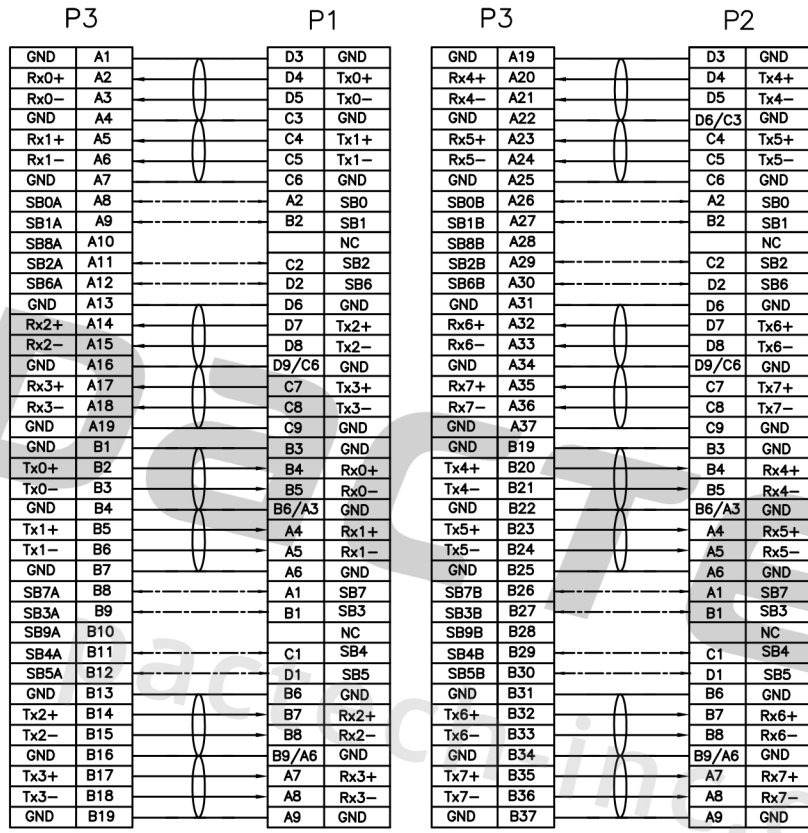

- TEST CONDITIONS:
- 100% OPEN & SHORT & MISS-WIRING & INTERMITTENCE TEST.
 - CONDUCTIVE RESISTANCE: 3Ω MAX.
 - INSULATION RESISTANCE: 10 MΩ
 - HI-POT TEST: 300VDC FOR 10ms.
 - THIS PRODUCT MEETS PCIe4.0.

APPROVED BY _____
 COMPANY: _____
 PURCHASING/ENGINEER: _____
 DATE: _____

14	LABEL	2	WHITE LABEL, 50*10MM(REF)
13	LABEL	1	WHITE LABEL, 60*30MM(REF)
12	WEAVE	A/R	PLASTIC BRAID SLEEVE, PET, GREEN,OD:10.0MM
11	ACETATE TAPE	A/R	ACETATE TAPE, W=25MM, BLACK
10	HOUSING	2	HOUSING FOR SFF-8643 4i STR, BLACK
9	INNER MOLD	2	INNER MOLDING FOR SFF-8643 4i STR, BLACK
8	RIVET	2	RIVET FOR SFF-8654
7	LATCH	1	LATCH FOR SFF-8654
6	HOUSING	1	HOUSING FOR LP SFF-8654 8i STR, BLACK
5	INNER MOLD	1	INNER MOLDING FOR SFF-8654 8i STR, BLACK
4	8643 4i PCB	4	PCB FOR INT. MINI SAS HD 4i STR, AU30u",85 ohm
3	LP 8i PCB	1	PCB FOR LP SLIMLINE SAS 8i STR, AU30u",85 ohm
2	WIRE	A/R	UL1571, 32AWG
1	SAS CABLE	A/R	SAS CABLE: UL20744 32AWG 85ohm, PCIE 4.0
	Name	QTY	Description

THIS DOCUMENT CONTAINS PROPRIETARY INFORMATION WHICH SHALL NOT BE REPRODUCED, TRANSFERRED, TO OTHER DOCUMENTS, DISCLOSED OR USED FOR ANY OTHER PURPOSE WITHOUT PRIOR WRITTEN PERMISSION OF PACTECH



DESCRIPTION
 500mm SlimSAS LP SFF-8654 8i Straight to Dual MiniSAS HD SFF-8643 4i Straight PCIe 4.0 85u Cables

CUSTOMER PART NUMBER

DRAWN BY Man Hin Wong	CHECKED BY A. Liu	SIZE A	PART NUMBER PT-SAS-SL8LP-43RAX2-LLL	REV A
APPROVED BY A. Chui	UNIT Milimeter	SCALE	SHEET Page 1/1	