



3.17"W x 5.5"L x 1.6"H

- 150 Watts Output Power
- Single and Dual Outputs
- Universal 90-264VAC Input
- 5VDC to 48VDC Outputs
- 5656VDC Input to Output Isolation
- Active Power Factor Correction



Model Number	Output Voltage	Output Amps (max)	Line Regulation (max)	Ripple & Noise
<b>SINGLE OUTPUT</b>				
PMMK150S-5E	5 VDC	30	±1%	150mV pk-pk
PMMK150S-12E	12 VDC	12.5	±1%	150mV pk-pk
PMMK150S-15E	15 VDC	10	±1%	150mV pk-pk
PMMK150S-24E	24 VDC	6.3	±1%	150mV pk-pk
PMMK150S-48E	48 VDC	3.2	±1%	250mV pk-pk
<b>DUAL OUTPUT</b>				
PMMK150D-AE	5/12 VDC	15/7	±0.5/1%	50/100mV pk-pk
PMMK150D-BE	5/24 VDC	15/3.5	±0.5/2%	50/200mV pk-pk
PMMK150D-CE	12/24 VDC	7/3.5	±1/2%	100/200mV pk-pk
PMMK150D-DE	12/48 VDC	7/1.5	±1/4%	100/400mV pk-pk

Medical Grade 150 Watt Enclosed with PFC

**PMMK150E** series

**INPUT SPECIFICATIONS**

Input Voltage Range	90-264 VAC (100-240VAC nom.)
Frequency Range	47-63 Hz
Power Factor Correction	0.96 min. at nom. Input
Inrush Current, typ at cold start:	30A @ 115VAC
	60A @ 230VAC *
Leakage Current	<0.3mA @ 264VAC, 50Hz

**OUTPUT SPECIFICATIONS**

Voltage and Current (Note 6)	See Selection Chart
Line Regulation (Note 8)	See Selection Chart
Load Regulation (20%-FL)	Singles: $\pm 1\%$ , max.
Cross Regulation (note 7)	Duals: $\pm 3/5\%$
Preset Accuracy (Note 9)	$\pm 1\%$ , typ
Ripple/Noise (Notes 1, 3, 10)	See Selection Chart
Over Voltage Protection	130% max. of nom. input
	Auto Recover after fault condition is removed *
Over Current Protection	150% max. of FL at nom. input
Short Circuit Protection	Auto Recover after fault condition is removed *
Hold Up Time	20mS, typ (Nom I/P, FL)

**GENERAL SPECIFICATIONS**

Isolation (Note 4)	I/P-O/P: 5656VDC	
	I/P-Ground: 2828VDC	
	O/P-Ground: 707VDC	
Efficiency	75%, min. at nom. input	
Safety UL/cUL:	ANSI/AAMI ES60601-1 3rd ed.	
	CSA C22.2 No. 60601-1 3rd ed.	
	CB:	IEC60601-1 3rd ed.
	CE:	EN60601-1-2

All specifications are typical at nominal input, full load, and 25°C unless otherwise noted

\* These are stress ratings. Exposure of the devices to any of these conditions may adversely affect long term reliability. Proper operation under conditions other than the standard operating conditions is neither warranted nor implied.

**ENVIRONMENTAL SPECIFICATIONS**

Oper. Temperature	-10 to +70°C
	(See Derate Curve)
Storage Temperature	-25 to +85°C *
Relative Humidity	0% to +95%, non-cond *
EMC	EN55011 Class B
MTBF	270,000 Hrs
	Mil Std 217, 25°C

**PHYSICAL SPECIFICATIONS**

Size	3.17" x 5.5" x 1.6"
Construction	Enclosed
Weight	1.3 lb, (590g)

**NOTES**

1. All measurements should be made directly at the terminals of the power supply
2. All specifications typical @ 25°C, unless otherwise noted, at nominal line and load.
3. Ripple and noise dependent upon output voltage as specified per particular model.
4. Isolation for up to 1 minute duration.
5. Specified for free air convection cooling.
6. Minimum load is not required for proper operation.
7. Load Regulation is measured by change  $\pm 40\%$  of measured output load from 60% full load, with the other output set to 60% full load.
8. Line Regulation measured from 90-264VAC. 100VAC minimum required for full load start.
9. Preset Accuracy measured at nominal load, 120VAC input.
10. O/P Noise measured directly at the pins/terminals at nominal load, 0.1uF bypass and 47uF electrolytic, pk-pk @ 20MHz bandwidth.

**MECHANICAL DIMENSIONS - SINGLE OUTPUT**

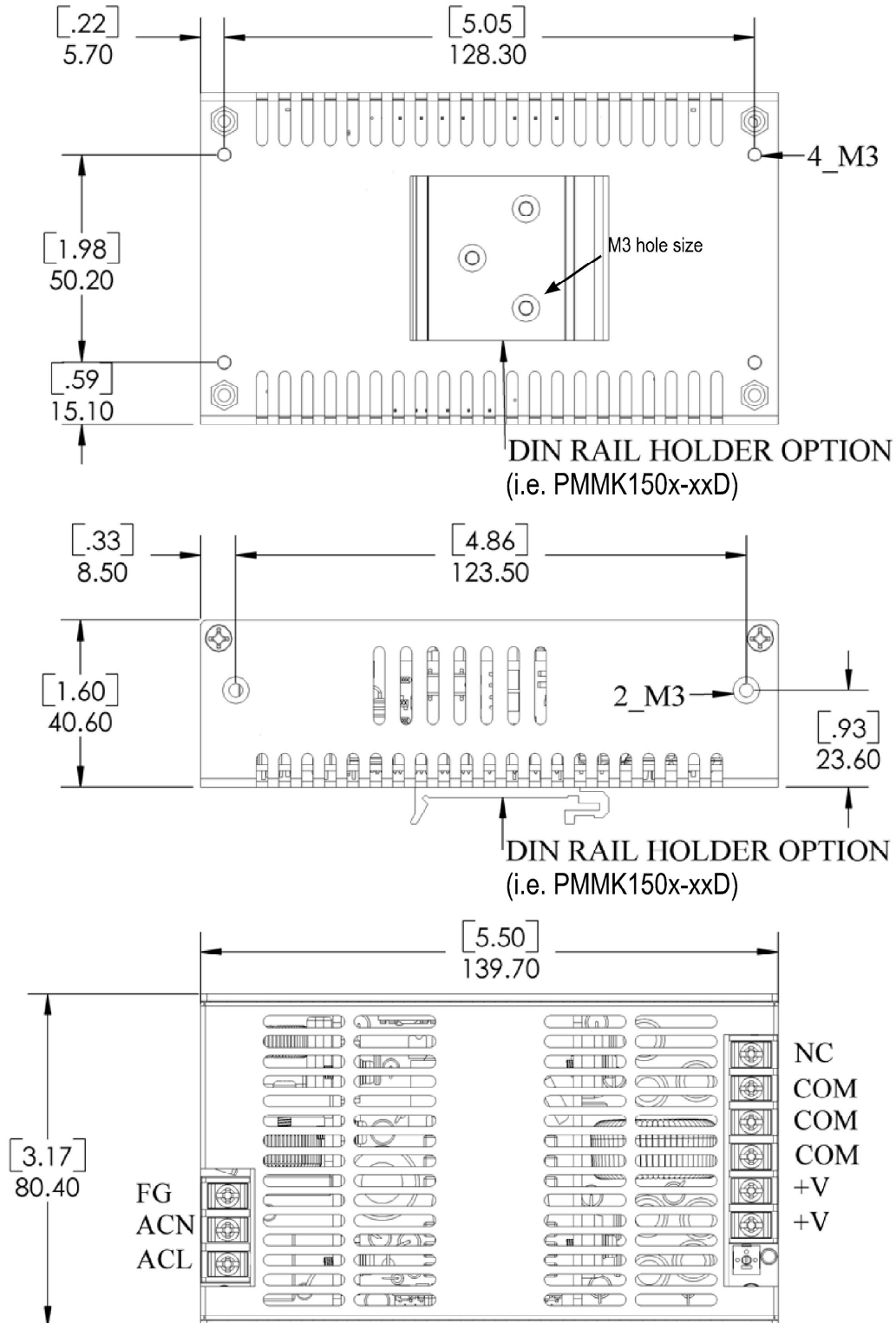

**MECHANICAL DIMENSIONS - DUAL OUTPUT**

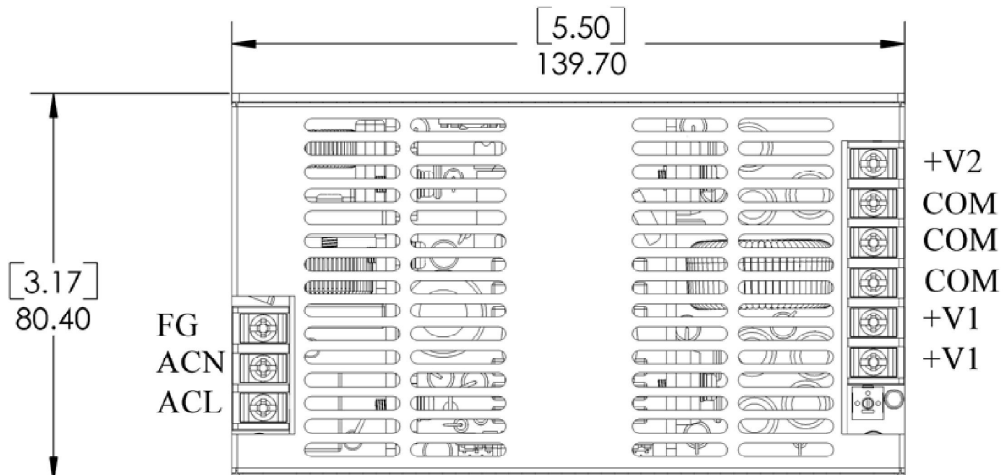
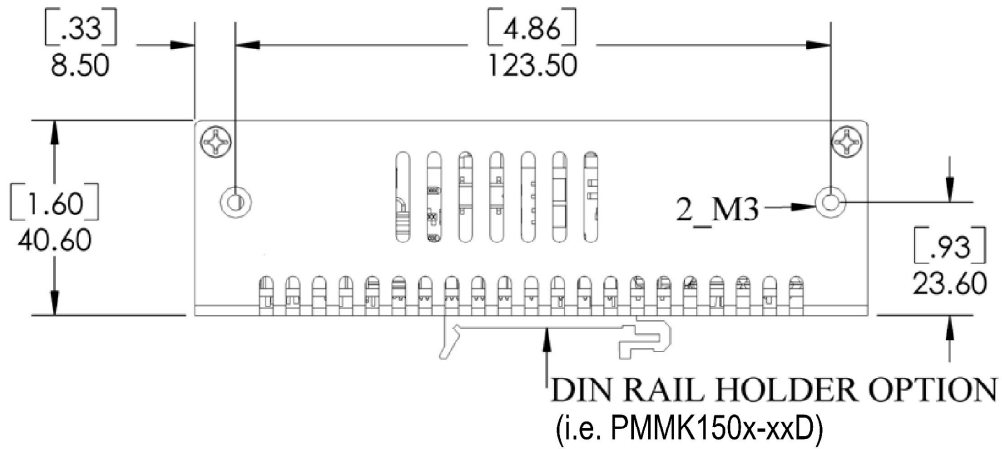
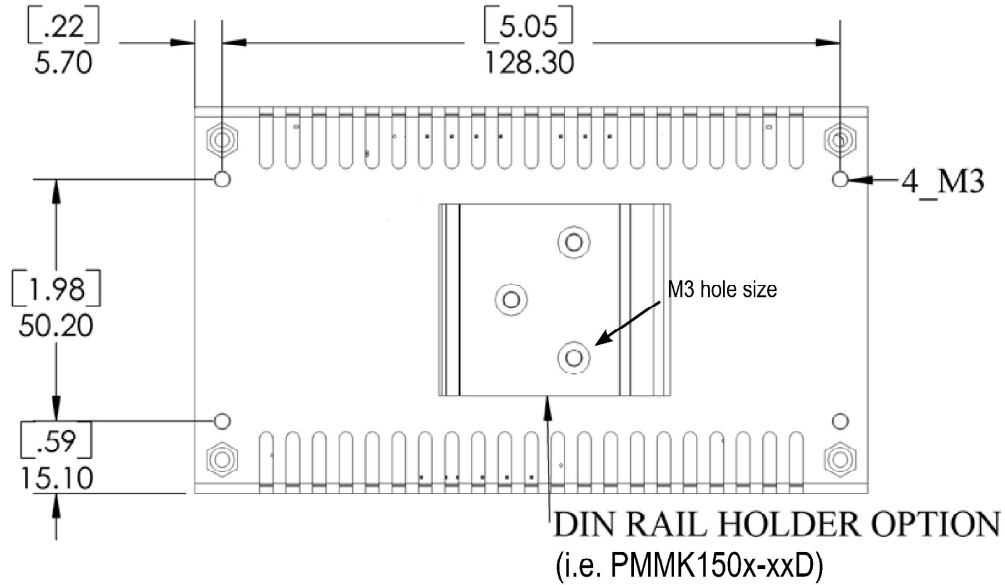

**OUTPUT DERATING CURVE - SINGLE OUTPUT**

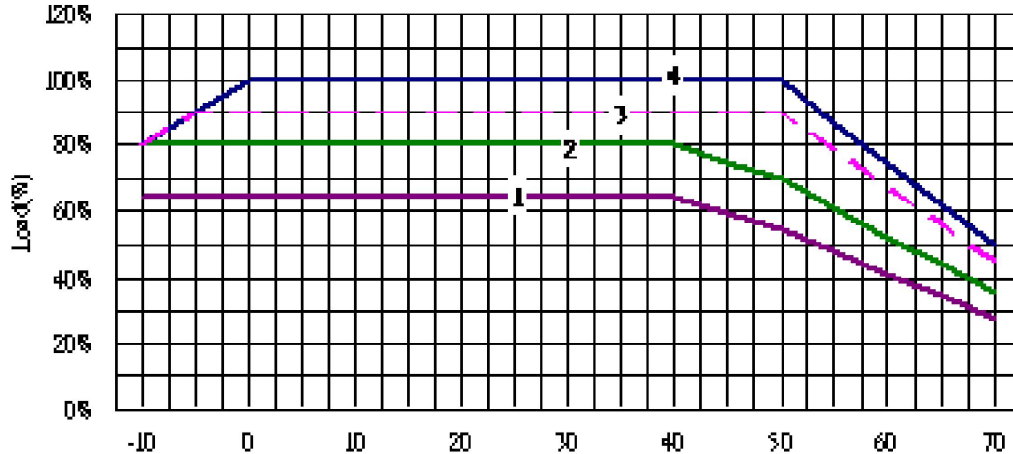

1. 5V convection
2. 12V, 15V, 24V, 48V convection
3. 5V Forced air cooling 10CFM
4. 12V, 15V, 24V, 48V Forced air cooling 10CFM

**OUTPUT DERATING CURVE - DUAL OUTPUT**

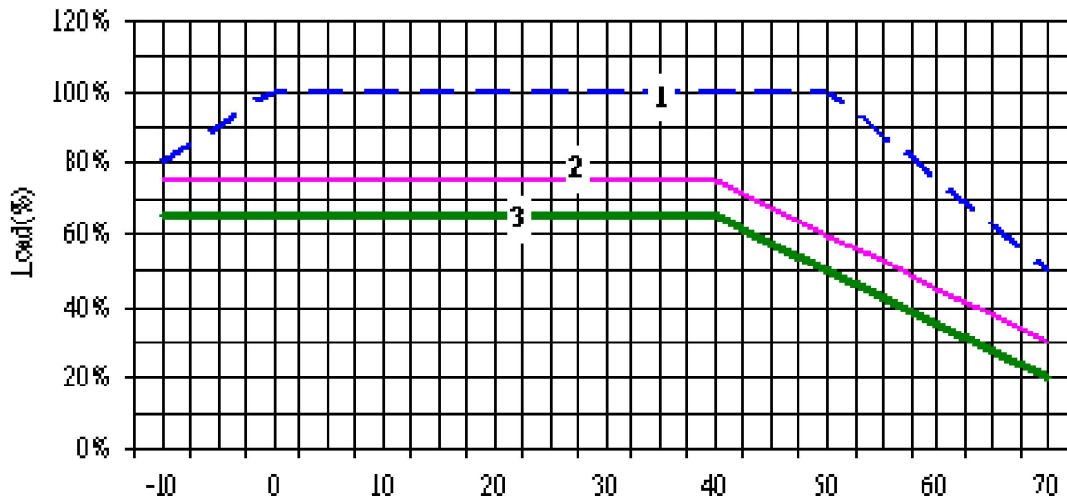

1. Forced air colling 10 CFM
2. Free air convection
  - Open Frame, U-Channel
3. Free air convection
  - Enclosed