

THIS DRAWING IS SUPPLIED FOR INFORMATION ONLY. DESIGN FEATURES, SPECIFICATIONS AND PERFORMANCE DATA SHOWN HEREON ARE THE PROPERTY OF THE AMPHENOL CORPORATION. NO RIGHTS OF REPRODUCTION ARE IMPLIED. ALL DIMENSIONS ARE SUBJECT TO NORMAL MANUFACTURING VARIATIONS.

CUSTOMER DRAWING

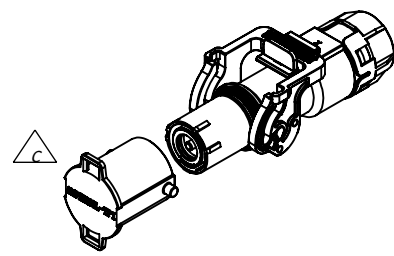
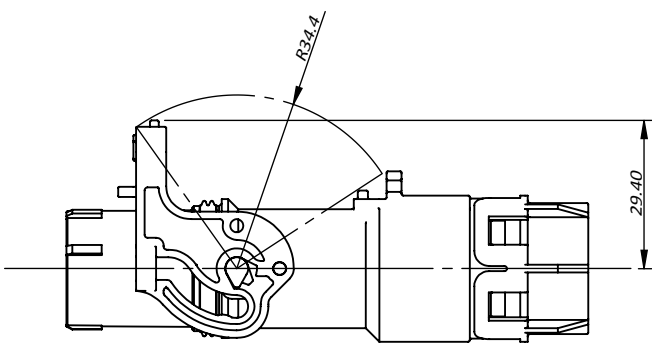
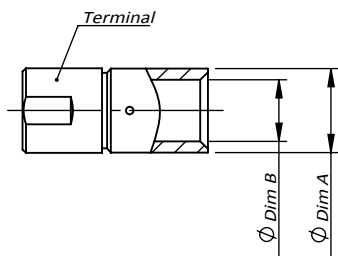
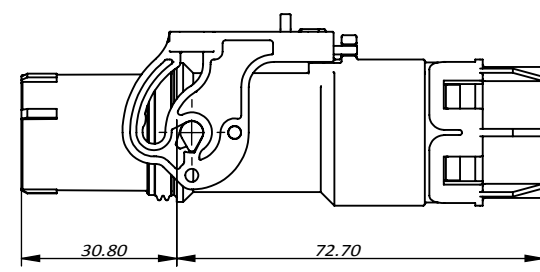
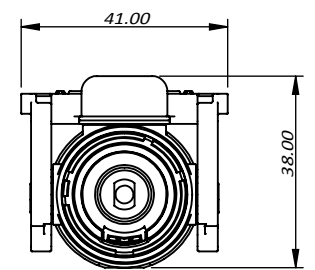

REVISIONS					
REV#	ECN#	REVISION ACTION	REV.BY:	APPR.BY:	DATE
A	--	INITIAL RELEASE	JX	JL	03/09/2020
B	--	增加表格信息	Star	James	10/29/2020
C	--	Add Package specification P/N And Add Dust Cap Protection Cap	Star	JL	03/04/2021

订购信息 Ordering Information

PL18 X - 30 1 - 70 - 2 - 5

Key and Color	HVIL	Cable Size	Cable Type:
"X", Orange	"0", NO HVIL	"50"=50mm ²	"-5", Huber+Suhner
"Y", Black	"1", With HVIL	"70"=70mm ²	
"U", Yellow			
"V", Green			
"W", Red			
"T", Blue			

规格参数(Spec.):

- 工作温度 Operating temperature: -40°C ~ +125°C.
- 带高压互锁 Electrical interlock (HVIL).
- 额定电流 Current rating:
Power: 50mm², 200A; 70mm², 250A; HVIL: 5A.
- 额定电压 Operating voltage:
Power: 1000 VDC; Signal: 60 VDC.
- 耐电压 Dielectric withstanding voltage:
 - A. 与插座对插后, Pin与铁壳之间
When mated, between pin and metal shell: 5000 VDC.
 - B. 与插座对插后, Pin与HVIL之间
When mated, between pin and HVIL: 5000 VDC.
 - C. 与插座对插后, HVIL与铁壳之间
When mated, between HVIL and metal shell: 500 VDC.
 - D. 与插座对插前, 两个HVIL端子之间耐压
Before mating, between two HVIL terminals: 500 VDC.
- 防护等级 Protection class: Mated-IP6k9k & IP67, unmated-IP2X.
- 电磁屏蔽 360° full Shielding.
- 机械寿命 Mating cycle: 100 Min.
- 带CPA的摇杆系统 Latch system with CPA.
- 绝缘材料满足UL94 V-0 Inner insulation material satisfy UL94V-0.
- 镀锌/锌镍合金, 符合RoHS, 满足500H中性盐雾实验
Gray Zinc/Nickel(ZnNi) Plating. RoHS compliant, Rated at 500hours salt spray.

Standard Part List:

Model No.	H+S Part No.	Dia. Primary Insulation(mm)	Dia. of Screen max. (mm)	Overall-Dia. Nominal(mm)	Outside-Dia. of terminal(mm): "A"	Inside-Dia. of terminal(mm): "B"
PL18(X)-30X-70-2-5	84100298	13.7±0.3	14.6	17.0±0.3	16.7±0.3	12.2±0.3
PL18(X)-30X-50-2-5	84096257	11.5±0.3	12.6	14.9±0.3	14.0±0.3	10.0±0.3

	Amphenol Technical Products International Asia.					PART NAME: PL300 G2 1POS Straight Plug
	第三角投影 THIRD ANGLE PROJECTION	页面 SHEET	幅面 SIZE	版次 REV.	比例 SCALE	
签名 SIGNATURE		日期 DATE		UNLESS OTHERWISE SPECIFIED 1) All dimensions are in metric(mm). 2) Tolerances are as follows:		
制图 DRAWN		Star		03/04/2021		
审核 CHECKED				1.PL DEC ± 1.00 2.PL DEC ± 0.50 3.PL DEC ± 0.20		
批准 APPROVAL				Angles ±1°		
				CUST PART #		
				CUST REV.		

THIS DRAWING IS SUPPLIED FOR INFORMATION ONLY. DESIGN FEATURES, SPECIFICATIONS AND PERFORMANCE DATA SHOWN HEREON ARE THE PROPERTY OF THE AMPHENOL CORPORATION. NO RIGHTS OF REPRODUCTION ARE IMPLIED. ALL DIMENSIONS ARE SUBJECT TO NORMAL MANUFACTURING VARIATIONS.

1	2	3	4	5	6	7	8
型号 Model	Kit Package P/N	Bulk Package P/N			REVISIONS		
PL18X-300-50-2-5	AC-HA010794	AC-HA010794-2			REV#	ECN#	REVISION ACTION
PL18Y-300-50-2-5	AC-HA010795	AC-HA010795-2			A	--	INITIAL RELEASE
PL18U-300-50-2-5	AC-HA010796	AC-HA010796-2			B	--	增加表格信息
PL18V-300-50-2-5	AC-HA010797	AC-HA010797-2			C	--	Add Package specification P/N And Add Dust Cap Protection Cap
PL18W-300-50-2-5	AC-HA010798	AC-HA010798-2					REV.BY: APPR.BY: DATE
PL18T-300-50-2-5	AC-HA010799	AC-HA010799-2					JX JL 03/09/2020
PL18X-300-70-2-5	AC-HA010800	AC-HA010800-2					Star James 10/29/2020
PL18Y-300-70-2-5	AC-HA010801	AC-HA010801-2					Star JL 03/04/2021
PL18U-300-70-2-5	AC-HA010802	AC-HA010802-2					
PL18V-300-70-2-5	AC-HA010803	AC-HA010803-2					
PL18W-300-70-2-5	AC-HA010804	AC-HA010804-2					
PL18T-300-70-2-5	AC-HA010805	AC-HA010805-2					
PL18X-301-50-2-5	AC-HA010818	AC-HA010818-2					
PL18Y-301-50-2-5	AC-HA010819	AC-HA010819-2					
PL18U-301-50-2-5	AC-HA010820	AC-HA010820-2					
PL18V-301-50-2-5	AC-HA010821	AC-HA010821-2					
PL18W-301-50-2-5	AC-HA010822	AC-HA010822-2					
PL18T-301-50-2-5	AC-HA010823	AC-HA010823-2					
PL18X-301-70-2-5	AC-HA010824	AC-HA010824-2					
PL18Y-301-70-2-5	AC-HA010825	AC-HA010825-2					
PL18U-301-70-2-5	AC-HA010826	AC-HA010826-2					
PL18V-301-70-2-5	AC-HA010827	AC-HA010827-2					
PL18W-301-70-2-5	AC-HA010828	AC-HA010828-2					
PL18T-301-70-2-5	AC-HA010829	AC-HA010829-2					

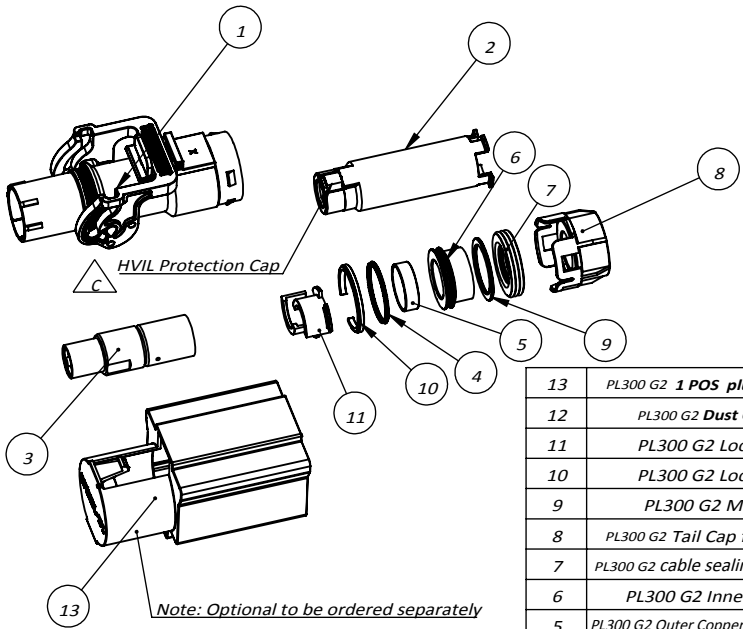

13	PL300 G2 1 POS plug protection cap	1	Order P/N AC-CP001615
12	PL300 G2 Dust Cap for Plug	1	
11	PL300 G2 Lock Housing1	2	Different P/N are used according to different Cable sizes
10	PL300 G2 Lock Housing2	1	
9	PL300 G2 Metal Gasket	1	Different P/N are used according to different Cable sizes
8	PL300 G2 Tail Cap for straight plug	1	Different P/N are used according to different Cable sizes
7	PL300 G2 cable sealing for straight plug	1	Different P/N are used according to different Cable sizes
6	PL300 G2 Inner Copper Ring	1	Different P/N are used according to different Cable sizes
5	PL300 G2 Outer Copper Ring for Straight Plug	1	
4	PL300 G2 Coil Spring for Straight Plug	1	Different P/N are used according to different Cable sizes
3	PL300 G2 Terminal Assy	1	
2	PL300 G2 Insulation Sleeve Assy	1	
1	PL300 G2 Shell Plug Assy	1	Different P/N are used according to different Cable sizes
ITEM	DESCRIPTION	QTY	REMARK

MATERIALS LIST

		Amphenol Technical Products International Asia.				PART NAME:	
		第三角投影 THIRD ANGLE PROJECTION	页面 SHEET	幅面 SIZE	版次 REV.	比例 SCALE	PL300 G2 1POS Straight Plug
签名 SIGNATURE		日期 DATE		UNLESS OTHERWISE SPECIFIED 1) All dimensions are in metric (mm). 2) Tolerances are as follows: 1.PL DEC ± 1.00 2.PL DEC ± 0.50 3.PL DEC ± 0.20		DWG NO:	
制图 DRAWN		Star				03/04/2021	
审核 CHECKED						CUST PART #	
批准 APPROVAL						CUST REV.	