



## 3.5 dBi Embedded PCB Antenna 2,400-2,500 MHz UMCX Connector

### Antennas Technical Data Sheet

PE51210

#### Features

- Highly efficient flex printed circuit board (PCB) design
- Designed for omni-directional applications
- Low profile, compact size
- IPEX, U.FL, UMCX compatible connector

#### Applications

- Integrate into self contained wireless equipment
- Embedded applications requiring integration flexibility
- 2.4 GHz WLAN and Bluetooth

#### Description

The PE51210 is an omnidirectional antenna designed to integrate into devices requiring wireless capability. By embedding these antennas directly into a device, the need for external antennas is eliminated. The omni-directional radiation pattern makes it ideal for multipoint and mobile wireless systems.

#### Configuration

Design	PCB
Band Type	Single
Radiation Pattern	Omni Directional
Polarization	Vertical
Cable Type	1.13mm
Cable Length	3.937 in [100 mm]
Connector Type	UMCX Plug
Number of Ports	1
Housing Material and Plating	Polymer

#### Electrical Specifications

Description	Minimum	Typical	Maximum	Units
Frequency Range	2,400		2,500	GHz
Input VSWR			2:1	
Impedance		50		Ohms
Gain		3.5		dBi
Input Power			5	Watts

#### Mechanical Specifications

Housing Material	Polymer
<b>Size</b>	
Overall Length	1.8503937 in [47 mm]
Width	0.26377953 in [6.7 mm]
Height	0.00629921 in [0.16 mm]

#### Environmental Specifications

##### Temperature

Operating Range	-30 to +75 deg C
Storage Range	-40 to +85 deg C

Click the following link (or enter part number in "SEARCH" on website) to obtain additional part information including price, inventory and certifications: [3.5 dBi Embedded PCB Antenna 2,400-2,500 MHz UMCX Connector PE51210](#)



3.5 dBi Embedded PCB Antenna 2,400-  
2,500 MHz UMCX Connector

Antennas Technical Data Sheet

PE51210

**Compliance Certifications** (see [product page](#) for current document)

**Plotted and Other Data**

Notes:

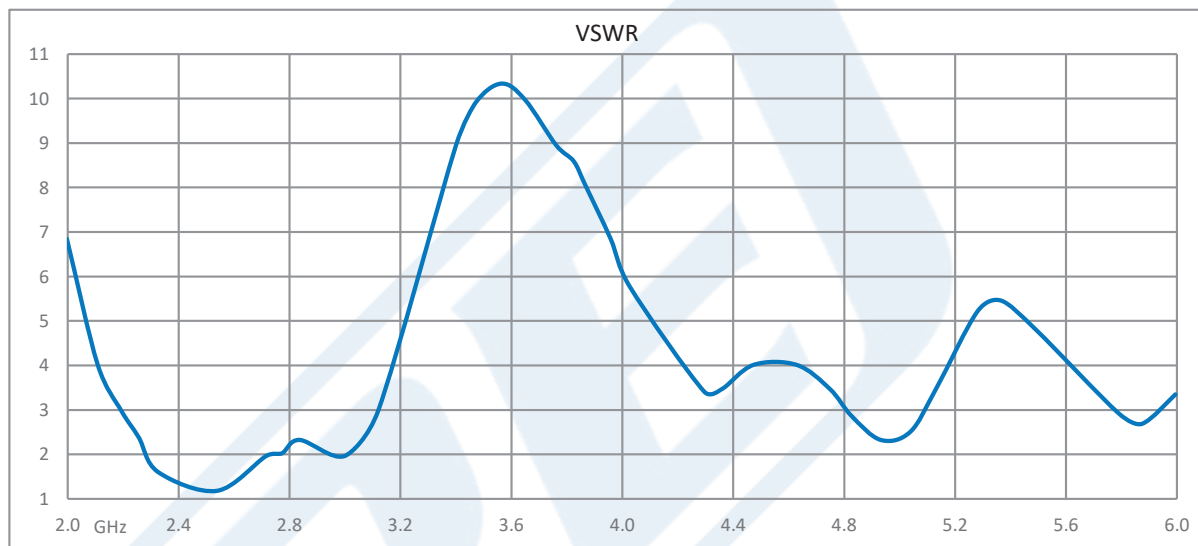

3.5 dBi Embedded PCB Antenna 2,400-2,500 MHz UMCX Connector from Pasternack Enterprises has same day shipment for domestic and International orders. Our RF, microwave and millimeter wave products maintain a 99.4% availability and are part of the broadest selection in the industry.

Click the following link (or enter part number in "SEARCH" on website) to obtain additional part information including price, inventory and certifications: [3.5 dBi Embedded PCB Antenna 2,400-2,500 MHz UMCX Connector PE51210](#)

URL: <https://www.pasternack.com/single-antenna-2.4-2.5-ghz-3.5-dbi-gain-umcx-pe51210-p.aspx>

The information contained in this document is accurate to the best of our knowledge and representative of the part described herein. It may be necessary to make modifications to the part and/or the documentation of the part, in order to implement improvements. Pasternack reserves the right to make such changes as required. Unless otherwise stated, all specifications are nominal. Pasternack does not make any representation or warranty regarding the suitability of the part described herein for any particular purpose, and Pasternack does not assume any liability arising out of the use of any part or documentation.

# PE51210 CAD Drawing

3.5 dBi Embedded PCB Antenna 2,400-2,500 MHz UMCX Connector

REVISIONS			
REV.	DESCRIPTION	DATE	APPROVED
A	INITIAL RELEASE	06/18/2020	KHIETPAS

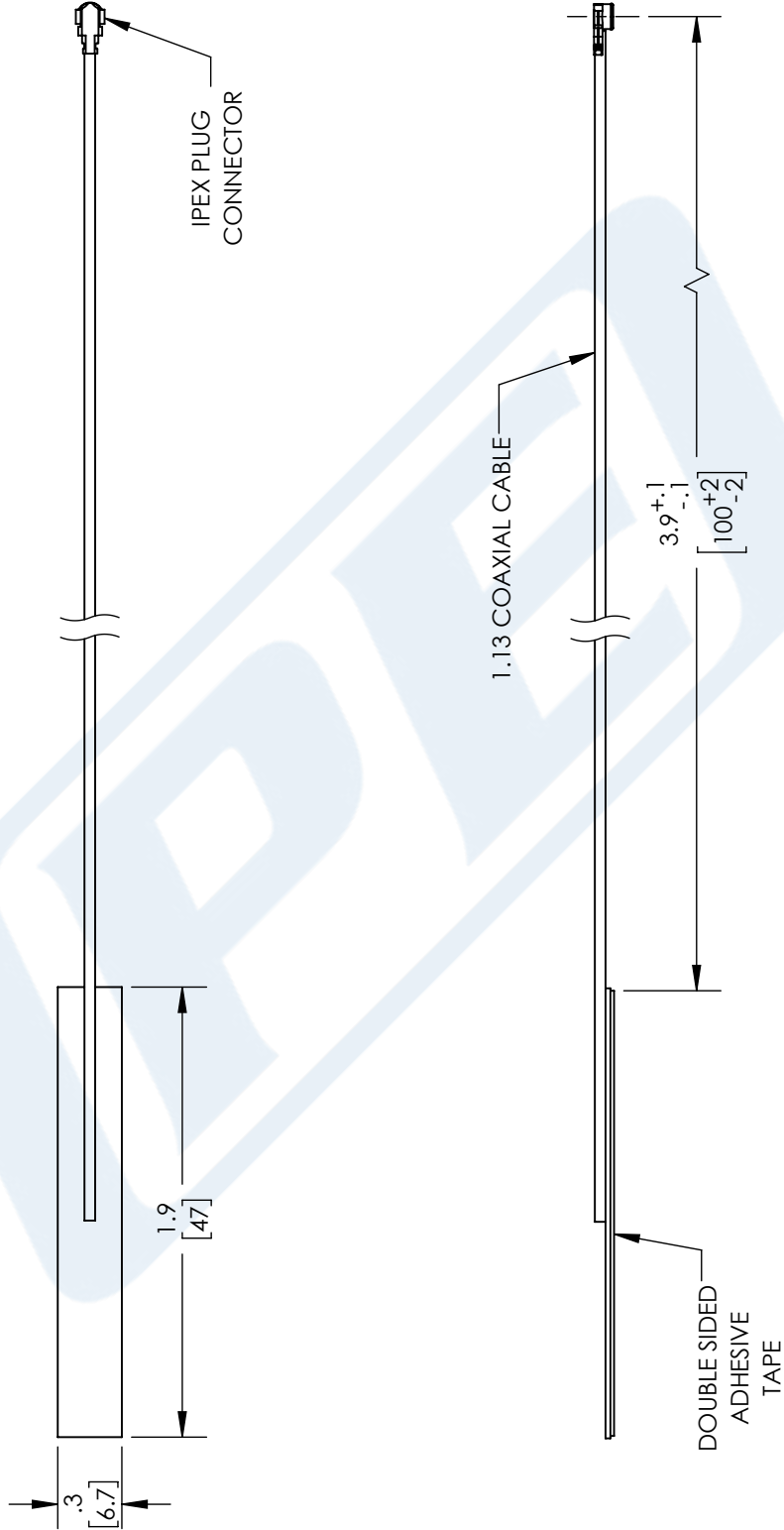

<p>UNLESS OTHERWISE SPECIFIED LEADING DIMENSIONS ARE INCHES DIMENSIONS IN [ ] ARE MILLIMETERS</p> <p>TOLERANCES:</p> <p>.X = ±.2 [ .08]    FRACTIONS ± 1/32          .XX = ±.02 [ .51]    ANGLES ± 1°          .XXX = ±.005 [ .13]</p> <p>CABLE LENGTH (L): TOLERANCES:          L ≤ 12 [305] = +1 [25] / -0          12 [305] &lt; L ≤ 60 [1524] = +2 [51] / -0          60 [1524] &lt; L ≤ 120 [3048] = +4 [102] / -0          120 [3048] &lt; L ≤ 300 [7620] = +6 [152] / -0          300 [7620] &lt; L = +5%L / -0</p> <p>ALL DIMENSIONS SHOWN ARE FOR REFERENCE ONLY.</p>	<p><b>PE PASTERNAK</b> an INFINITI brand</p> <p>Pasternack Enterprises, Inc.          P. O. Box 16759, Irvine, CA 92623.          Phone: 1.949.261.1920   1.866.727.8376          Fax: 1.949.261.7451          Website: www.pasternack.com          E-mail: sales@pasternack.com</p>		<p>THIRD-ANGLE PROJECTION</p> <p>THE INFORMATION AND DESIGN IN THIS DOCUMENT IS THE PROPERTY OF PASTERNAK CORPORATION ALL RIGHTS RESERVED.</p> <p>SHEET 1 OF 1</p> <p>SCALE N/A</p>
	<p>SIZE A</p> <p>CAGE CODE 53919</p> <p>DRAWN BY SLI</p> <p>ITEM NO. PE51210</p>	<p>REV A</p>	

THESE COMMODITIES, TECHNOLOGY OR SOFTWARE WERE EXPORTED FROM THE UNITED STATES IN ACCORDANCE WITH THE EXPORT ADMINISTRATION REGULATIONS. DIVERSION CONTRARY TO U.S. LAW PROHIBITED.