

GENERAL INFORMATION

No. of contacts	from 6 to 100poles, all even numbers
Contact spacing	1,27mm x 1,27mm [0,050"x0,050"]
Test Voltage	500V
Contact resistance	< 25 mOhm
Insulation resistance	≥ 10x10 ⁹ Ω
Working current acc. to IEC 60512, at 70°C, 80% derating	see derating diagram
Working temperature range	-55°C ... +125°C
Termination technology	SMT
Reflow processing temperature (acc. to ECA/IPC/JEDEC J-STD-075 Level PSL R0)	min. 150s >217°C min. 30s >240°C
Clearance & creepage distance	0,4mm min.
Insertion force (depending on mating connector)	approximately 0,5N/contact
Withdrawal force (depending on mating connector)	approximately 0,5N/contact
Mating cycles	PL1 : 500 mating cycles PL2 : 250 mating cycles
RoHS - compliant	Yes
Leadfree	Yes
Working voltage acc. to IEC 60664-1	100V / 150V (depending on installation category)
UL file acc. UL 1977	ECBT2.E102079
UL file acc. CSA-C22.2 (for Canada)	ECBT8.E102079
PSL level acc. ECA/IPC/JEDEC J-STD-075	PSL R0
MSL level acc. ECA/IPC/JEDEC J-STD-020D	MSL 1

INSULATOR MATERIAL

Material	LCP (liquid crystalline polymer)
Color	Black
UL classification	UL94-V0
Material group acc. IEC 60664-1	IIIa (175 ≤ CTI < 400)

CONTACT MATERIAL

Contact material	Copper alloy
Plating termination zone	Sn
Plating contact sliding side	Au over PdNi (acc. to Performance level)

DERATING DIAGRAM acc. to IEC 60512-5 (Current carrying capacity)

The current carrying capacity is limited by maximum temperature of materials for inserts and contacts including terminals.
The current capacity curve is valid for continuous, non interrupted current loaded contacts of connectors when simultaneous power on all contacts is given, without exceeding the maximum temperature.

Control and test procedures according to DIN IEC 60512-5
derating curve at I_{max}*0,8 (IEC 60512-5-2)

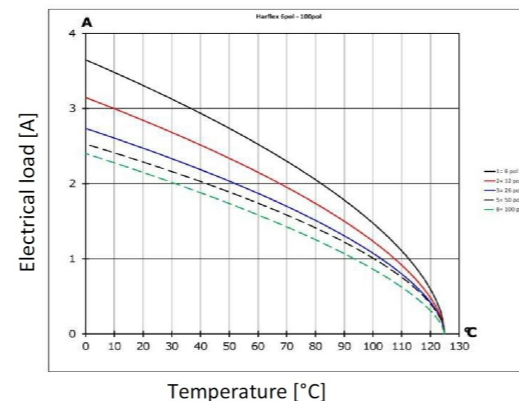

RECOMMENDATION FOR SOLDER PROCESSING

Solder paste recommendation

The har-flex connectors are solderable with established lead-free SAC / SnNi solder but also leaded solder e.g. SnPb40

PCB pad plating

The har-flex connectors are solderable on lead-free pad surfaces like HAL, NiAu, Immersion Sn.

Stencil recommendation

The solder deposition has to be placed on the pad area of the contact solder tines. Ideally, the solder deposition has the same length-to-width ratio and center point like the PCB pads. The size of the solder stencil apertures is depending on the thickness of the stencil. In general, the thinner stencils will need larger apertures to result in the required volume of solder paste. The minimum required solder paste volume for the signal pins is 0,077mm³, for the hold down it is 0,39mm³. For example, this can be achieved with the following stencil data :

Stencil thickness	Signal pins		
	PCB pad size	proposal stencil aperture size	calculated solder paste volume
150 μm	0,8 x 0,8 mm	0,72 x 0,72 mm	0,078 mm ³

Stencil thickness	Hold-downs		
	PCB pad size	proposal stencil aperture size	calculated solder paste volume
150 μm	2,7 x 1,2 mm	2,43 x 1,08 mm	0,394 mm ³

If a stencil with lower thickness shall be used, please insure the minimum required solder paste volume by enlarging the stencil aperture. Depending on the PCB design, the solder deposition may protrude the PCB pads. But to achieve a good sealing during solder paste printing and to reduce the cleaning interval of the stencil, the aperture should be smaller than the PCB pad about 10% or 25μm encircling.

Coplanarity of contacts

All connectors are tested for coplanarity of contacts and are in the range of
6 pin to 50 pin: ≤ 0,1mm
52 pin to 68 pin: ≤ 0,12mm
70 pin to 80 pin: ≤ 0,13mm
82 pin to 100 pin: ≤ 0,15mm

Performance level

Performance level 1 (recommended for majority of applications)
Initial 250 mating cycles, 10 days gas test (25°C / 75% r.h.) using H2S 10 ppb, NO2 200 ppb, CL2 10 ppb, SO2 200 ppb. Measurement of contact resistance. The remaining 250 mating cycles are subject to measurement of contact resistance and visual inspection.

Visual inspection. No abrasion of the contact finish through to the base material. No functional impairment.
Part number definition : 15 2

Performance level 2

Initial 125 mating cycles, 4 days gas test (25°C / 75% r.h.) using H2S 10 ppb, NO2 200 ppb, CL2 10 ppb, SO2 200 ppb. Measurement of contact resistance. The remaining 125 mating cycles are subject to measurement of contact resistance and visual inspection.

Visual inspection. No abrasion of the contact finish through to the base material. No functional impairment.
Part number definition : 15 6

Performance level S4

Defined contact surface of min. 0,06 μm Au over 0,7+0,2μm PdNi
Part number definition : 15 5

	All rights reserved	Created by ZHUANGJ	Inspected by LUOK	Standardisation HOFFMANN	Date 2020-07-29	State Final Release
	Department EL PD	Title har-flex male angled		Doc-Key / ECM-Nr. 100578045/UGD/000/D 500000177026		
HARTING Electronics GmbH D-32339 Espelkamp		Type DS	Number 15151200301		Rev. D	Page 1/2



har-flex angled male connector

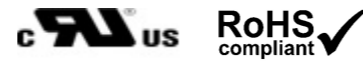

TAPE LAYOUT & PACKAGING

Tape acc. to IEC 60286-3

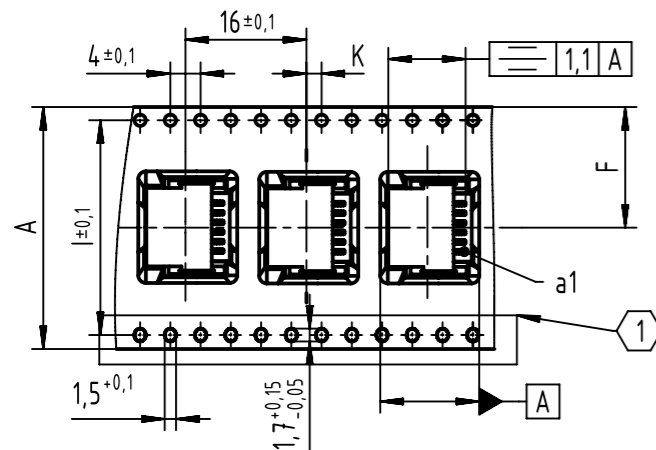

Tape dimensions:	A	F	I	K
poles 06 to 12	24,0 \pm 0,3/-0,1	11,5 \pm 0,1	-	2 \pm 0,1
poles 14 to 20	32,0 \pm 0,3	14,2 \pm 0,1	28,4	2 \pm 0,1
poles 22 to 40	44,0 \pm 0,3	20,2 \pm 0,1	40,4	2 \pm 0,15
poles 42 to 56	56,0 \pm 0,3	26,2 \pm 0,1	52,4	2 \pm 0,15
poles 58 to 80	72,0 \pm 0,3	34,2 \pm 0,3	68,4	2 \pm 0,2
poles 82 to 100	88,0 \pm 0,3	42,2 \pm 0,3	84,4	2 \pm 0,2

1 NO DOUBLE SPROCKET HOLES FOR 06, 08, 10 AND 12 POLE NUMBERS (TAPE SIZE 24)

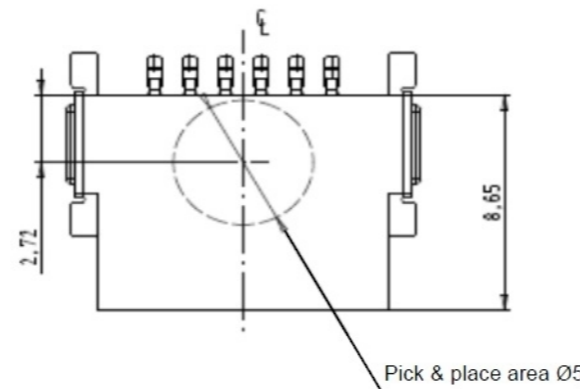

Packaging indices ("XXX" in part number)		
Index	Packaging unit	Packaging
000	560	Tape & reel
333	1	Tape

REEL DIMENSIONS

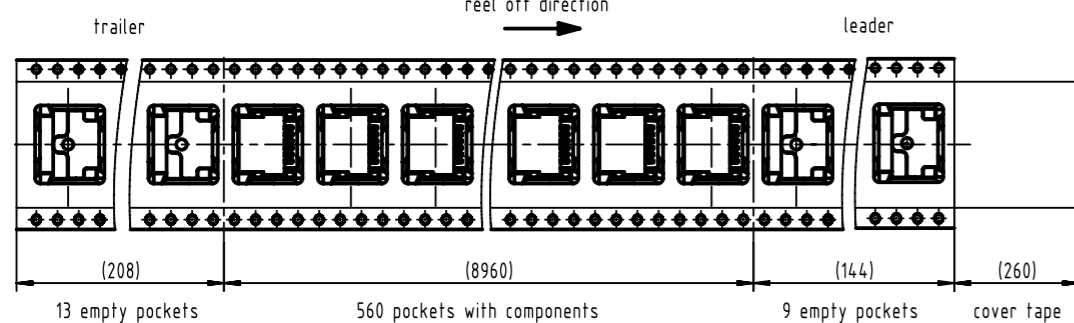
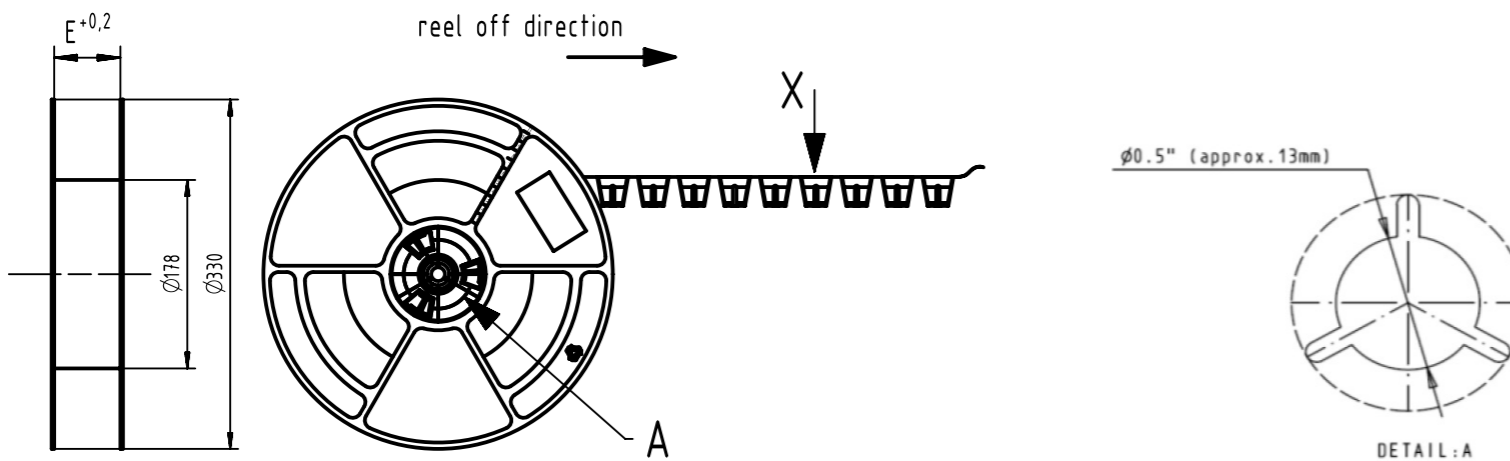

Reel dimensions:	E
Poles 06 to 12	24,4
Poles 14 to 20	32,4
Poles 22 to 40	44,4
Poles 42 to 56	56,4
Poles 58 to 80	72,4
Poles 82 to 100	88,4

APPLICATION INFORMATION

angled male

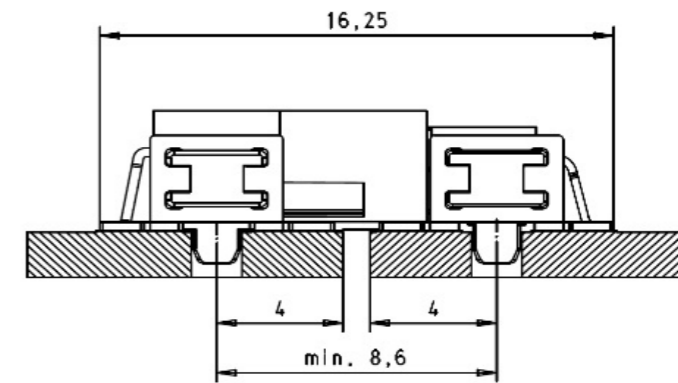

angled female

angled male

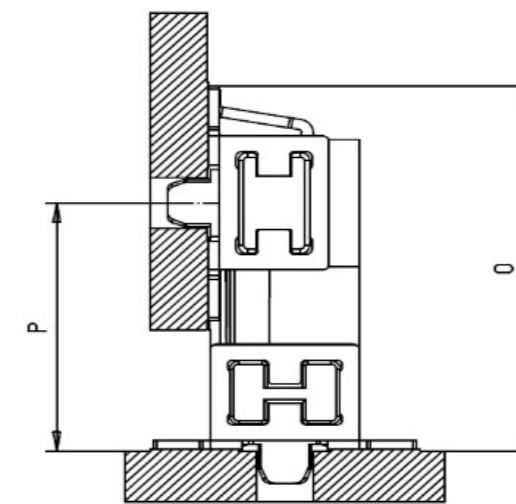

straight female

13,65	15,1	18,93
9,05	10,5	14,33
6,25	7,7	11,53
Y	P min.	0

Admissible mismatching

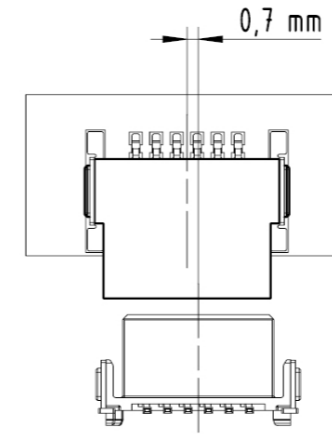

Admissible inclination

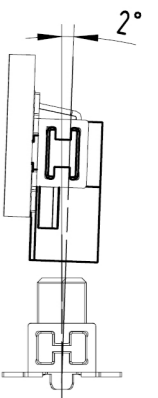
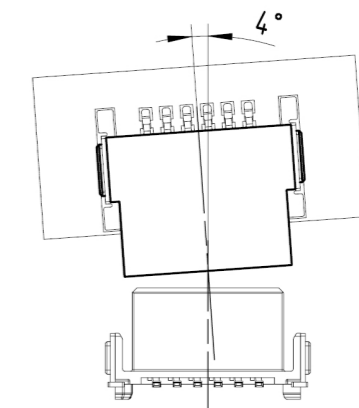
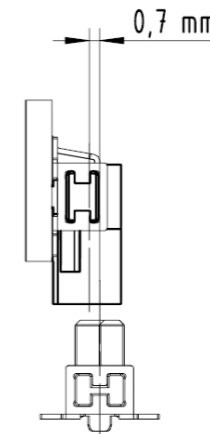

All Dimensions in mm
Original Size DIN A3

Scale
1:1

Free size tol.

Ref.

Sub.



All rights reserved
Department EL PD

Created by
ZHUANGJ

Inspected by
LUOK

Standardisation
HOFFMANN

Date
2020-07-29

State
Final Release

Title
har-flex male angled

Type
DS

Number
15151200301

Doc-Key / ECM-Nr.
100578045/UGD/000/D
500000177026

Rev.
D

Page
2/2

HARTING Electronics GmbH
D-32339 Espelkamp