

HPP V4 Signal THT 10-pole vertical jack



Image is for illustration purposes only. Please refer to product description.

Part number	09 45 545 9012
Specification	HPP V4 Signal THT 10-pole vertical jack
HARTING eCatalogue	https://b2b.harting.com/09455459012

Identification

Category	Connectors
Series	HARTING PushPull (V4)
Identification	Signal
Element	Solder jack
Specification	Straight

Version

Termination method	Solder termination
Shielding	Fully shielded, 360° shielding contact
Number of contacts	10

Technical characteristics

Contact spacing (termination side)	2.4 mm
	3 mm
Contact spacing (mating side)	2.4 mm
	3 mm
Rated current	5 A
Rated voltage	50 V
Rated impulse voltage	1.5 kV
Pollution degree	3
Clearance distance	≥1.4 mm
Creepage distance	≥1.4 mm
Insulation resistance	>10 ⁹ Ω
Contact resistance	≤10 mΩ



Pushing Performance
 Since 1945

Technical characteristics

Limiting temperature	-40 ... +85 °C
Insertion force	50 N
Withdrawal force	50 N
Mating cycles	≥500
Test voltage $U_{r.m.s.}$	1.5 kV (contact-contact) 1.5 kV (contact-ground)
Isolation group	I ($600 \leq CTI$)
Vibration resistance	10-500 Hz, 5 g, 0.35 mm, 10 sweep cycles acc. to IEC 61373 Category 1 Class B
Shock resistance	50 g / 11 ms, 10 shocks / axis and direction

Material properties

Material (contacts)	Copper alloy
Surface (contacts)	Noble metal over Ni Mating side Sn over Ni Termination side
RoHS	compliant with exemption
RoHS exemptions	6(c): Copper alloy containing up to 4 % lead by weight
ELV status	compliant with exemption
China RoHS	50
REACH Annex XVII substances	Not contained
REACH ANNEX XIV substances	Not contained
REACH SVHC substances	Yes
REACH SVHC substances	Lead
California Proposition 65 substances	Yes
California Proposition 65 substances	Lead Nickel

Specifications and approvals

Specifications	IEC 61076-3-106 Variant 4 (V4)
UL / CSA	UL 1977 ECBT2.E102079 CSA-C22.2 No. 182.3 ECBT8.E102079
Approvals	DNV GL

Commercial data

Packaging size	40
Net weight	5.79 g

Commercial data

Country of origin	China
European customs tariff number	85366990
GTIN	5713140061477
eCl@ss	27440205 Contact insert for industrial connectors

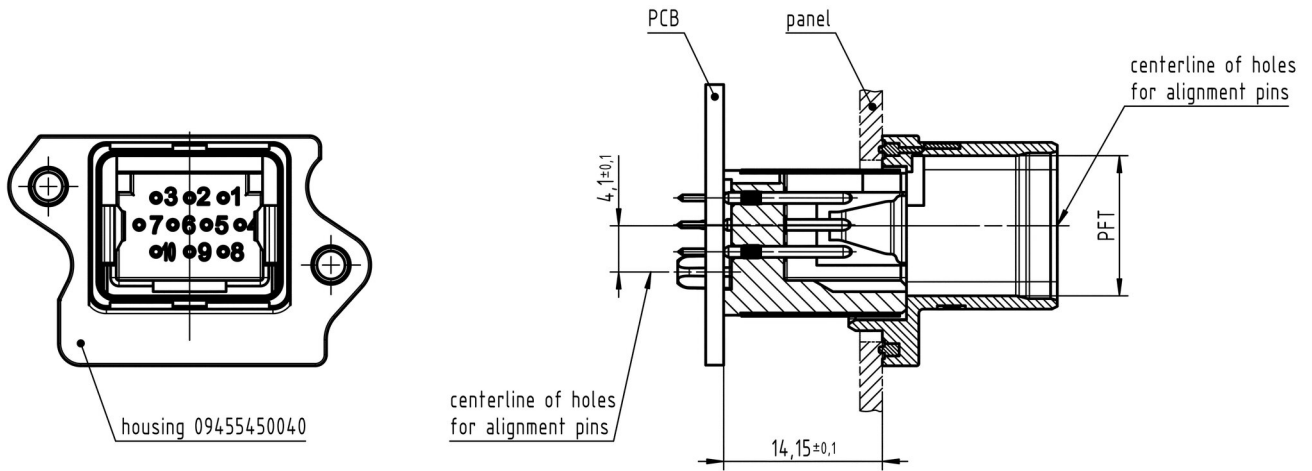

Tray

