

1	NDK Part Number	See table 1
2	NDK Specification Number	See Table1
3	Type	NX3225SA
4	Electrical Characteristics	
4.1	Nominal Frequency (f_{nom})	See table 1
4.2	Overtone order	Fundamental
4.3	Frequency Tolerance	$\pm 15 \times 10^{-6}$ max. (+25 °C)
4.4	Frequency Versus Temperature Characteristics	$\pm 15 \times 10^{-6}$ max. (-10 ~ +75 °C) The reference temperature shall be +25 °C
4.5	Equivalent Series Resistance (R_r)	See table 1
4.6	Shunt Capacitance (C_0)	NA
4.7	Maximum Drive Level	100 μ W max.
5	Measurement Circuit	
5.1	Frequency Measurement	
5.1.1	Measuring Instrument	IEC π -network
5.1.2	Load Capacitance (C_L)	8 pF
5.1.3	Level of Drive	10 μ W
5.2	Equivalent Resistance Measurement	
5.2.1	Measuring Instrument	IEC π -network
5.2.2	Load Capacitance (C_L)	Series
5.2.3	Level of Drive	10 μ W
6	Operable Temperature Range	-10 ~ +75 °C
7	Storage Temperature Range	-40 ~ +85 °C
8	Dimension	

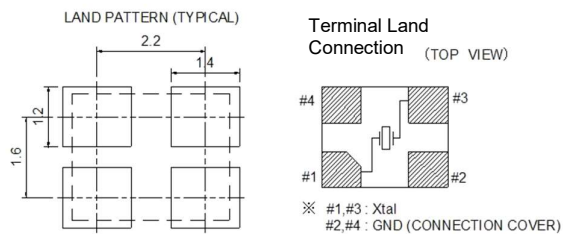
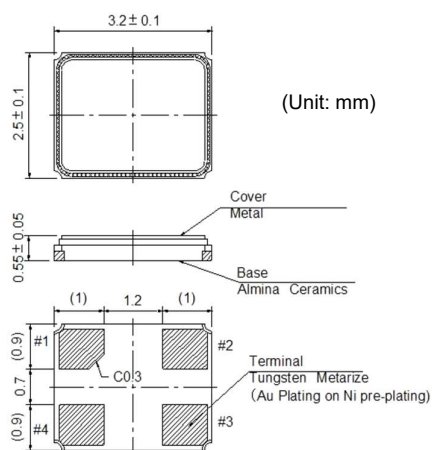

Table1

f_{nom} (MHz)	R_r (Ω) max.	NDK Spec Number	NDK Part Number	Prior NDK Part Number
12.000	100	EXS00A-CS15202	CS15202-12M	NX3225SA-12.000M-STD-CSR-3
12.288	100	EXS00A-CS15187	CS15187-12.288M	NX3225SA-12.288M-STD-CSR-3
13.560	80	EXS00A-CS15188	CS15188-13.56M	NX3225SA-13.56M-STD-CSR-3
25.000	50	EXS00A-CS14517	CS14517-25M	NX3225SA-25.000M-STD-CSR-3
26.000	50	EXS00A-CS14518	CS14518-26M	NX3225SA-26.000M-STD-CSR-3
27.120	50	EXS00A-CS14516	CS14516-27.12M	NX3225SA-27.12M-STD-CSR-3
30.000	50	EXS00A-CS15191	CS15191-30M	NX3225SA-30.000M-STD-CSR-3