



NT-Series Operator Interface Terminals



Software

High Function Touch Screens
NT21/31/631

Basic Function Touch Screens
NT20S/600S

Large Function Key Unit
NT11S

Small Function Key Units
NT2S

Technical Highlights

... PROCESS DISPLAY PROBLEMS?

solve it™ here!

Take the Right Action at the Right Time

The increased speed demanded by growing productivity goals makes your operators' decision skills more critical than ever. They need clearly displayed information at real-time speed to respond effectively. Omron's operator interface terminals let you control and access critical information from a single point to help operators stay on top of your process. The graphic and message development software to support the terminals has a short learning curve so your application will be ready sooner for commissioning. Omron's NT-series operator interface terminals offer the right solution at the right time.

Choose an Experienced Partner

With over 65 years of experience manufacturing industrial controls, Omron brings the know-how and reliable products to help you solve tough production problems. Whether you choose to use Omron operator interface terminals with Omron programmable controllers or with those from other manufacturers, we can work with you to develop a flexible and cost-effective system that responds to your current and future needs. Expertise in packaging, material handling, electronics and small parts assembly, food and beverage, semiconductor manufacturing and other specialized applications makes Omron an experienced partner well-qualified to help with your project.

World Recognized Versatility and Support

Omron products represent the best value in capabilities for the investment. Our product designs meet international safety ratings (UL, CE) to speed certification of machinery for commissioning or export. Easy-to-use, multilingual display capabilities and translation utility in the development software give you advantages in providing information to operators in their local language without having to modify the graphics to accommodate each language. With global sales and support that provide spare parts and service locally, you can confidently design in Omron operator interface terminals for machinery going all over the globe.



Strong Products and Intuitive Software Combine for Great Performance

- Wide selection of touch screens and function key models include everything from simple touch switches, lamps, bar graphs and text to models that handle animation, recipes, trend graphs and background math calculation.
- Easy-to-use graphical development software NT-Series Support Tool provides a Windows®-based environment with menu driven, drag-and-drop programming. Manage project screens and tables from a convenient tree menu. Many features shorten debugging time to shorten startup.
- Get more live area and less bezel with Omron's NEMA 4 touch screens for efficient use of panel real estate. Shallow mounting depth of less than 2 inches allows thinner panel designs.
- Rigorous testing every step of the way ensures smooth installation and commissioning. Firmware programming, communications drivers and hardware are tested individually and in combination for flawless performance. Each terminal undergoes thermal, noise, vibration and shock testing to withstand extreme conditions defined in our specifications.
- Versatile communications, faster updates provide the flexibility you need to get information to operators. Omron's NT Link protocol provides high-speed serial transmission (up to 115k baud) for one or multiple terminals and one PLC. Create screen programs that do not require modification across multiple PLC platforms using the DeviceNet communications capability. Memory Link protocol allows the terminal to communicate with a serial port on a PC or custom board.



Contents

Selection Guide	4 - 5
Warranty	6
Programming Software	7 - 11
Operator Interface Terminals	13
High Function Touch Screens NT21 / NT31 / NT631	14 - 21
Basic Function Touch Screens NT20S / NT600S	22 - 25
Large Function Key Unit NT11S	26 - 29
Small Function Key Units NT2S	30 - 33
Technical Highlights	35
Cable Solutions for Omron PLCs	36 - 39
Cable Solutions for Multi-Vendor PLCs	40 - 44
NT Link Connection	45
DeviceNet Communications	46 - 48
Memory Link	49 - 51
Solve It Center - Omron Products	52 - 53
Worldwide Sales Offices	54 - 55

Selection Guide

Software

NT21/31/631

NT20S/600S

NT11S

NT2S

Technical Highlights

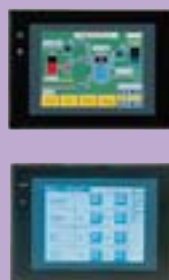

NT631

NT31

NT21

Display		NT631	NT31	NT21
Type		STN, TFT, Electroluminescent	STN	STN
Size		10.4 or 11.3 inch diagonal	5.7 inch	5.2 inch
Resolution		640 x 480 pixels	320 x 240 pixels	260 x 140 pixels
Interface		Touch screen	Touch screen	Touch screen
Memory				
Type		1 Mb, Flash EPROM	1 Mb, Flash EPROM	512 Kb, Flash EPROM
Max. screen storage		3999	3999	3999
Features				
Freeform drawing	Yes	Yes	Yes	
Bitmap	Yes	Yes	Yes	
Tiling (color or texture fill)	Yes	Yes	Yes	
Bar graph	Yes	Yes	Yes	
Needle gauge	Yes	Yes	Yes	
Line trending	Yes	Yes	Yes	
Thumbwheel	Yes	Yes	Yes	
Bit controlled input lockout	Yes	Yes	Yes	
Recipe table	Yes	Yes	Yes	
Math function	Yes	Yes	Yes	
Programming console	Yes	Yes	Yes	
Pop-up windows	Yes	Yes	Yes	
Device monitor function	Yes	Yes	No	
Real time clock	Yes	Yes	No	
Printer port	Yes	Yes	No	
Memory unit support	Yes	Yes	Yes	
Communications			Yes	
Host link	Yes	Yes	Yes	Yes
NT link	Yes	Yes	Yes	Yes
High-speed NT link	Yes	Yes	Yes	Yes
Allen-Bradley	Yes	Yes	Yes	No
GE Fanuc	Yes	Yes	Yes	No
Mitsubishi	Yes	Yes	Yes	No
Siemens	Yes	Yes	Yes	No
Modicon	Yes	Yes	Yes	No
Memory Link	Yes	Yes	Yes	Yes
General specifications				
Overall dimensions mm (in)		315 W x 250 H x 54 D (12.40 x 9.84 x 2.13)	196 W x 142 H x 54 D (7.72 x 5.59 x 2.13)	190 W x 110 H x 53.5 D (7.48 x 4.33 x 2.11)
Panel cutout mm (in)		303 W x 238 H (11.93 x 9.38)	184 W x 131 H (7.24 x 5.16)	100.5 W x 178.5 H (3.96 x 7.03)
Operating voltage		24 VDC	24 VDC	24 VDC
Max. power		18 W	15 W	7 W
Ratings		NEMA 4	NEMA 4	NEMA 4
Approvals		UL/CSA/CE	UL/CSA/CE	UL/cULus/Class I Div 2

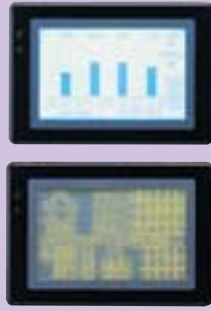
NT600S
NT20S
NT11S
NT2S

Display				
Type	STN, Electroluminescent	Backlit STN LCD	Backlit LCD	Backlit LCD
Size	9 inch diagonal	5 inch diagonal	4 line x 20 character	2 line x 16 character
Resolution	640 x 400 pixels	256 x 128 pixels	160 x 64 pixels	–
Interface	Touch screen	Touch screen	Alphanumeric	6 function keys
Memory				
Type	Flash EPROM	Flash EPROM	Flash EPROM	Flash EPROM
Max. screen storage	500	500	250	250
Features				
Freeform drawing	Yes	Yes	No	No
Bitmap	No	No	No	No
Tiling (color or texture fill)	No	No	No	No
Bar graph	Yes	Yes	Yes	Yes
Needle gauge	No	No	No	No
Line trending	No	No	No	No
Thumbwheel	Yes	Yes	No	No
Bit controlled input lockout	No	No	No	No
Recipe table	No	No	No	No
Math function	No	No	No	No
Programming console	No	No	No	No
Pop-up windows	No	No	No	No
Device monitor function	No	No	No	No
Real time clock	No	No	No	No
Printer port	No	No	Yes	No
Memory unit support	No	No	No	No
Communications				
Host link	Yes	Yes	Yes	Yes
NT link	Yes	Yes	Yes	No
High-speed NT link	No	No	No	No
Allen-Bradley	No	No	No	Yes
GE Fanuc	No	No	No	Yes
Mitsubishi	No	No	No	Yes
Siemens	No	No	No	Yes
Modicon	No	No	No	Yes
Memory Link	No	Yes	No	No
General specifications				
Overall dimensions mm (in)	275 W x 192 H x 71 D (10.83 x 7.56 x 2.80)	190 W x 110 H x 58 D (7.48 x 4.33 x 2.28)	218 W x 113 H x 38.2 D (8.58 x 4.45 x 1.50)	91 W x 44 H x 28 D (3.58 x 1.73 x 1.10)
Panel cutout mm (in)	263.5 W x 180.5 H (10.37 x 7.11)	101 W x 178.5 H (3.98 x 7.03)	98.5 W x 203.5 H (3.87 x 8.01)	45 W x 92 H (1.8 x 3.6)
Operating voltage	24 VDC	24 VDC	24 VDC	5 VDC/24 VDC
Max. power	25 W (EL), 15 W (LCD)	10 W	10 W	0.75 W/1.5 W
Ratings	NEMA 4	NEMA 4	NEMA 4	IP65
Approvals	UL/CSA/CE	UL/CSA/CE	UL/CSA/CE	UL/CSA/CE

Software

NT21/31/631

NT20S/600S

NT11S

NT2S

Technical Highlights

NOTE: Throughout this catalog, many of the product dimensions are shown in both millimeters and inches. When both are not shown, divide millimeters by 25.4 to calculate inches.

NOTE: Specifications subject to change without notice.

Warranty: Omron certifies all of its products either meet or exceed stipulated specifications one year from the date of purchase. Omron is not liable for stenographic and/or clerical errors.

Omron's obligation under this warranty is limited solely to repair or replacement at Omron's discretion. Omron will not be liable for any design furnished by Buyer and incorporated into equipment.

This warranty is voided if the product is altered in any way or suffers consequential damage due to negligence or misuse.

Omron is not to suffer risk due to the suitability or unsuitability or the results of the use of its products used in combination with any electrical or electronic components, circuits, systems, assemblies or any other materials or substances or environments.

The foregoing warranty is the only warranty which Omron Electronics LLC provides with respect to the products listed herein. No other warranties, expressed, implied or statutory shall apply, whether as to merchantability, fitness for a particular purpose, description, or otherwise.

Limitation of Liability: Notwithstanding any other statement herein, Omron Electronics LLC, its contractors and suppliers shall not be liable for any special, indirect, incidental or consequential damages. The remedies of the purchaser set forth herein are exclusive where so stated, and the total cumulative liability of Omron Electronics LLC, its contractors and suppliers, with respect to this contract or anything done in connection therewith, shall not exceed replacement price reimbursement as to the product on which such liability is based.

NT-Series Support Tool Graphic Development Software

- Drag-and-drop, windowed workspace
- Import I/O and comments from CX-Programmer
- Translation Support Utility to manage a project in multiple languages
- Simulation of the ON/OFF states for control objects
- Copy and paste from screen to screen, and project to project
- Tables for managing numeral, string, bit, math, and recipe information
- View and edit bitmap images in the Image Table
- Symbol manager includes ISO 7000 image library
- Use pre-built or customized keypads
- Object alignment tools
- Global address change tool
- Error log with hot links to the error
- 10 levels of undo/redo



Omron's NTST software lets you create, debug and manage operator interface terminal programs in a familiar Windows® environment with drag-and-drop convenience. The short learning curve to produce clear, easy-to-use screens reduces the time to commissioning.

Freedom to Design Screens Your Way

The NT-series HMIs offer unmatched programming flexibility, allowing screens to be designed to meet your control needs. The programming software, NTST, unlocks this flexibility. For instance, some NT models allow memory to be allocated to numeral and string tables based on your needs. Configure objects from the drag-and-drop toolbar and add finishing touches using a variety of drawing tools. A library of standard ISO 7000 symbols can be used to denote actions, items, and conditions. Preconfigured or custom keypads can be integrated for numeric entry. Project data is managed from a series of easily navigated tables for storing numeric, bit, string, image, recipe, and math function data. Control and display objects that reference these tables can utilize indirect addressing, where the PLC can specify the table location to be accessed, allowing one screen object to reference multiple table locations. A parent/child option allows complex screens to be created from parts that can be used over and over again, reducing

programming and utilizing memory more efficiently. Also, addressing in the NT unit is direct to the memory locations within the PLC, regardless of PLC vendor. This allows programs to be created using the addressing schemes familiar to the PLC programmer.

Cut Debugging Time

NTST employs a variety of features that allow programming and debugging time to be compressed. Download one screen at a time to the NT unit to check out new screens or minor edits. Upload individual items such as the different data tables, screens, alarm history and screen history logs, and recipe settings. Object filters in the screen editor allow only a specific object type to be shown, to simplify editing of complex screens. An error log includes hot links to the actual error, so that they can be viewed and corrected quickly. The ON/OFF states and flashing properties of objects can be checked in the programming environment of NTST to avoid simple mistakes in formatting.

Ordering Information

Description	Part Number
NT Series Support Tool v 4.6	NT-ZJCAT1-EV4
Programming Cable 9-9 pin	C200H-CN229-EU

Models Supported

NT Series Support Tool can be used with the following models: NT11S, NT20S, NT30, NT30C, NT21, NT31, NT31C, NT600S, NT620S, NT620C, NT631, NT631C

System Requirements

Computer	Operating System
<ul style="list-style-type: none"> • IBM PC or 100% compatible Pentium 100 MHz or faster processor • 32 Mbytes memory minimum • At least 35 Mbytes free area on hard disk (for installing Support Tool, System Program, System Installer and Supplement Symbols) 	<ul style="list-style-type: none"> • Another 15 MB required for Parts Collection for Support Tool • CD-ROM drive • VGA compatible display • Serial or bus mouse
<p>Microsoft® Windows® 95, Windows® 98, Windows® NT Version 4.0 (Service Pack 3 or later)</p>	<p>RS-232C cable to transmit screen data</p>

Tools to Organize Your Design

NTST takes full advantage of the drag-and-drop, windowed, dialog-box-driven environment. A handy and familiar tree-style project window helps you organize the project. Drop-down menus provide quick access to all programming areas and actions needed to configure a project. A helpful status bar at the bottom of the screen shows the NT touch screen and PLC vendor for this program. A series of tables listed in the Tools menu and project tree allow quick access to numeric, recipe, string, and background math setup information. The project information and programming tools are readily available to make programming and maintaining project from NTST a breeze.

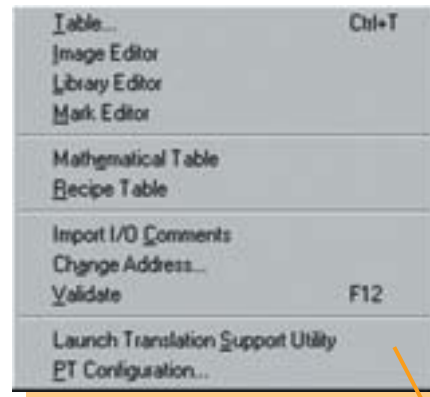

Tools Menu



File Menu

Tree-style Project Menus

Presents project data on an organized, familiar tree structure. Quickly access screens and tables within a project.

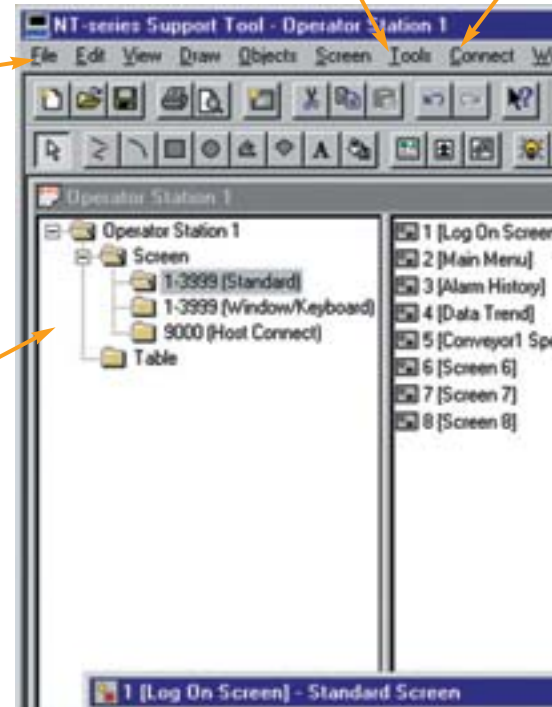

Pre-built Input Keypads

A variety of keypad layouts are available from the Symbol Library included with NTST.

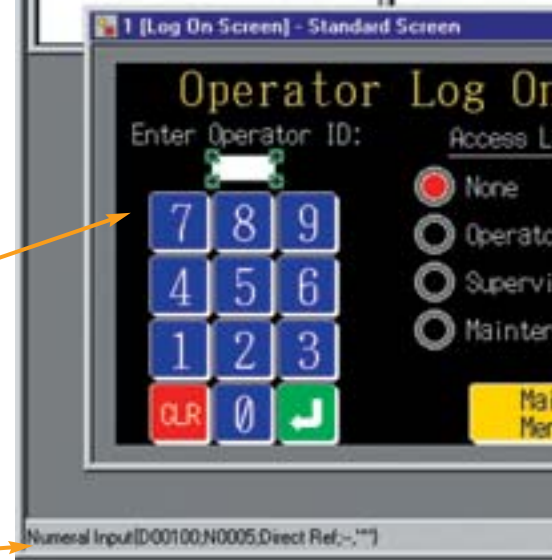

Status Bar

Shows details about the highlighted object. For control objects, critical programming information is shown.

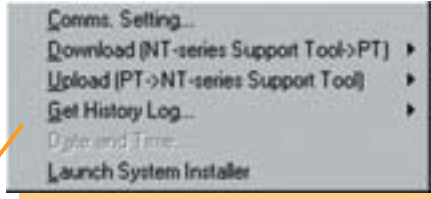

Connect Menu

Label Centering Tool

Centers labels with touch switch and lamp objects.

Drag & Drop Control Object Toolbar

Object Filter

Reduce clutter on a screen in order to edit a buried object of a certain type.

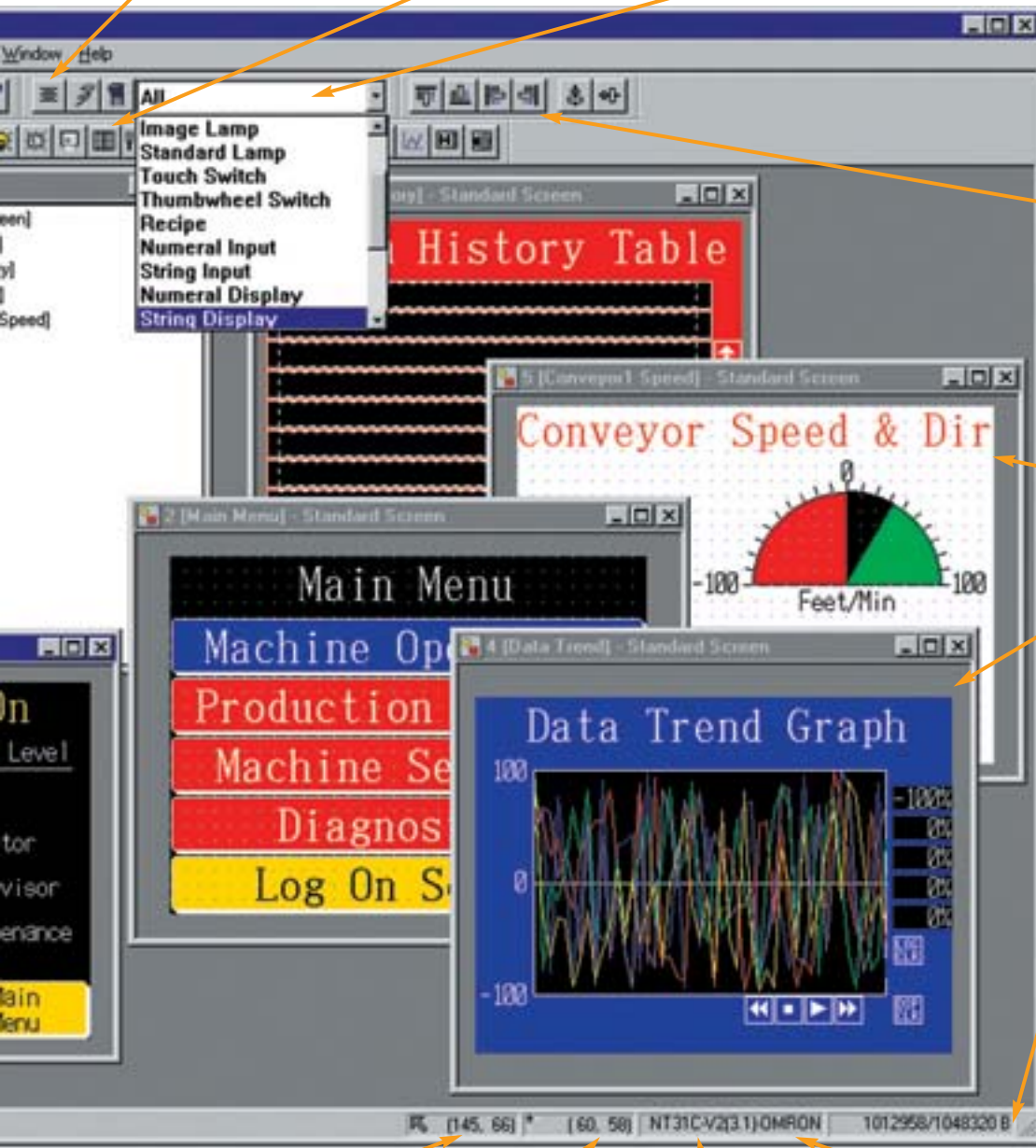

Alignment Tools

Select a group of objects and align them top, bottom, left, right, center vertically or horizontally.

Windowed Environment

Remaining NT Memory/ Total NT Memory

Determine how much more room you have to program in the NT unit's memory.

Cursor Position

Top-left Coordinate of Selected Object

Project Model Setting

PLC Vendor

Translation Support Utility

If your equipment is used overseas, the NTST Translation Utility reduces time and costs associated with the translation and maintenance of translated screen projects. After you create a program, import it into the Translation Utility where the text strings will be automatically stripped from the project and displayed in the first column, column A, of a database. Next, create a second column, column B, that will store the new language text. Have the translator simply translate the words in column A into column B. Then a menu command, Generate, is selected to create a new screen project containing the translated text. This can be repeated within the same database for up to six languages.

Works with Most NT-Series Touch Screens

The Translation Utility works with projects developed for NT11S, NT20S, NT21, NT31, NT600, and NT631 touch screens.

Debugging Time and Validation Time Savings

Each new language file is simply the master English file with the English text swapped out for translated text. This means only one master screen project must be maintained. Maintain only one engineering project!

The work of the translator is greatly simplified. The language translation activity can take place in Microsoft Access or Excel, not in NTST. This means your translators do not have to hunt through the screen project trying to locate text strings. It also means your translators do not have to be screen programming experts. If they can read a column of text in Excel, they can translate your entire project!

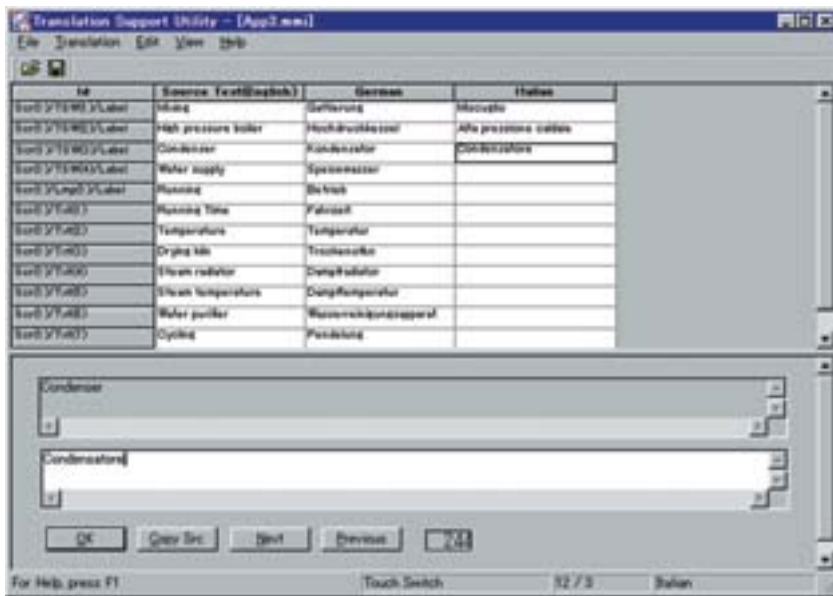

Modifying Existing Programs

Updating the master program is infinitely easier with the NTST Translation Utility. No longer do engineering changes need to be made to the master project and all translated files. Make the engineering changes to the master project and then simply re-import the master project into the existing translation database for that project. The translation support utility automatically compares contents of the new master project to the original import and identifies areas where text changes. Existing translation work is maintained and is automatically reused. New text that requires translation is added to the database. Select Generate once the touch-up translation is complete to create the final translated projects.

Languages

Translation Utility supports these languages:

- English
- Spanish
- French
- Japanese
- Chinese (Simplified and Traditional)
- German
- Italian

System Installer

Quickly update the firmware program of the operator interface using the NTST system installer. This software utility allows programmers to select from a variety of firmware programs for specific NT model types and then transfer the firmware to the NT unit. Use the System Installer to upgrade to newer versions of firmware or download firmware for different communications drivers.

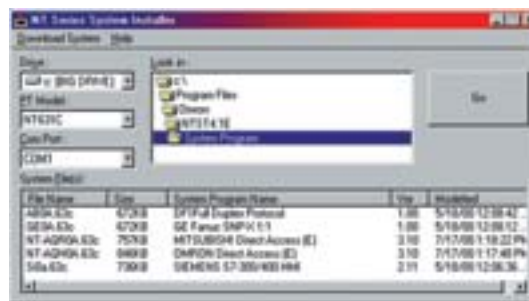

String Table

Data strings tie ASCII data to a PLC memory location for reading or writing, and display in lamps, switches and text blocks. Strings can be referenced from anywhere in the project, including alarm histories and string displays. The string table lets you organize them for easy reference.

Models NT21/31/631 allow string table entries to be expanded from 256 (default) to 1000 or 2000 entries. Larger string tables consume NT memory resources.

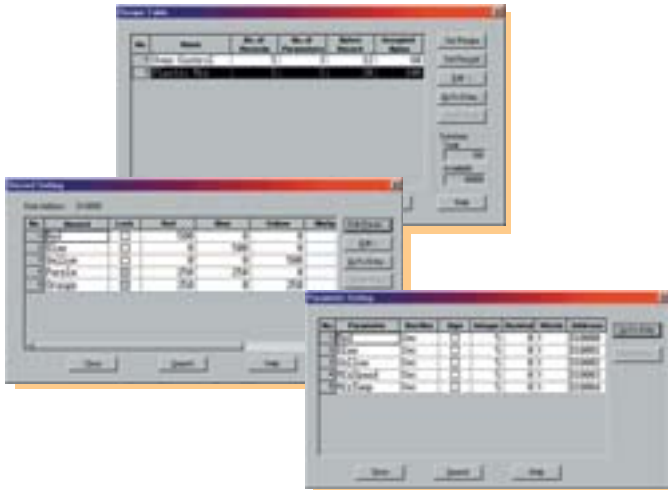
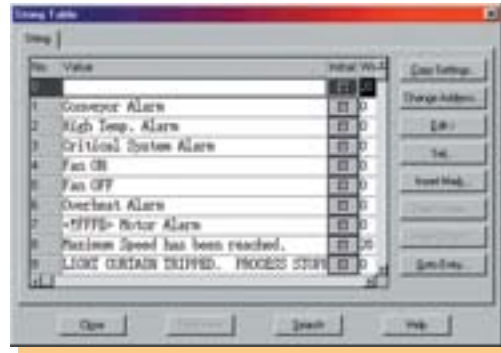

Recipe Table

The recipe table lets the programmer handle many functions:

- Create recipes
- Manage data for recipe objects
- Import and export data to/from the recipe table to a comma separated variable (CSV) file for future reference
- Limit operator access to making changes in recipe parameters
- Choose the link to the PLC data memory
- Configure how data will be displayed for the operator.

The recipe table manages up to 40K bytes of recipe memory.

Math Table

Store customized math equations and Boolean logic in the math table. Use it to process results from PLC data memory or references to the Numeral Table of NT terminals and constant values. Results can go to PLC data memory or the NT's Numeral Table. The math table can convert results into engineering units, scaling the value for display purposes. This eliminates the need for creating math in the PLC that can slow down processing.

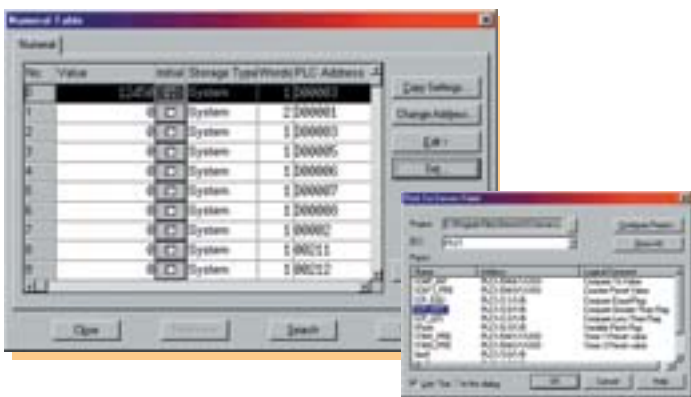
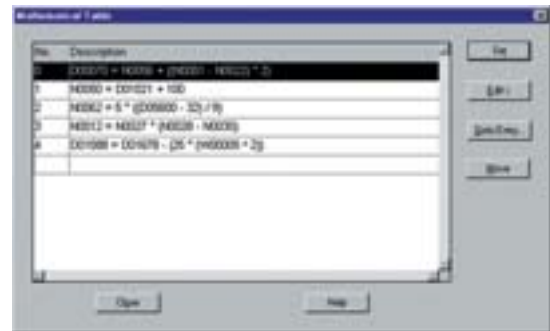

Numeral Table

All screen objects with numbers refer to this table to link back to the PLC memory area. Use the numeral table to organize data and establish initial or default values and format. This table references PLC memory locations to define constant values such as initial set point for timers, counters and temperature controllers. Subsequent data from the PLC resets and updates these values. Models NT21/31/631 allow the numeral table to be increased in size from 512 (default) to 1000 or 2000 entries. Larger numeral tables consume NT memory resources.

NT-Series

High Function Touch Screens NT21 / NT31 / NT631	14 - 21
Basic Function Touch Screens NT20S / NT600S	22 - 25
Large Function Key Unit NT11S	26 - 29
Small Function Key Units NT2S	30 - 33

Give your operators real-time information to control plant floor action using Omron's operator interfaces. Our full line includes small function-key units with flexibility to display critical messages, monitor bit status or enter numeric values. Touch screen models for more demanding applications deliver a wide range of capabilities including trending, alarm history storage, recipes, background math calculations, and input object lockout. Pair up Omron's space-saving operator interfaces with PLCs from Omron, other manufacturers, PC-based control boards, and DeviceNet networks. Omron has the right HMI for your needs.

Software

NT21/31/631

NT20S/600S

NT1TS

NT2S

Technical Highlights

Get the Most from Your Omron PLCs

The NT21/NT31/NT631 operator interface products create superior Omron PLC solutions by taking advantage of features that other HMI products simply cannot offer in an Omron system. Our HMI products are designed with the same attention to quality and performance that go into our broad line of industry leading PLCs. Omron's NT21/31/631 also offer significant programming flexibility in object layout and PLC controls, allowing you to create the program needed to realize your operator interface vision.

- **High-Speed NT Link** - This 115 kbaud serial Omron protocol allows rapid data exchange with Omron CJ1 and CS1 PLCs.
- **NT Link 1:N** - At 38.4 and 115 kbaud, NT Link 1:N allows 8 screens to be connected to a single serial port on CJ1 and CS1 PLCs with minimal impact to performance.
- **PLC Programming Console** - Simulate a hand-held programming device right on the HMI screen and monitor, set PLC values, and make minor ladder program changes.
- **PLC Device Monitor** - This function allows the NT31 and NT631 to function as watch windows, where the user can specify and view banks of PLC addresses, change values, and view errors without opening the panel.
- **Pop-Up Windows** - Present up to two pop-up windows at a time on the HMI screen to control critical information in a timely manner.
- **Window Control Area** - Control pop-up windows from the PLC memory by manipulating the window control area.
- **Parent/Child Windows** - Create screen segments that can be used again and again throughout a project. This conserves both screen memory and programming effort.
- Same programming functionality available in 5.2", 5.7", 10.4", and 11.3" screen sizes.
- DeviceNet communication module available for NT31 and NT631.
- Supports multi-vendor communication, allowing Omron touch screens to be the standard HMI.
- Memory module can be set to automatically upload or download both screen data and system firmware.
- Analog data can be displayed in chart, bar graph, and needle gauge objects.
- Binary status can be shown with lamps, animated bitmaps, and alarm bits.



Multi-Vendor Communications

Standardize on Omron's high quality touch screens regardless of which PLC vendors you use. Our drivers and vendor-specific cables allow Omron's NT31 and NT631 touch screens to communicate with the PLCs from the following vendors:

- Omron (CV, CS1, CJ1, CPM1A, CPM2□, SRM1)
- Allen-Bradley (ML1000/1200/1500, SLC 5/00, 5/01, 5/02, 5/03, 5/04, 5/05)
- GE Fanuc Series 90-20 and 90-30 PLCs
- Mitsubishi A and FX series PLCs
- Siemens S7-300 and S7-400 PLCs
- Modicon Micro, Premium, Quantum, Momentum

High-Speed NT Link

High-speed NT Link highlights the advantages that come when you partner an Omron PLC with an Omron touch screen. Combine Omron's CS1-EV1 PLCs with NT21/31/631 to benefit from 115k baud serial communications tailored exclusively for PLC to touch screen data. It is almost twice as fast as Host Link and 25% faster than standard NT Link when a single NT unit is connected to a PLC serial port. High-speed NT Link is three times faster than standard NT Link with 8 NT units connected to a single CS1 or CJ1 serial port.

OMRON Data Comparison

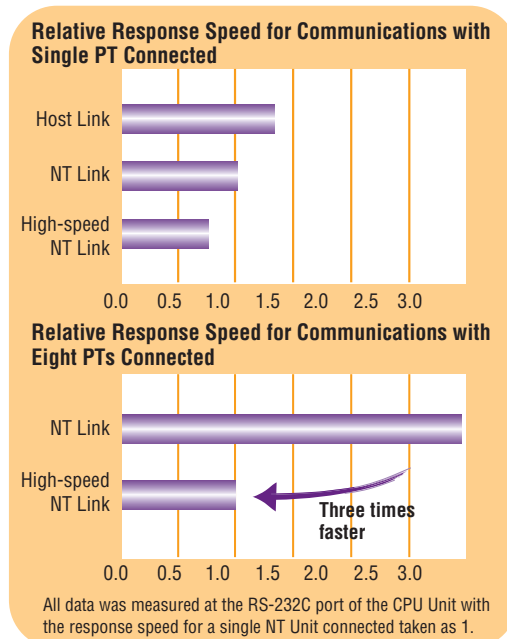

DeviceNet

The NT31 and NT631 can be quickly configured for DeviceNet communications, integrating seamlessly into your open DeviceNet network. This is truly a multi-vendor PLC solution, since no modifications need to be made to the screen data when changing the brand of the DeviceNet master. (See the DeviceNet Technical Discussion in the Technical Highlights of this catalog for detailed specifications.)



NT Link 1:N Communication

This protocol allows multiple interfaces to be connected to one PLC communication port. It is available with both standard and high speed NT Link. This protocol allows you to create a multi-drop system that puts up-to-the-second data at locations along the production line. (See the NT Link section in the Technical Highlights of this catalog for more details and specifications.)

Memory Link

Directly connect the NT with a single board computer, PLC or personal computer via RS-232C or RS-422 communications using Memory Link. This protocol allocates a virtual memory area within the operator interface to store data values. The screen program references this internal memory area for all screen objects, just as though this memory area belonged to a PLC. This means your PC based device only has to be concerned with referencing this memory area to read and write data values. (See the Memory Link section in the Technical Highlights at the end of this catalog for more details.)

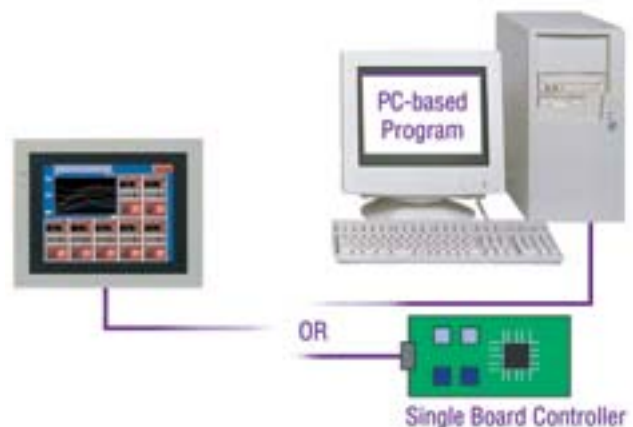

Recipe Data

Recipes store rows of values within the NT memory and operators can send that information down to the PLC to configure it for a batch operation. The new Recipe Table editor in NTST v4.6 creates and manages recipe information, allowing recipe data to be up- or downloaded from the NT hardware. NTST can also work with comma separated variable files to read in large recipe tables, or store uploaded recipe data for future reference or use.

No.	Cake	Cream	Sugar	Egg	Milk
1	Cheese cake	1000	200	20	200
2	Almond cake	500	200	10	250
3	Fondant cake	1000	200	10	200
4	Carrot cake	500	150	10	250
5	Butter cake	700	150	20	300
6	Apple cake	500	200	5	200
7	Banana cake	500	200	10	150
8	Layer cake	1000	450	10	300
9	Cream cake	1000	200	15	100
10	Chocolate cake	0	0	0	0

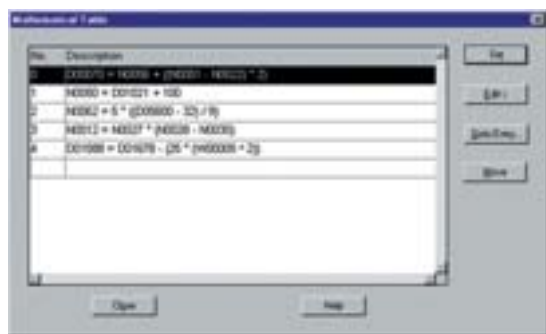

Background Math Function

NT31/631 units store a Mathematical Table that allows functions of different formats to run in the background of the NT31/631 units. The equations can be constructed of constants, values from NT31/631 memory, or values from PLC memory locations. Calculation results can be sent to NT31/631 internal memory or directly to the PLC memory. Now you can convert values for display purposes within the display device, leaving the PLC to worry about calculations that affect your process.

Input Enable - Bit Interlock Function

This function is suited for use as a password protection function. The interlock function denies access to input objects (touch switches, thumb-wheels, numeric input fields, and string input fields) based on the status of a bit in the PLC. Each input object within an NT31/631-EV2 project can be assigned to a unique bit or the same bit within the PLC. If the bit is ON, the input object will function. Turn the bit OFF and the input object is locked out. An excellent application of this feature would be login security. When the operator enters a password using a keypad, the PLC will compare the entered number to the values in certain PLC memory registers. The PLC can then change the referenced bits from 0 to 1 accordingly, granting access to different screen areas or input objects as designated by the user's access level.



Pop-Up Windows

Two window screens can be displayed in one standard screen, maximizing screen space and application efficiency. All objects (except thumb-wheel switches) can be displayed within these pop-up windows allowing operators to simultaneously view different aspects of the process as needed. Create a variety of pop-up window screens and call them up for display in your application as needed, either manually or from PLC memory.



Memory Unit

This portable FLASH memory module includes two 1MB banks. Each bank can store the screen data from a fully loaded operator interface, or the firmware program for the NT21, NT31 or NT631. The module can be set for manual or automatically triggered upload or download of data. In fact, the module can be configured to first download a new firmware program and then to automatically download new screen data. Imagine how easy it would be to update customers in the field! No PC connection is needed. Just plug on the module, power up the touch screen and transfer the programs.

Alarm History, Frequency, and Activity

Track your process and create a fault record using the alarm history, frequency and activity functions. These pop-up windows graphically convey problems in your process and allow you to make corrections to save time and materials. Simply drag the alarm object into the touch screen project, create a PLC bit reference in an alarm bit table, add a message to that bit, and the NT21/NT31/NT631 are ready to track and report alarms. The complete alarm history and frequency reports can be printed from the system menus.



Programming Console

When using an Omron PLC and NT-Link communications, this feature allows you to adjust mnemonic programming and access, monitor, and change individual memory addresses using the operator interface instead of a laptop or hand-held programmer. Now, maintenance personnel no longer need to carry a hand-held programmer or laptop from PLC to PLC to perform diagnostics. It can be performed right from the front of the operator interface without ever opening the control panel.

Device Monitor Function

Another feature available on the NT31/631 when using an Omron PLC, the Device Monitor Function allows the NT to monitor tables of individually selected PLC values, or entire ranges of a PLC memory area. Once the values or ranges are selected, data values can be viewed in real time as they change. There is also a window to view errors currently active within PLC memory. Previously, only the PLC programming software could perform these diagnostics. Now, no laptop is needed for these basic debugging tools.

Registration Monitor – Manually create a list of PLC addresses and simultaneously monitor them. Update the different values by touching the address and entering a new value with a popup keypad.

PLC Error Screen – View the current errors in the PLC.

Continuous Monitor - Create a table of 50 PLC addresses to monitor and change. Simply select the initial address, and the table automatically fills in with the next (25 for NT31, 50 for NT631) sequential addresses.



Images and Art Objects

Bitmap images can be displayed as fixed objects or image lamps. Image lamps have an ON state and OFF state, each represented by a different bitmap. Image objects display bitmap images from the image table stored within the operator interface. This can be a fixed reference to one image table location, or the reference can be controlled by the PLC. This is an excellent way to quickly achieve animation.

Touch Switches and Lamps

The original purpose of touch screens was to provide a cost effective replacement for hardwired pushbutton and selection switches and indicator lamps. This is still one of the primary motivations on panels today. The NT31 and NT631 include a variety of touch switch and lamps, as well as a library of image objects to lend that special touch. Omron touch switches and lamps include a higher degree of control than most touch screen products, allowing the objects to be sized, colored, and positioned as needed. There are also many labeling options available:

- Control bits
- Control pop-up windows
- Switch screens
- Copy values
- Input numeric & text characters
- Move the cursor
- Execute a screen print



Dynamic Labels

The labels within touch switches and lamps can change with bit state, display a numeric value from PLC memory, or display any number of messages directly from a string table as commanded by the PLC. The string table is a numbered list where each table entry represents a different string message. The PLC can specify a string table entry number and change the message displayed within a switch or lamp, creating a great deal of application flexibility.

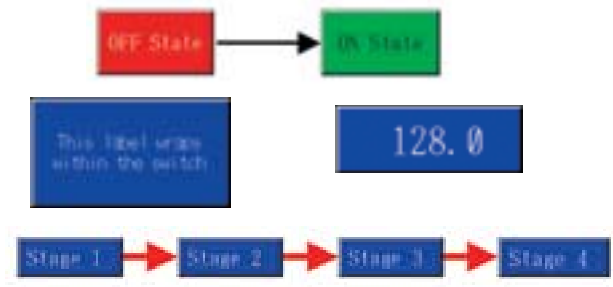

Numeric and String Display

Numeric values can be displayed as bar graphs, needle meters, or simple formatted numerals. All of these options are highly customizable, and can be located anywhere on the screen. Strings can be displayed as alphanumeric characters read from the string table in the operator interface memory as directed by the PLC, or taken directly from PLC memory.

Graphical Data Display

Use colorful charts and graphs to convey complex data to your operators at a glance. Chart data can be logged for review of previous activity.

Communication Ports

The NT31 and NT631 series interfaces have a dedicated printer port, an RS-232C port with a 5vdc pin, and a port that is configured to RS-232C, RS-422/485 (the NT631 uses a terminal block for RS-422/485 connection). The dedicated RS-232C port is generally left available to ensure a free port for program transfer. The dedicated RS-232C port is also available for connection to a bar-code reader (Omron serial driver only). The NT21 series interface has two RS-232C ports. One port can be converted to RS-422/485 using the NS-AL002 adapter.



NT21



NT31



NT631



NT21



NT31



NT631

Compact Design

The shallow depths, efficient face dimensions, and small panel cutout requirements make this NT series ideal for mounting in confined spaces.

Ordering Information

Description	Part Number
NT21 Display	
Monochrome STN LCD 5.2" touch screen	NT21-ST121□-E
NT21 Accessories	
5 NT21 Protective Screen Sheets	NT20M-KBA04
NT21 Chemical Resistant Cover	NT20S-KBA01
RS232C to RS422A Adapter	NS-AL002
NT31 Display	
Monochrome STN LCD 5.7" touch screen	NT31-ST121□-EV2
8 Color STN LCD 5.7" touch screen	NT31C-ST141□-EV2
NT31 Accessories	
NT30/NT31 Chemical Resistant Cover	NT30-KBA01
5 NT30/NT31 Protective Screen Sheets	NT30-KBA04
NT31/NT31C Replacement Backlight	NT31C-CFL01
50 cm 25-9PIN Cable, NT to Omron PLC	NT31C-CN510-EU
3 m 25-9PIN Cable, NT to Omron PLC	NT31C-CN320-EU
5 m 25-9PIN Cable, NT to Omron PLC	NT31C-CN520-EU
3 m 25-9PIN Cable, NT to AB PLC	NT31C-CN321-EU
3 m 25-9PIN Cable, NT to GE PLC	NT31C-CN322-EU
3 m 25-9PIN Cable, NT to Siemens	NT31C-CN323-EU
3 m 25-9PIN Cable, NT to Mitsu-A	NT31C-CN324-EU
3 m 25-9PIN Cable, NT to Mitsu-FX	NT31C-CN325-EU

Description	Part Number
NT631 Display	
Electroluminescent 10.4" touch screen	NT631-ST211□-EV2
8 Color STN LCD 11.3" touch screen	NT631C-ST141□-EV2
8 Color TFT LCD 10.4" touch screen	NT631C-ST151□-EV2
NT631 Accessories	
NT631C-ST141 Replacement Backlight	NT631C-CFL01
NT631C-ST151 Replacement Backlight	NT631C-CFL02
NT631 Chemical Resistant Cover	NT625-KBA01
5 NT631 Protective Screen Sheets	NT610C-KBA04
General Accessories	
NT Series Support Tool v 4.6	NT-ZJCAT1-EV4
Programming Cable 9-9 pin	C200H-CN229-EU
50 cm 9-9PIN Cable, NT to Omron PLC	C200H-CN510-EU
3 m 9-9PIN Cable, NT to Omron PLC	C200H-CN320-EU
5 m 9-9PIN Cable, NT to Omron PLC	C200H-CN520-EU
2 m 9PIN Cable, NT to AB DH-485 Port	NT631C-CN221-485
3 m 9-9PIN Cable, NT to AB PLC	NT631C-CN321-EU
3 m 9-9PIN Cable, NT to GE PLC	NT631C-CN322-EU
3 m 9-9PIN Cable, NT to Siemens	NT631C-CN323-EU
3 m 9-9PIN Cable, NT to Mitsu-A	NT631C-CN324-EU
3 m Term-25PIN Cable, NT to Mitsu-FX	NT631C-CN325-EU
2 m CS1/CJ1/CPM2C Peripheral Com. Cable	XW2Z-200T-2
5 m CS1/CJ1/CPM2C Peripheral Com. Cable	XW2Z-500T-2
NT to Printer Cable	NT-CNT121
NT31/NT631 Program Transfer Module	NT-MF261
30W, 24 VDC, 1.3 A Power Supply	S82K-03024
50W, 24 VDC, 2.1 A Power Supply	S82K-05024
Operation Manuals	
NT21 Set-Up Manual	V068-E1-1
NT31 Set-Up Manual	V062-E1-1
NT631 Set-Up Manual	V063-E1-1
NT21/31/631 Reference Manual	V069-E1-1

NT21 Dimensions

mm (inches)

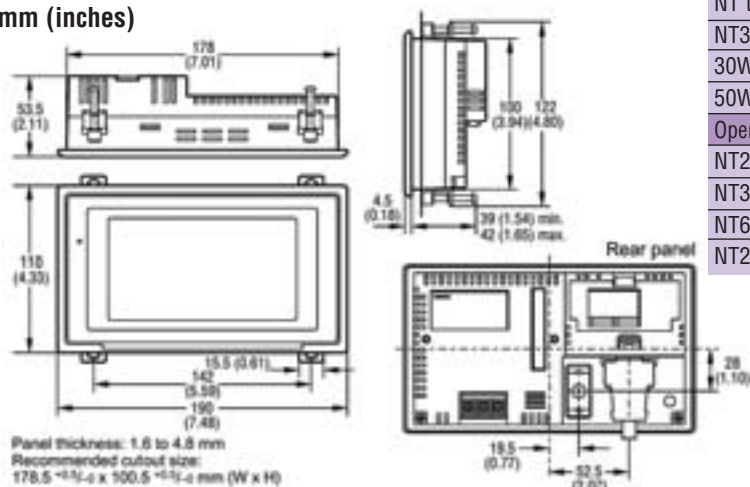

NT31 Dimensions

mm (inches)

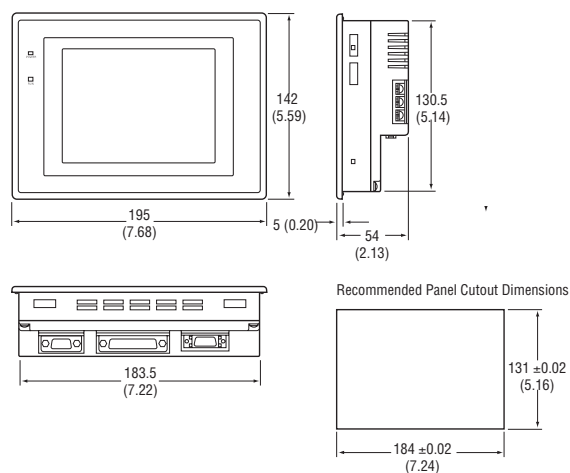

NT631 Dimensions

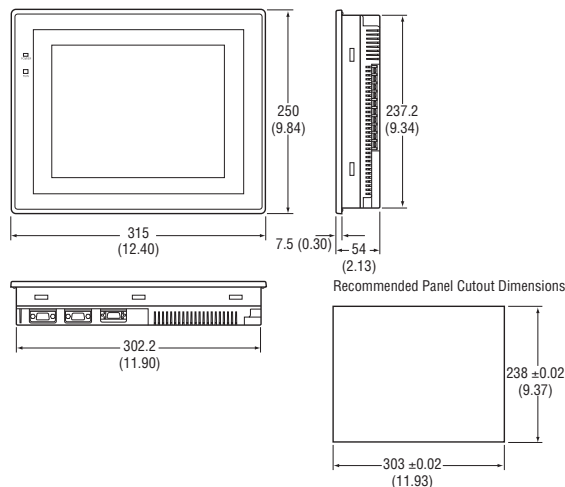

Software

NT21/31/631

NT20S/600S

NT11S

NT2S

Technical Highlights

Specifications

	NT21	NT31/31C	NT631/631C
Rated power supply voltage	24 VDC		
Power consumption	7 W max.	15 W max.	ST211□ 30 W max.; ST141□ & ST151□ 18 W max.
Operating ambient temperature	0 to +50°C (with no icing)	0 to +50°C	ST211□ & ST151□ 0 to +50°C; ST141□: 0 to +40°C
Operating ambient humidity	35 to 85% (0 to 40°C) 35 to 60% (40 to 50°C) (with no condensation)	35% to 85% (with no condensation)	
Noise resistance	Conforms to IEC61000-4-4; Power supply line: 2 kV	Common mode: 1000 Vp-p (between power supply terminals & panel); Normal mode: 300 Vp-p; Pulse width of 100 ns to 1 μs, pulse rise time of 1 ns	
Vibration resistance (operating)	10 to 57 Hz with 0.075 mm amplitude; 57 to 150 Hz with 1G (9.8 m/s ²) acceleration for 60 min. in each of X, Y, Z directions	10 to 57 Hz with 0.075 mm amplitude; 57 to 150 Hz with 1G (9.8 m/s ²) acceleration for 60 min. in each of X, Y, Z directions	ST211□: 10 to 57 Hz with 0.075 mm amplitude for 30 min. in each of X, Y, Z directions; ST141□ & ST151□: 10 to 57 Hz with 0.075 mm amplitude, 57 to 150 Hz with 1G (9.8 m/s ²) acceleration for 30 min. in each of X, Y, Z directions
Shock resistance (operating)	147 m/s ² (15G); 3 times in each of X, Y, Z directions		
Dimensions	190 (W) x 110 (H) x 53.5 (D) mm (thickness inside panel: 49 mm)	195 (W) x 142 (H) x 54 (D) mm (w/ expansion unit: 74 D)	315 (W) x 250 (H) x 54 (D) mm (w/ expansion unit: 74 D)
Weight	0.6 kg max.	1 kg max.	2.5 kg max.
Enclosure ratings	Front panel: equivalent to IP65F (NEMA4)*		
Display panel		Monochrome or Color STN LCD with backlight	ST211□: EL (monochrome); ST141□: Color STN LCD with backlight; ST151□: Color TFT LCD with backlight
Number of dots (resolution)	260 dots horizontally x 140 dots vertically	320 dots horizontally x 240 dots vertically	640 dots horizontally x 480 dots vertically
Effective display area	117 (H) x 63 (V) mm (5.2 inches diagonal)	118.2 (H) x 89.4 (V) mm (5.7 inches diagonal)	ST211□ & ST151□: 211 (H) x 158 (V) mm (10.4 inches diagonal) ST141□: 229 (H) x 172 (V) mm (11.3 inches diagonal)
View angle	Left/right direction: 30°; Up/down: 30°	NT31: Up: 20, Down: 30, Left/right: 30; NT31C: Up: 45, Down: 60, Left/right: 50	ST211□: No restriction; ST141□: Up/down: 30, Left: 55, Right: 45; ST151□: Up: 40, Down: 55, Left/right: 55
Display color	ST121□: 2 color black/white	ST121□: 2 color black/white; ST141□: 8 color	ST211□: 2 color black/gold; ST141□ & ST151□: 8 color
Life expectancy	50,000 hours minimum	50,000 hours minimum	ST211□: 30,000 hrs min.; ST141□ & ST151□: 50,000 hrs min.
Contrast adjustment	Knob on back of unit	NT31 & NT631-ST141□ only: Adj. in 100 levels by touch switch operation at panel	
Max. number of registered screens	3999 screens		
Backlight			
Life expectancy	50,000 hours min.	25,000 hours min.	ST141□: 25,000 hours min.; ST151□: 30,000 hours min.
Replacement	Non-replaceable	NT31, NT631-ST141□ & NT631-ST151□: Can be replaced from the rear	
Brightness adjustment	–	NT31 & NT631-ST141□ only: Adj. in 3 levels by operation at the touch panel	
Automatic turn-off function	Can be set to turn off in 1 to 255 minutes, or to remain on with screen saver		
Touch panel			
Type	Resistive type		
Number of switches	91 (13 horizontally x 7 vertically)	192 (16 horizontally x 12 vertically)	768 (32 horizontally x 24 vertically)
Max. number registered on one screen	91	192	256
Life expectancy	One million operations minimum		
Serial communication			
Serial port A	Conforms to EIA RS-232C; D-SUB 9-pin connector (female); +5 V (250 mA max.) output at pin No. 6		
Serial port B	Conforms to EIA RS-232C; D-SUB 9-pin connector (female); +5 V (250 mA max.) output at pin No. 6	EIA RS-232C or RS-422A/485 (selectable, by memory switch setting); D-SUB 25-pin connector (female)	EIA RS-232C (serial port B terminal block selectable by memory switch setting); D-SUB 9-pin connector (female)
Serial port B terminal	–	–	EIA RS-422A/485 (serial port B connector selectable by memory switch setting); Terminal block
Battery backup	Numeral/character string memory tables data in the NT unit; Alarm history data table in the NT unit; Recipe tables in the NT unit; Real time clock and calendar (NT31/31C/631/631C only)		
Screen print function	–	"ESC/P", "Color": Color printing conforming to ESC/P 24-J83C; "PC-PR201H", "Color": Color printing conforming to PC-PR201PL; "ESC/P", "Tone": Monochrome printing in 8 grayscale levels, conforming to ESC/P 24-J82; "PC-PR201H", "Tone": Monochrome printing in 8 grayscale levels, conforming to PC-PR201PL; "PCL-5", "Tone": Monochrome printing in 8 grayscale levels, conforming to PCL 5; however, the NT31 & NT631 supports monochrome printing only	
Calendar & clock function	–	Displays the current time in accordance with the built-in clock; Displayed and set with "Calendar Check" in the MAINTENANCE MODE" menu	

Software

NT21/31/631

T20S/60S

NT1S

NT2S

Technical Highlights

NT20S

- 5" Monochrome LCD w/Blue pixels
- 5" Monochrome LCD w/Black pixels
- 256x128 pixel resolution
- 72 touch cells per screen
- 96 K program memory
- 500 screen capacity
- Field replaceable backlight
- 54 mm (2.1") panel depth
- Ratings: UL/CE/GSA, NEMA 4

NT600S

- 9" Monochrome LCD w/Blue pixels
- 9" Electroluminescent Display
- 640x400 pixel resolution
- 128 touch cells per screen
- 128 K program memory
- 500 screen capacity
- Field replaceable backlight
- Ratings: UL/CE/GSA, NEMA 4

The NT20S and NT600S operator interfaces provide basic touch screen functionality in compact, low-cost packages providing the basic elements required for control. These elements include touch switches, lamps, numeric and string displays, bar graphs, numeric keypads, and thumb-wheels. Screen programs are created in a graphical drag-and-drop environment using the NT-Series Support Tool (NTST).



NT600S



NT20S

Field Replaceable Backlight

Minimize downtime and reduce cost of ownership with the NT20S and NT600S field replaceable backlights. Open the control panel, remove one screw and pull out the backlight unit. It is as simple as that. There is no need to remove the NT unit from the panel for servicing. Service the backlight right there on the spot.

Touch Switches and Lamps

Create touch switches that are as small as the actual touch cell, or as large as the entire screen. Shadow effect can be added to a touch switch. Lamps can be set to any size on the screen. Square or circular lamps can be created. Added text to both touch switch and lamp objects.



Static Screen Text

Choose from a variety of different font sizes. Display the text as an inverse image. Flash the text to draw attention to a message. Select different ratios of text height to width.

Keypad Numeric Input

Enter numeric values into PLC data memory areas. Specify the data memory area in the NTST numeral table. Thumb-wheel object mimics the input of a traditional thumb-wheel device. Default numeric entry keypad automatically appears at the bottom of the screen. It can input values to multiple numeric fields. Set high and low limits for each numeric input.



Numeric and String Display

Use standard numeric display to show number value. String display field can display ASCII message strings from the PLC memory.

Bar Graphs

Bar graphs can display numeric values graphically. Set the max. value of the bar graph so that a full bar graph conveys the proper message for the process. Resize the bar graphs and display in horizontal and vertical orientations. Configure bar graphs to fill up, down, left, or right.

Communication Options

Connect the NT20S and NT600S to a PLC using Host Link, NT Link 1:1, and NT Link 1:N to a custom controller using a Serial Link protocol. Protocols are designed for high-speed operation, updating bit, numeric, and string data immediately for display or control purposes. Fast updates and quick response times are guaranteed.

NT Link 1:1

NT Link, an Omron proprietary protocol, is optimized to provide fast and reliable communication between a single NT unit and PLC. Omron uses a 9-pin RS-232C serial cable to connect one NT to a PLC serial port, referred to as a 1:1 connection. It is possible to connect multiple screens to multiple serial ports on the same PLC using 1:1 connections as shown to the right.

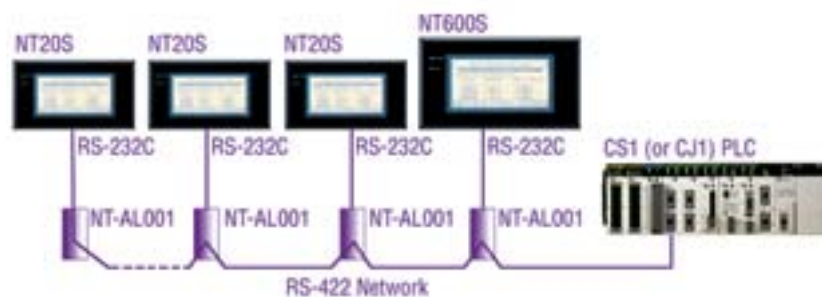

NT Link 1:N

The NT Link protocol can also be used to connect multiple touch screens to a single PLC serial port. Eight screens can be connected to a single serial port on the PLC, reducing the need for additional PLCs or serial port modules. NT Link 1:N provides extremely fast operation even with 4 screens communicating simultaneously over an RS-422A network. The diagram highlights how NT20S and NT600S units can be connected using NT Link 1:N. (See the NT Link section in Technical Highlights for more detailed information.)

Serial Link

The NT20S-ST128 is designed to communicate with the serial port of any custom controller programmed in Visual Basic, C, C++, etc. It is an excellent fit for a custom built solutions that require rugged, industrial operator interfaces. The serial device sends and receives data from the NT20S using a special ASCII commands set. Once the serial device's program is complete, the NT20S can be customized quickly to meet new customer demands.

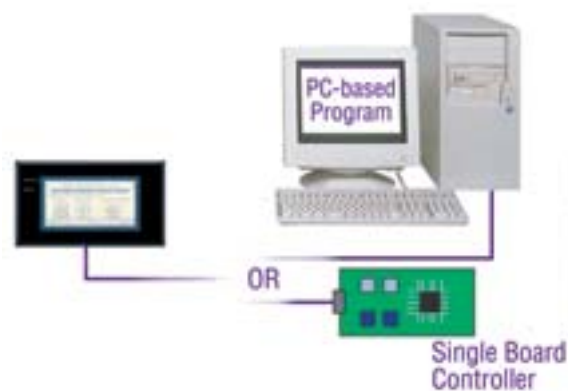

Ordering Information

Description	Part Number
NT20S Display	
Blue LCD 5" backlit touch screen - ivory	NT20S-ST121-EV3
Blue LCD 5" backlit touch screen - black	NT20S-ST121B-EV3
Black LCD 5" backlit touch screen - ivory	NT20S-ST161-EV3
Black LCD 5" backlit touch screen - black	NT20S-ST161B-EV3
Blue LCD 5" touch screen - serial link - black	NT20S-ST128B
NT20S Accessories	
Chemical Resistant Cover	NT20S-KBA01
Protective Screen Sheets	NT20M-KBA04
Backlight	NT20S-CFL01
NT600S Display	
9" LCD touch screen - ivory	NT600S-ST121-EV3
9" LCD touch screen - black	NT600S-ST121B-EV3
9" Electroluminescent touch screen - ivory	NT600S-ST211-EV3
9" Electroluminescent touch screen - black	NT600S-ST211B-EV3

Description	Part Number
NT600S Accessories	
Chemical Resistant Cover	NT600S-KBA01
Protective Screen Sheets	NT600M-KBA04
Backlight	NT600S-CFL01
Battery	3G2A9-BAT08
General Accessories	
NT Series Support Tool v 4.6	NT-ZJCAT1-EV4
Programming Cable 9-9 pin	C200H-CN229-EU
50 cm 9-9PIN Cable, NT to PLC	C200H-CN510-EU
3 m 9-9PIN Cable, NT to PLC	C200H-CN320-EU
5 m 9-9PIN Cable, NT to PLC	C200H-CN520-EU
2 m CS1/CJ1/C2PMC Peripheral Com Cable	XW2Z-200T-2
5 m CS1/CJ1/C2PMC Peripheral Com Cable	XW2Z-500T-2
RS232/422 Converter	NT-AL001
Operation Manuals	
NT20S Operation Manual	V020-E3-1
NT600S Operation Manual	V022-E3-1

Specifications

	NT20S	NT600S
Rated power supply voltage	24 VDC	
Power consumption	10 W max.	ST121: 24V, less than 15 W; ST211: 24V, less than 25 W
Operating ambient temperature	0 to +50°C (with no freezing)	
Operating ambient humidity	35% to 85% RH (with no condensation)	
Resistance to electrostatic discharge	Level 3 (IEC801-2); In air ±8 kV, contact ±6 kV, indirect ±7 kV	
Electromagnetic field strength	10 V/m (IEC801-3)	
Fast transient/burst noise	Power supply line: 2 kV (IEC801-4); I/O line: 0.25 kV	
Damped oscillatory wave	Power supply line: 1 kV (IEC255-4)	
Vibration resistance	10 to 22 Hz with 1.5 mm double amplitude for a total of 30 min. in X, Y, Z directions; 22 to 500 Hz with 1.5 G (14.7 m/s ²) acceleration in X, Y, Z directions	
Shock resistance	Durability: 30 G, 3 times each in X, Y, Z directions; Malfunction: 20 G, 3 times each in X, Y, Z directions	
Dimensions	190 (W) x 110 (H) x 58 (D) mm	275 (W) x 192 (H) x 71 (D) mm
Weight	0.7 kg max.	1.8 kg max.
Enclosure ratings	Front panel: equivalent to IP65 (front face waterproof construction)	
Display panel	STN Liquid Crystal Display (LCD) with backlight	
	EL (monochrome) or Color STN LCD with backlight	
Number of dots (resolution)	256 dots horizontally x 128 dots vertically	640 dots horizontally x 400 dots vertically
Effective display area	Blue mode (ST121□): 112 mm horizontally x 56 mm vertically; Monochrome mode (ST161□): 5 inches diagonal	192 mm horizontally x 120 mm vertically
View angle	Left/right direction: ±35°	STN: Left: 50°, Right: 40°; EL: Left/right: 80°
Life expectancy	50,000 hours minimum	STN: 50,000 hrs min.; EL: 30,000 hrs min. (till brightness becomes 30% weaker)
Max. number of registered screens	495	1000 max.
Backlight		
Life expectancy	10,000 hours minimum (average: 20,000 hours)*1	STN: average: 20,000 hours (the time taken for the brightness to decline to half its original value at normal temperature and humidity)
Touch panel		
Number of switches	Max. 72 registerable per screen (12 horizontally x 6 vertically)	
Life expectancy	One million operations minimum	
Serial communication		
Serial port	EIA RS-232C; 9-pin, D-SUB connector (female)	

*1: This is the time it takes for the brightness to decline half its original value under normal temperature and humidity conditions.

NT20S Dimensions

mm (inches)

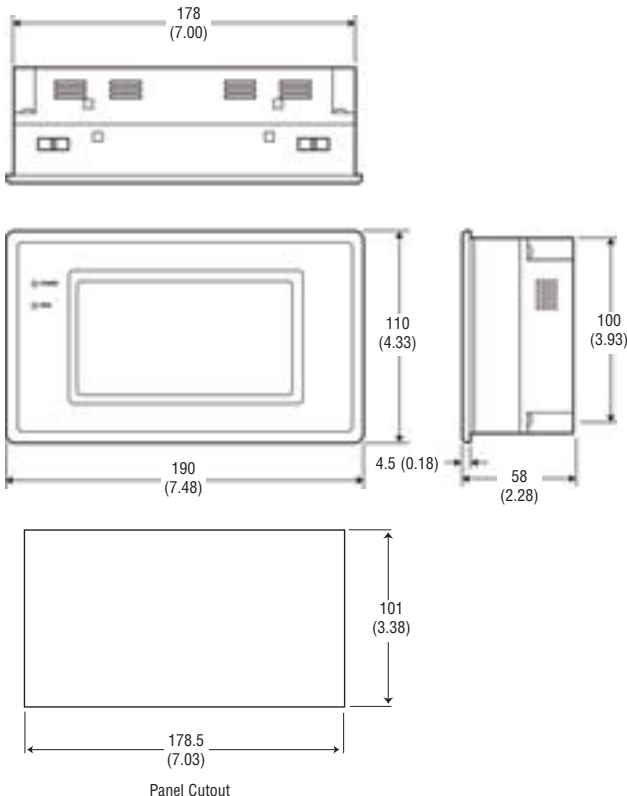

NT600S Dimensions

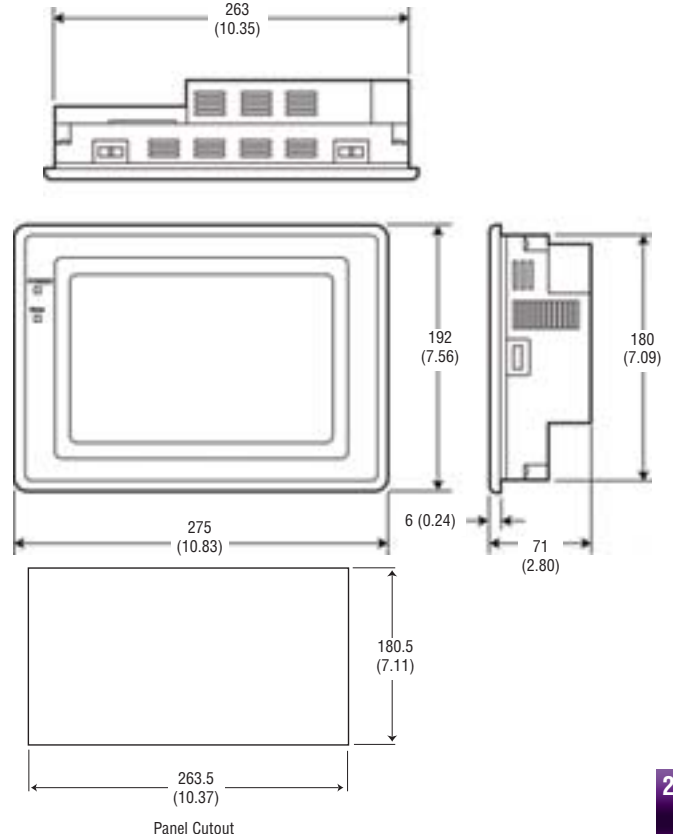

Large Function Key Unit - NT11S

Software

- Large characters
- 4 line x 20 character backlit LCD
- 32 K memory (up to 250 screens)
- 4 global programmable function keys
- Bar graph capability
- Password protect screens
- Printer port
- Host link/NT link communication
- Contrast control
- NEMA 4
- Black of ivory front bezel

NT11/31/631

NT203/600S

NT11S

NT2S

Technical Highlights

Omron's NT11S alphanumeric 4 line x 20 character operator interface is a flexible keypad unit for applications requiring function key control. Compact and easy to operate, this full-featured operator interface allows accurate monitoring and controlling, and includes slide-in legend for custom labeling of function keys. The extra-large keys on the numeric keypad provide operators the tactile feedback for quick data input or screen change, even when wearing thick work gloves. And the LED backlight of the NT11S LCD presents data clearly even in brightly lit areas.



Menu-Based Screen Navigation

The NT11S screens are navigated from the keypad using a menu driven system. The operator views a menu of options and selects a number from 1 to 4 to change to that screen. NTST software makes it easy to set up and the clear screen and large function keys make it easy to operate.

Password Protected Screens

A password can be assigned that will protect any individual screen change. A password request can be inserted following any menu screen selection, limiting access to sensitive application information. Without a password request, users are free to gain access to any menu selection.



Numeric and String Display

Data displayed on the NT11S screen comes directly from PLC memory for both numeric and string displays. The numeric values can appear as numerals or bar graphs. Strings are displayed and read as ASCII from PLC memory and displayed in alphanumeric fields. These objects can be dragged from the control object toolbar within NTST, allowing critical data to be arranged quickly and clearly.

Numeric Input

The NT11S keypad is the default input mechanism for any numeric input field programmed on the NT11S. Simply drag a numeric input field onto the NT11S screen within NTST and use the keypad to input and enter values.



Sizeable and Inverse Text

The NT11S is considered a 4 line x 20 character display. However, the NT11S allows characters to be created that are 2 lines tall, for attention grabbing critical data. The NT11S screen can mix different sized text characters to help you get your point across.



NT Link 1:1

NT Link, an Omron proprietary protocol, is optimized to provide fast and reliable communication between a single NT unit and PLC. Omron uses a 9-pin RS-232C serial cable to connect one NT to a PLC serial port, referred to as a 1:1 connection. It is possible to connect multiple screens to multiple serial ports on the same PLC using 1:1 connections as shown to the right.

Ordering Information

Description	Part Number
NT11S Display	
4 x 20 Alphanumeric display - ivory	NT11S-SF121
4 x 20 Alphanumeric display - black	NT11S-SF121B
General Accessories	
NT Series Support Tool v 4.6	NT-ZJCAT1-EV4
Programming Cable 9-9 pin	C200H-CN229-EU
50 cm 9-9PIN Cable, NT to PLC	C200H-CN510-EU
3 m 9-9PIN Cable, NT to PLC	C200H-CN320-EU
5 m 9-9PIN Cable, NT to PLC	C200H-CN520-EU
2 m CS1/CJ1/C2PMC Peripheral Com Cable	XW2Z-200T-2
5 m CS1/CJ1/C2PMC Peripheral Com Cable	XW2Z-500T-2
Operation Manuals	
NT11S Operation Manual	V029-E1-1

Specifications

NT11S	
Rated power supply voltage	24 VDC
Power consumption	Less than 10 W
Operating ambient temperature	0°C to 50°C (with no freezing)
Operating ambient humidity	35% to 85% RH with no condensation
Noise resistance	Common mode (between power supply & panel): 1000 Vp-p; Normal mode: 300 Vp-p; Pulse width: 100 ns to 1 μs; Pulse rise time: 1 ns
Vibration resistance (operating)	10 to 22 Hz with 1.5 mm double amplitude for a total of 30 minutes in X, Y, Z directions; 22 to 500 Hz with 1.5 G (14.7 m/s ²) acceleration in X, Y, Z directions
Shock resistance	Durability: 30 G, 3 time each in X, Y, Z directions; Malfunction: 20 G, 3 times each in X, Y, Z directions
Dimensions	218 (W) x 113 (H) x 38.2 (D) mm
Weight	1.0 kg max.
Enclosure ratings	Front panel: Equivalent to IP65 (front face waterproof construction)
Display panel	Dot matrix liquid crystal display (LCD) panel
Number of dots (resolution)	64 dots horizontally x 160 dots vertically
Effective display area	40 mm (H) x 100 mm (V)
View angle	Left direction: 35°; Right direction: 35°
Life expectancy	50,000 hours minimum
Backlight	
Life expectancy	50,000 hours minimum (guaranteed time: 30,000 hours)
Automatic turn-off	Can be set to turn off in 10 minutes or 1 hour, or to remain on
Switch	
Number of switches	22
Life expectancy	One million operations minimum
Max. number of registered screens	250
Communication standard serial port	EIA RS-232C; 9-pin D-SUB connector (male)
Printer port	25-pin D-SUB connector (female, Centronics)

NT11S Dimensions

mm (inches)

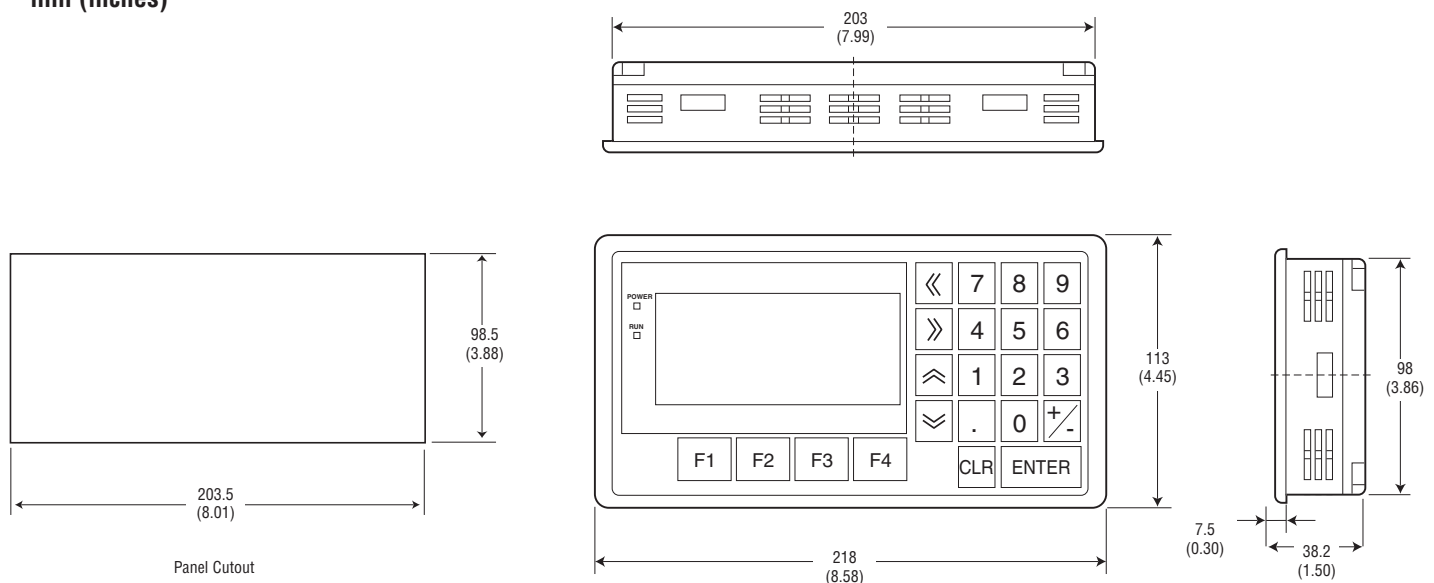

Small Function Key Units - NT2S

Software

NT21/31/631

NT20S/600S

NT11S

NT2S

Technical Highlights

- High visibility LED backlit LCD display shows 2 lines of 16 characters
- Choose programmable or message display models
- Compact, fits 1/8 DIN panel cutout
- Six programmable function keys
- Two programmable LED indicators
- Powered by peripheral port or 24 VDC power supply
- Password protect any function key
- Bar graph display
- UL, cCSAus, and CE approvals
- IP65 protection rating
- Programming software included at no cost



The NT2S series was designed to be a low-cost, high function operator interface for micro-PLC applications. Packed with features and easy to program, these small-sized function key units are perfect for accessing PLC data in cost sensitive, or space constrained applications. The compact NT2S 2-line interfaces offer a choice of models: an ASCII message display model and programmable models. The message display model receives ASCII and numeric information from the PLC registers, so no programming tool is needed. The programmable models store extensive custom screen programs within their internal memory, can send and receive information to and from a PLC, and handle scrolling messages up to 256 characters. The Windows® programming tool, distributed free of charge, uses a graphical programming environment to create screens as they will be displayed on the NT2S unit.

Model Selection Chart

Feature	NT2S-SF121B-E	NT2S-SF122B-E	NT2S-SF123B-E
NT2S programming software required	Yes	Yes	Displays ASCII and numeric data stored in the PLC
Omron PLC peripheral communications	Yes	Yes	Yes
PLC serial port communications	Yes	Yes	–
Real time clock	Yes	–	–
Powered by peripheral port	–	Yes	Yes
Powered by external 24 VDC	Yes	–	–
Omron PLC connection	Yes	Yes	Yes
Multi-vendor PLC connection	Yes	Yes	–
F-keys enter numeric data	Yes	Yes	Yes
Displays ASCII messages from PLC registers	–	–	Yes
PLC bit controlled text	Yes	Yes	–

NT2S-SF121B-EV2

Get a big value from this small package. The free Windows® based programming software allows users to design screens that simplify data entry and program function keys. The function keys can perform multiple tasks within a program. These units use 24 VDC, which makes this NT2S ideal for multi-vendor PLC applications. A real-time clock sends the year, month, date, hour, minute, and second information to user-specified PLC registers, enhancing many micro PLC applications. It is a great fit for multi-vendor PLC applications requiring a real-time clock.



NT2S-SF122B-EV2

Eliminate the operator interface power supply! This unit is powered directly from an Omron PLC peripheral port (5 VDC), through the communication cable, making for an extremely cost-effective way to integrate an operator interface to cost sensitive applications. This operator interface has display and data entry capabilities and utilizes the Windows® based software tool included with the unit.

NT2S-SF123B-EV2

Consolidate all project programming within the PLC, eliminating the need to maintain separate PLC and an HMI programs. Choose the NT2S-SF123B-EV2 for small applications requiring an operator interface that has message display, occasional numeric entry, and manual or PLC controlled screen changing capabilities. It eliminates a separate power supply by using 5 VDC from the PLC peripheral port through the communication cable. This little unit can even display bar graphs and formatted numeric displays. The 6 function keys can navigate to different PLC registers and adjust PLC numeric values. This is one very efficient design, only from Omron!



Software

NT2S/31/631

NT20S/60DS

NT11S

NT2S

Technical Highlights

NT2-Software Tool (NT2ST)

Program the NT2S-SF121B-EV2 and the NT2S-SF122B-EV2 in an easy-to-navigate, WYSIWYG windowed environment of NT2ST. Unlock the tremendous flexibility of the NT2S programmable screens and function keys. A functions key editor screen allows management of global key assignment, while local key assignments are handled within the screen editor. NT2ST assigns default functions to keys for screens such as Link Screens (for navigation) and Special Screens (for data input). Screens can be programmed for scrolling text, half-screen switching, bar graphs, bit sensitive text, and numeric display and entry, all within compact, easy-to-use and understand editors. And you cannot beat the NT2ST Quickstart Guide to get your program up and running quickly.

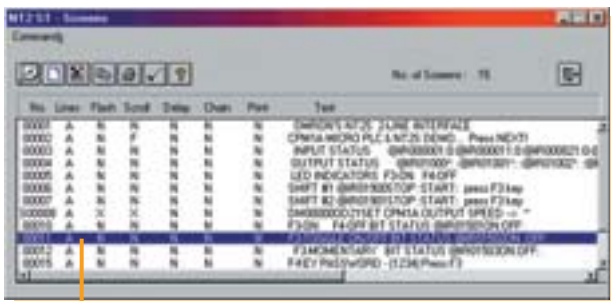

Create tag names for all PLC coils and registers from this single dialog. Refer to tags by PLC address or assigned name throughout the project.

Manage NT2S project screen and function key assignments from a single dialog box. This dialog allows screens to be created, selected for edit, and provides a quick view of properties and contents.

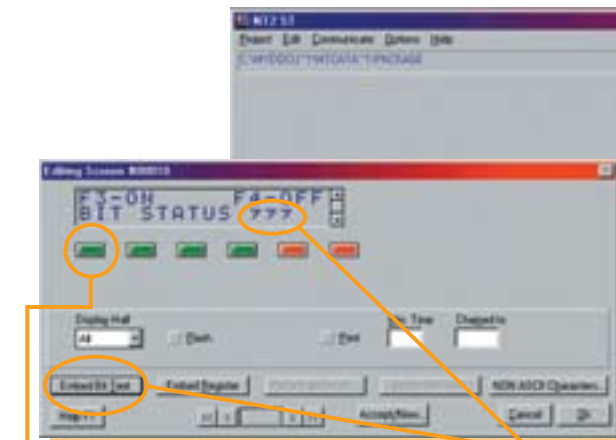

"Embed bit text" allows messages from 1 to 32 characters to be controlled by a PLC bit status. Specify ON (1) and OFF (0) text messages. NT2ST creates place holders.



Function keys can be programmed for local or global operations. Local assignment overrides global settings. Keys can manipulate words and bits in a variety of ways.



Special numeric input screens allow programmers to quickly setup data input fields. Keys 3-6 automatically default to data input keys.

Specifications

	Descriptions	NT2S-SF121B-EV2	NT2S-SF122B-EV2	NT2S-SF123B-EV2
Programming package	Windows® Software Package NT2ST	Yes	Yes	Not programmable
ASCII controlled messages	ASCII in PLC registers is displayed on the NT2S screen. Pointer in PLC memory tells NT2S which register to display. Pointers placed in that PLC register point to data value to be displayed.	No	No	Yes
Multi-vendor support	Omron, Allen-Bradley Micrologix and SLC 5/x, GE Micro, Modicon, Keyence KV Series, Toshiba T Series, Koyo 305, 405, and DL205 Series	Yes	No	No
Memory	Type EEPROM	8 K	8 K	8 K
Power	24 VDC terminals or PLC peripheral port 5 VDC	24 VDC (1.5 W max.)	5 VDC (0.75 W max.)	5 VDC (0.75 W max.)
Enclosure ratings	IP65	Yes	Yes	Yes
Standards	CE, cCSAus, UL	Yes	Yes	Yes
Ambient operating rating	0 to 50°C	Yes	Yes	Yes
Storage temperature	-20°C to 60°C	Yes	Yes	Yes
Ambient operating humidity	35% to 85% with no condensation	Yes	Yes	Yes
Ambient operating environment	No corrosive gases	Yes	Yes	Yes
Weight	400 g	Yes	Yes	Yes
Panel fitting	2 clamps	Yes	Yes	Yes
Face dimensions mm (inch)	Dimensions of NT2S front bezel	109 W x 60 H (4.29 x 2.36)	109 W x 60 H (4.29 x 2.36)	109 W x 60 H (4.29 x 2.36)
Rear unit dimensions mm (inch)	Dimensions of portion of NT2S that enters panel	91 W x 44 H x 28 D (3.58 x 1.73 x 1.10)	91 W x 44 H x 28 D (3.58 x 1.73 x 1.10)	91 W x 44 H x 28 D (3.58 x 1.73 x 1.10)
Panel cutout mm (inch)	Recommended panel cutout dimensions: 1/8 DIN	92 W x 45 H (3.62 x 1.77)	92 W x 45 H (3.62 x 1.77)	92 W x 45 H (3.62 x 1.77)
Display				
Number of screens	Max. number of screens if only text messages are used. Adding function keys, scrolling messages, etc. decreases the maximum number of screens.	250	250	Limited to PLC memory capacity for ASCII messages
Real-time clock	2-digit year, month, date, hour, minute, second	Yes	NA	NA
Bar graph display	Display numeric values as a bar graph	Yes	Yes	Yes

NT2S Dimensions

mm (inches)

NT2S-SF121B-EV2
NT2S-SF122B-EV2

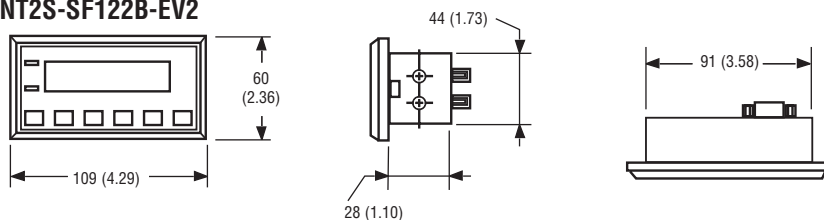

NT2S-SF123B-EV2

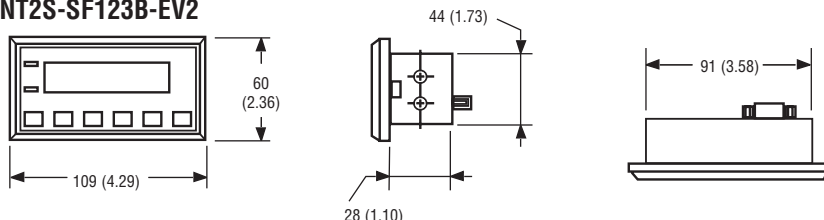

Panel cutout 1/8 DIN

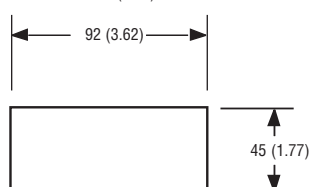

Ordering Information

Description	Part Number
NT2S Display & Cables	
2 x 16 character LCD text, 6 function key, RTC, 24 VDC	NT2S-SF121B-EV2
2 x 16 character LCD text, 6 function key, 5 VDC from PLC	NT2S-SF122B-EV2
2 x 16 character LCD text message display, 6 function key, 5 VDC from PLC	NT2S-SF123B-EV2
2 m 9 pin to peripheral port cable for SF121 model	NT2S-CN212
5 m 9 pin to peripheral port cable for SF121 model	NT2S-CN215
2 m 9 pin to peripheral (toolbus) port cable for SF122 & SF123 models	NT2S-CN222-V1
5 m 9 pin to peripheral port cable for SF122 & SF123 models	NT2S-CN225-V1
2 m 9 pin to mini-peripheral port cable for SF121 model	NT2S-CN223
2 m 9 pin to mini-peripheral port cable for SF122 & SF123 models	NT2S-CN224
2 m 9 pin to AB DH-485 1:1 connection for SF121 model	NT2S-CN212-485
NT2-Software Tool for SF121 & SF122 models	See website*
NT2-Software Tool Quickstart Guide	See website*

* Locate the free NT2ST Software Tool and Quickstart Guide at the following URL:
<http://oeiweb.omron.com/oei/TechSupport-Patches.htm>

Software
NT21/31/531
NT20S/60S
NT11S
NT2S

Technical Highlights

Technical Highlights

Contents

Cable Solutions for Omron PLCs	36 - 39
Cable Solutions for Multi-Vendor PLCs	40 - 44
NT Link Connection	45
DeviceNet Communications	46 - 48
Memory Link	49 - 51
Solve It Center - Omron Products	52 - 53
Worldwide Sales Offices	54 - 55

Cable Solutions for Omron PLCs

Operator Interface Terminals and CPM1A/CPM2A PLCs

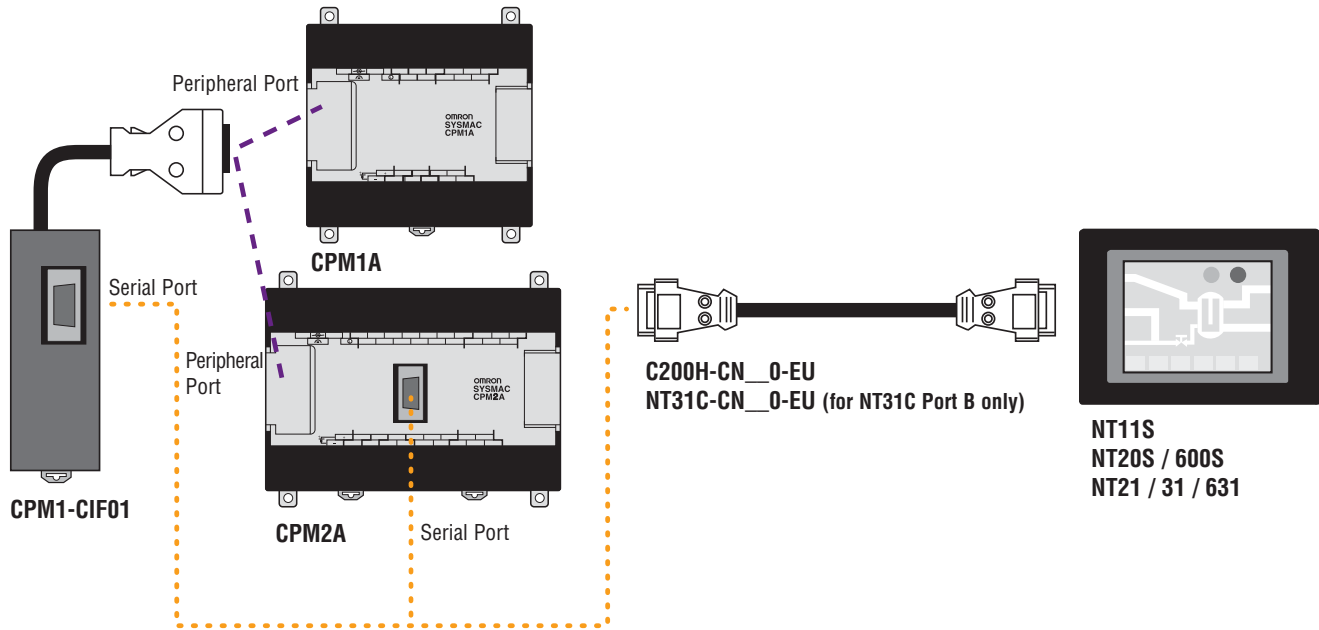

Operator Interface Terminals and CPM2C PLC

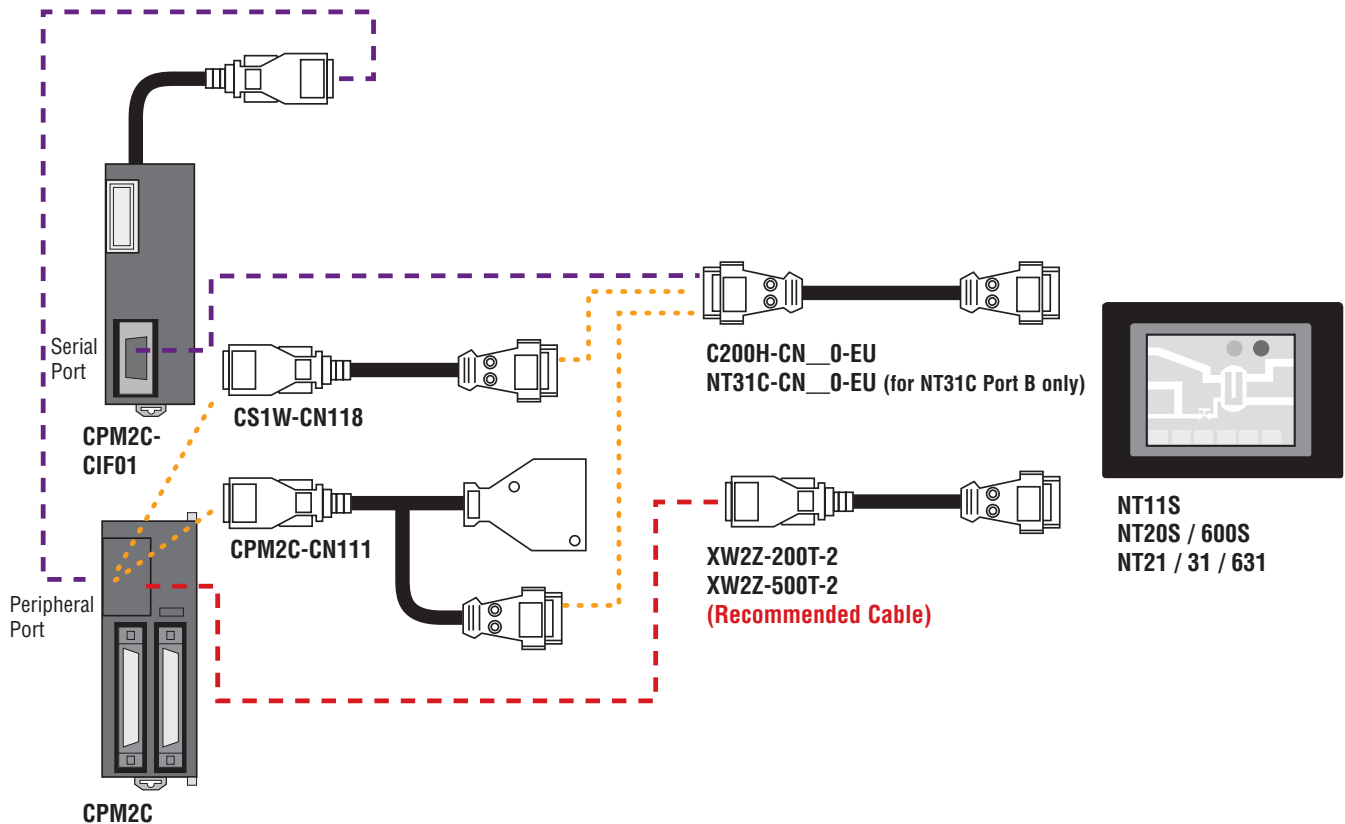

Cable Solutions for Omron PLCs

Operator Interface Terminals and CPM2B PLC

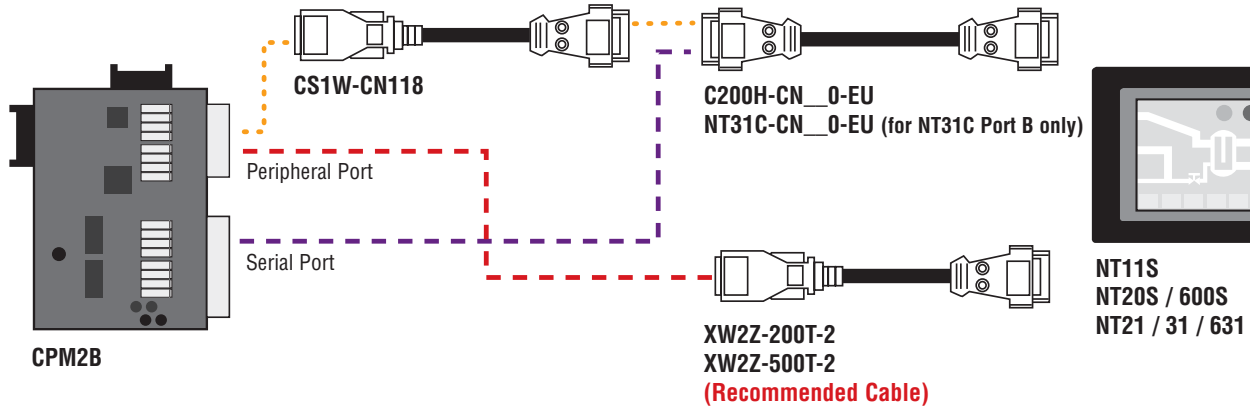

Operator Interface Terminals and CQM1H PLC

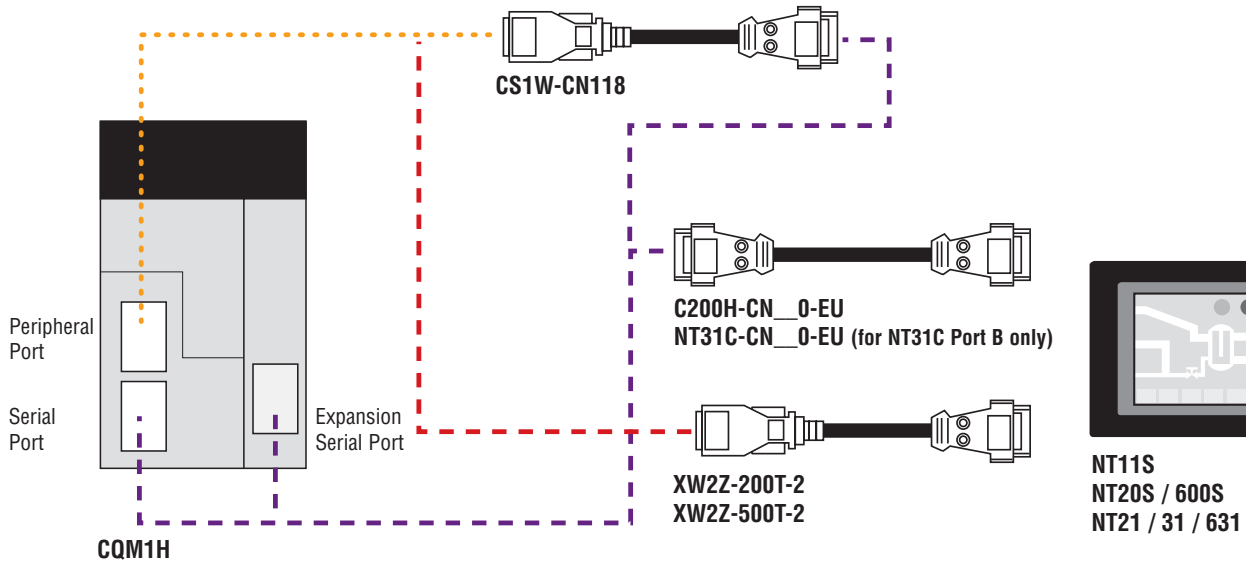

Software

NT21 / 31 / 631

NT20S / 600S

NT11S

NT2S

Technical Highlights

Cable Solutions for Omron PLCs

Operator Interface Terminals and CJ1 PLC

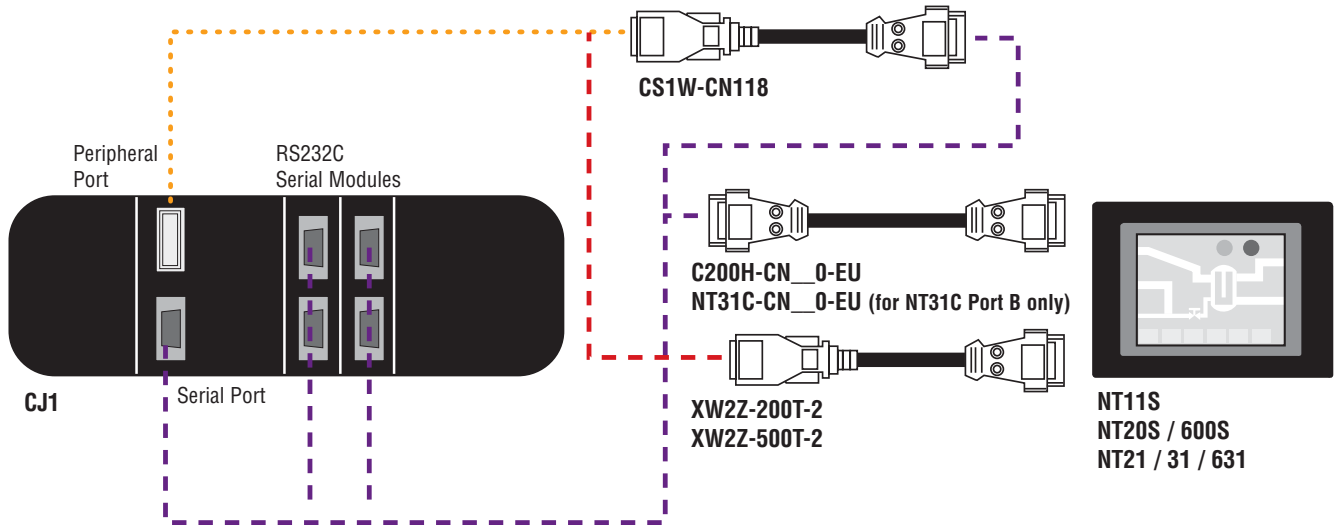

Operator Interface Terminals and CS1 PLC

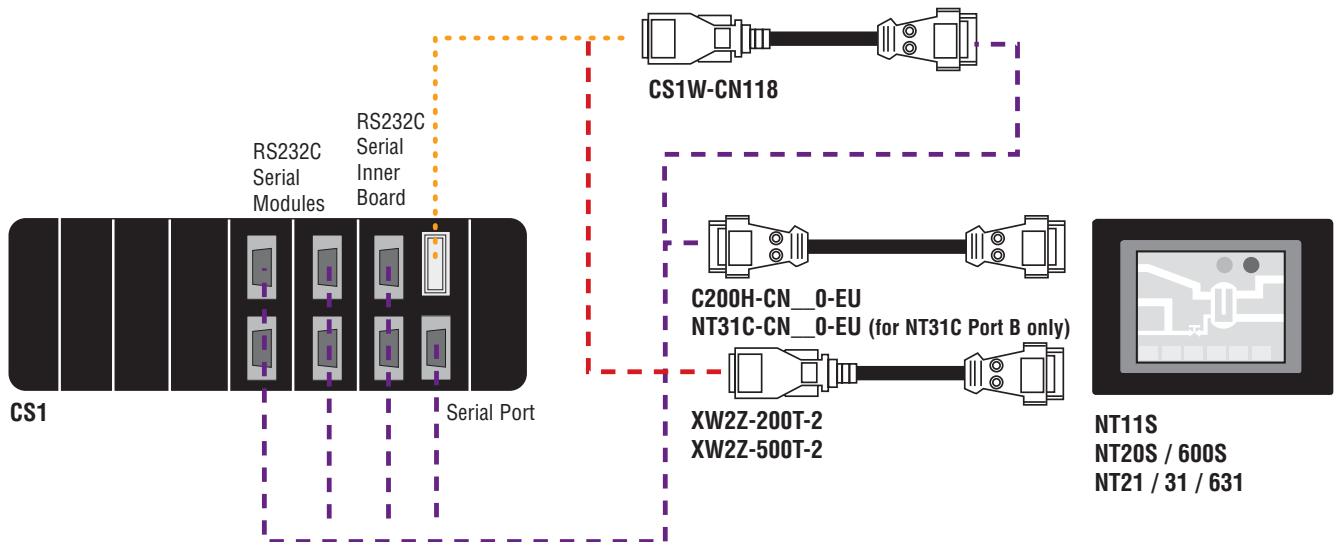

Software

NT21 / 31 / 631

NT20S / 600S

NT11S

NT2S

Technical Highlights

Cable Solutions for Omron PLCs

NT2S Message Display and Programmable Controllers

Peripheral port (Old type: C200H, SRM1, CPM2A, CPM1A)

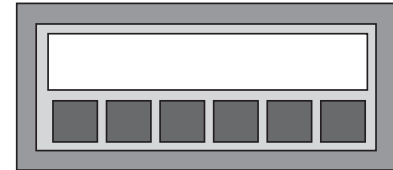
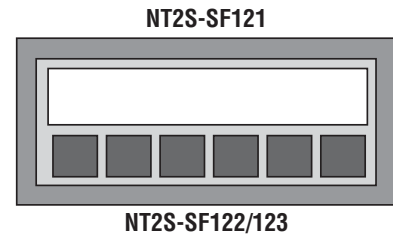

Peripheral port (New type: CJ1, CS1, CQM1H, CPM2C)

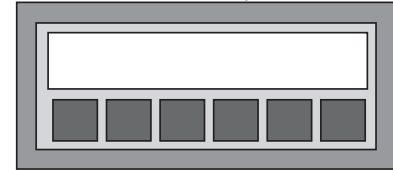
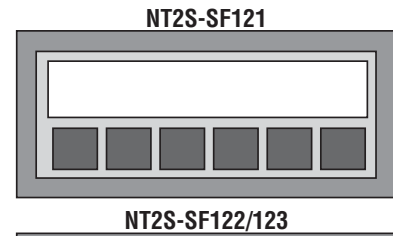

NT2S Custom Cables

Any Omron PLC Serial Port

RS232C

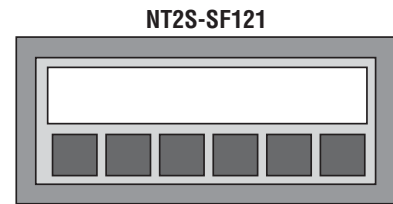
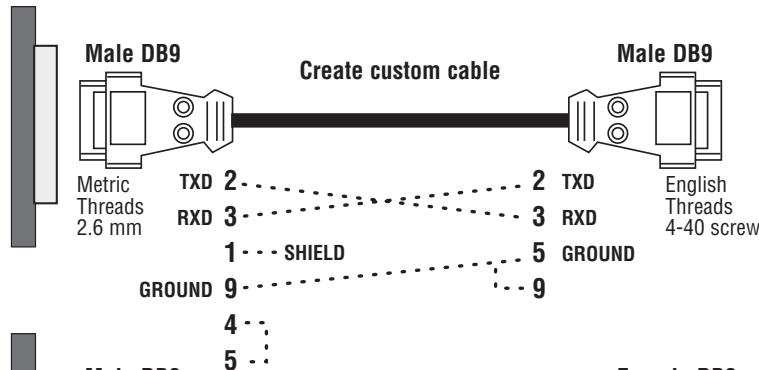

(Purchase Omron's C200H-CN320-EU and short pins 5 and 9 on NT side as shown)

Any Omron PLC Serial Port

RS232C

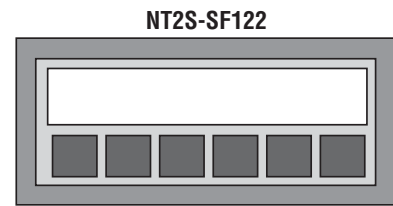
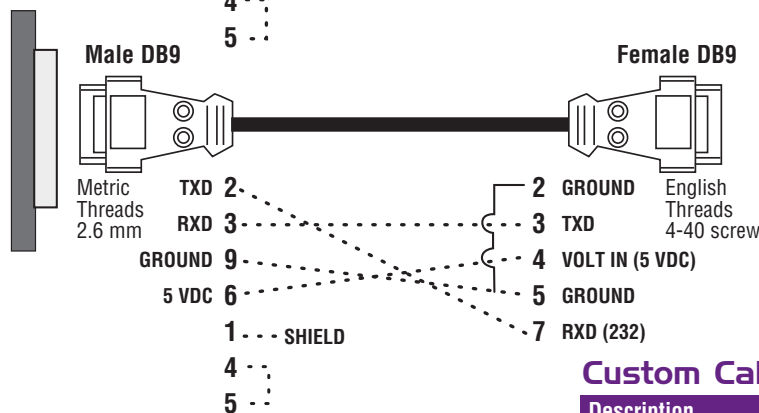

Custom Cable Ordering Information

Description	Part Number
Metric thread shell and screws - 2.6 mm	XM2S-0911
English thread shell and screws - 4-40 screw	XM2S-0913
Male connector	XM2A-0901
Female connector	XM2D-0901

Software

NT2S/31/631

NT2S/60DS

NT11S

NT2S

Technical Highlights

Cable Solutions for Multi-Vendor PLCs

Allen Bradley MicroLogix 1200

An alternative cable configuration uses a custom RS-232 9-to-9 PIN cable connecting to the Allen-Bradley 1767-CBL-PM02(Series C). The diagram below shows the pinouts for the custom RS-232 cable:

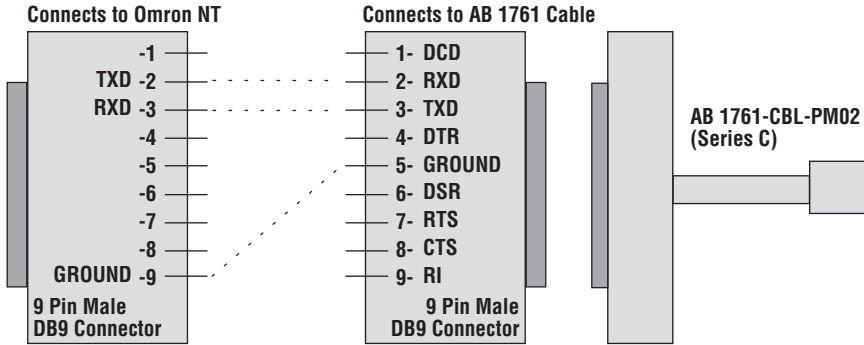

AB MicroLogix 1200 Communication Cables

1761-CBL-PM02(Series C) DB9 to 8 pin mini-din connector (order from AB)

Allen Bradley SLC 5/02

Communicates via AB's DF1 protocol. This PLC comes with only a DH-485 port. The Allen-Bradley 1747-KE module must be purchased to provide a serial connection on the SLC 5/02. Connect the communication cable from the NT to the serial port on the 1747-KE module.

AB SLC 5/02

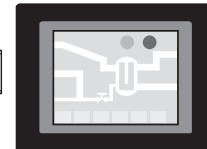
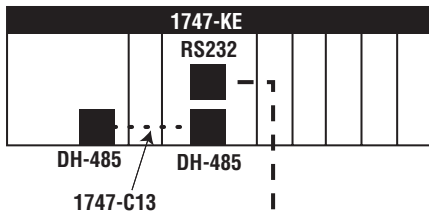

NT31 (Port A)
NT631 (Port A or B)

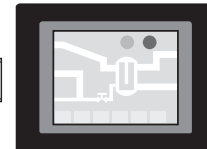

NT31 (Port B)

Allen Bradley SLC 5/00, 5/01, 5/02

This cable can only be used in 1:1 connection with DH485 port.

AB SLC 5/00, 5/01, 5/02

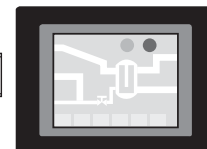
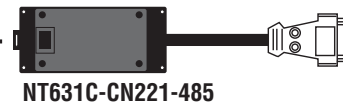
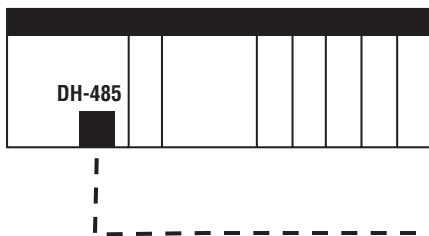

NT31 (Port A)
NT631 (Port A or B)

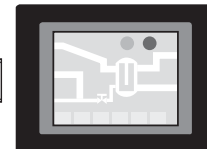
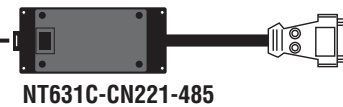

NT31 (Port A)

AB SLC 5/02 Communication Cables and Accessories

NT31C-CN321-EU	3.0 m cable, 25 to 9 pin, NT to AB SLC PLC
NT631C-CN321-EU	3.0 m cable, 9 to 9 pin, NT to AB SLC PLC
1747-KE	DB9 Serial Port Module (order from AB)
1747-C13	DH-485 module connection cable
V060-E1-2	Operation Manual – Multi-vendor Connection

Cable Solutions for Multi-Vendor PLCs

Allen Bradley SLC 5/03, 5/04, 5/05

Communicates via AB's DF1 protocol. Connect the communication cable from the NT to a serial port on the PLC using Omron cable part numbers.

AB SLC 5/03, 5/04, 5/05

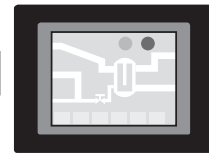
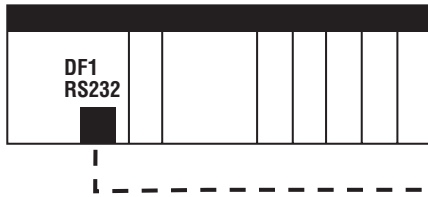

NT31 (Port A)
NT631 (Port A or B)

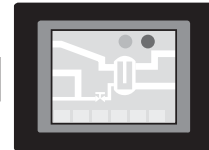

NT31 (Port B)

Allen Bradley SLC 5/03, 5/04, 5/05

This cable can only be used in 1:1 connection with DH485 port.

AB SLC 5/03, 5/04, 5/05

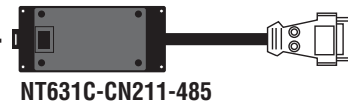
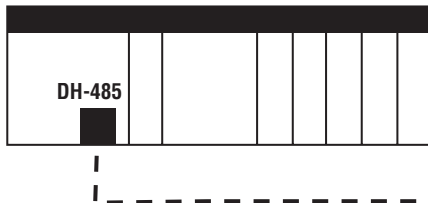

NT31 (Port A)
NT631 (Port A or B)

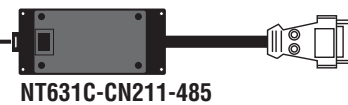

NT31 (Port A)

AB SLC 5/02 Communication Cables and Accessories

NT31C-CN321-EU	3.0 m cable, 25 to 9 pin, NT to AB SLC PLC
NT631C-CN321-EU	3.0 m cable, 9 to 9 pin, NT to AB SLC PLC
V060-E1-2	Operation Manual – Multi-vendor Connection

GE 90-20 and 90-30 Series PLCs

Communicates via GE's SNP-X protocol. The Omron NT is communicating RS-232, while the GE PLC uses RS-422. An RS232 to RS422 converter (HE693SNP232A) is needed to complete communications.

GE 90-20 and 90-30 Series

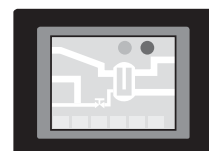
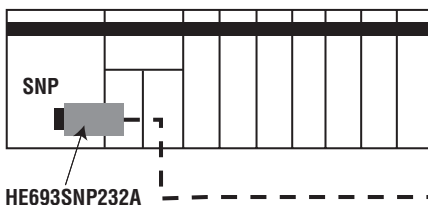

NT31 (Port A)
NT631 (Port A or B)

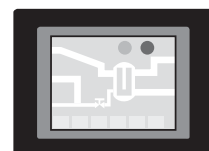

NT31 (Port B)

GE 90-20 and 90-30 Series Communication Cables and Accessories

NT31C-CN322-EU	3.0 m cable, 25 to 9 pin, NT to GE PLC
NT631C-CN322-EU	3.0 m cable, 9 to 9 pin, NT to GE PLC
HE693SNP232A	RS232 to RS422 adapter (order from GE)
V060-E1-2	Operation Manual – Multi-vendor Connection

Cable Solutions for Multi-Vendor PLCs

Siemens S7-300 and S7-400 Series PLCs

Communicates with Siemens HMI Adapter protocol. The Omron NT is communicating RS-232 to the Siemens HMI adapter, 6E57-972-OCA10-OXA0. The adapter is necessary to convert the HMI Adapter protocol into the Siemens proprietary MPI protocol.

Siemens S7-300 and S7-400 Series



6E57-972-OCA10-OXA0



NT631C-CN323-EU

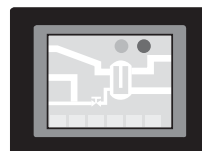

NT31 (Port A)
NT631 (Port A or B)



NT31C-CN323-EU



NT31 (Port B)

Siemens S7-300 and S7-400 Communication Cables and Accessories

NT31C-CN323-EU	3.0 m cable, 25 to 9 pin, NT to Siemens PLC
NT631C-CN323-EU	3.0 m cable, 9 to 9 pin, NT to Siemens PLC
6E57-972-OCA10-OXA0	HMI Adapter for MPI protocol (order from Siemens)
V060-E1-2	Operation Manual – Multi-vendor Connection

Mitsubishi A-Series PLCs

Communicates using Mitsubishi's Computer Link protocol. The Omron NT and the Mitsubishi A-Series PLC are communicating using RS-232 communications. Communications can be RS-422 by using custom cables as specified in Operation Manual V042-E1-1.

Mitsubishi A-Series

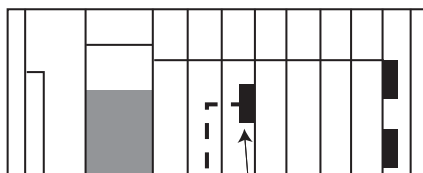

Computer Link Module



NT631C-CN324-EU

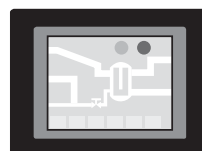

NT31 (Port A)
NT631 (Port A or B)



NT31C-CN324-EU

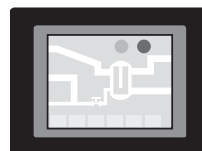

NT31 (Port B)

Mitsubishi A-Series Communication Cables and Accessories

NT31C-CN324-EU	3.0 m cable, 25 to 9 pin, NT to Mits-A PLC
NT631C-CN324-EU	3.0 m cable, 9 to 9 pin, NT to Mits-A PLC
V042-E1-1	Operation Manual – PC (Mitsubishi) Connection

Cable Solutions for Multi-Vendor PLCs

Mitsubishi FX-Series PLCs

Communicates via Mitsubishi's Computer Link protocol. The Omron NT and Mitsubishi FX-Series PLC are communicating using RS422 communications. The NT31 cable connects from the 25-pin port B, while the NT631 connects from the RS422 terminal screws for Port B.

Mitsubishi FX-Series

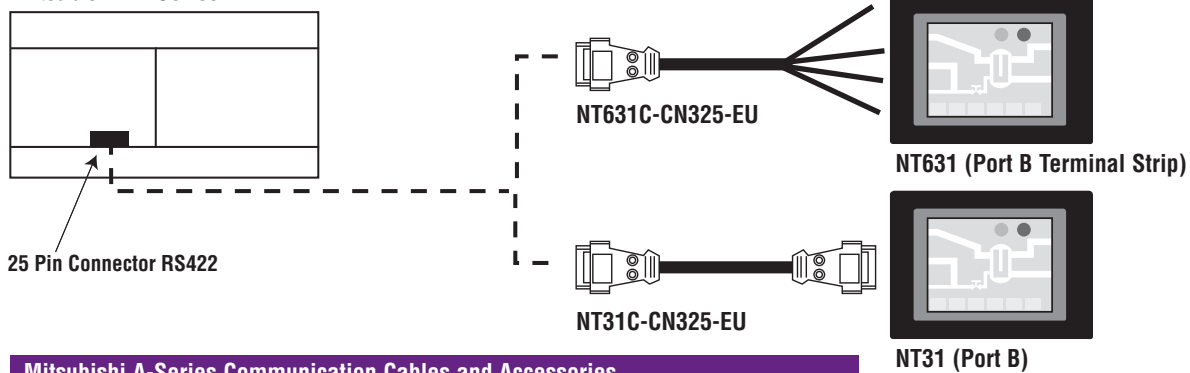

Mitsubishi A-Series Communication Cables and Accessories

NT31C-CN325-EU	3.0 m cable, 25 to 25 pin, NT to Mits-FX PLC
NT631C-CN325-EU	3.0 m cable, 4 Wires to 25 pin, NT to Mits-FX PLC
FX-20P-CADP	Cable for FX0 & FX0N PLC (buy from Mitsubishi)
V042-E1-1	Operation Manual – PC (Mitsubishi) Connection

Modicon TSX Micro 37-21/22 & Premium Series PLCs

For RS-232C connection:

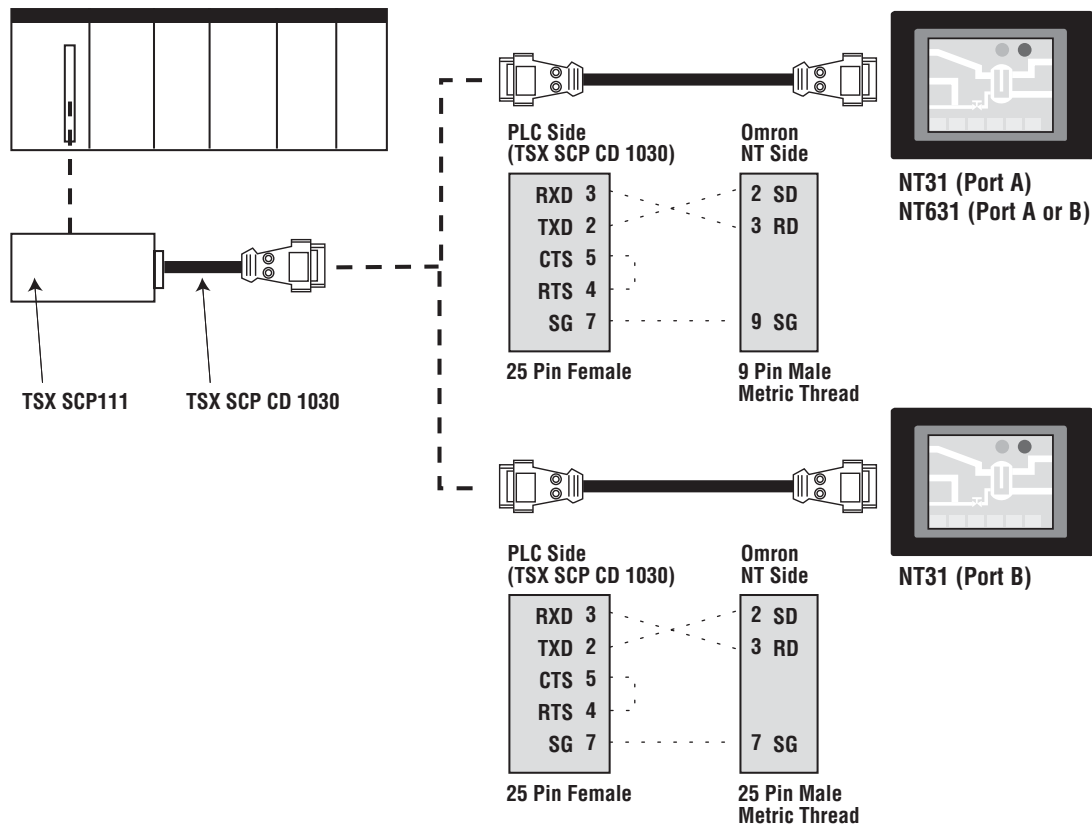

Modicon TSX Series Communication Cables and Accessories

TSX SCP111	Multi-protocol PCMCIA card for RS-232C
TSX SCP114	Multi-protocol PCMCIA card for RS-422A
TSX SCP CD 1030	Connecting cable for PCMCIA for RS-232C
TSX SCP CM 4030	Connecting cable for PCMCIA for RS-422A

Software

NT21/31/631

NT20S/60DS

NT11S

NT2S

Technical Highlights

Cable Solutions for Multi-Vendor PLCs

Modicon TSX Micro 37-21/22 & Premium Series PLCs

For RS-422A connection:

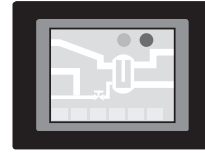
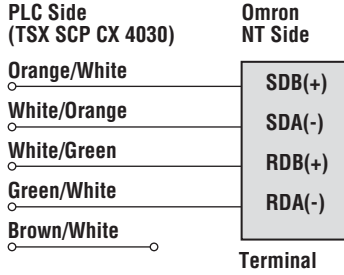
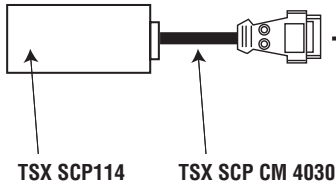

NT631 (Port B Terminal Strip)

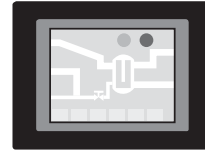
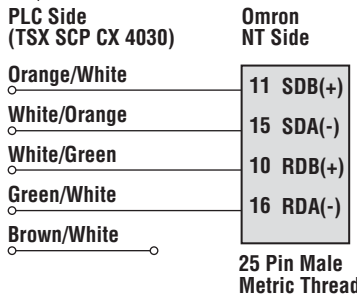

NT31 (Port B)

Modicon TSX Quantum Series PLCs

For RS-232C connection:

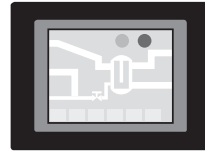
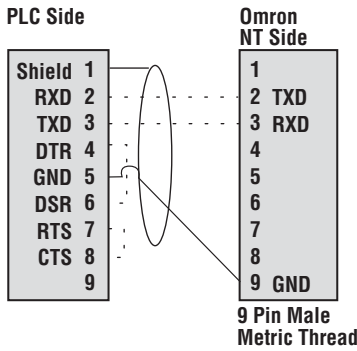

NT31 (Port A)
NT631 (Port A or B)

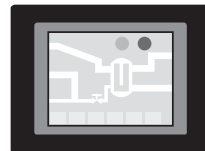
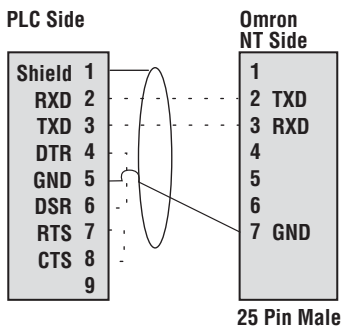

NT31 (Port B)

Software

NT21/31/631

NT209/600S

NT11S

NT2S

Technical Highlights

NT Link

NT Link is a high-speed serial protocol designed specifically for Omron HMI to Omron PLC communications. The protocol operates at 38.4 or 115.2 kbaud, the highest speed serial network in the industry. More importantly, it is not an ASCII based message. The message is very compact, addressing the words and bits in PLC memory directly. Combine a high baud rate with compact messaging and you have spectacular speed.

Compare this to Omron's open Host Link protocol, the protocol used by non-Omron HMI to communicate to Omron PLC serial ports. Host Link serial protocol operates at a maximum speed of 19.2 kbaud, and messages are transmitted using ASCII character representations of numbers. The slow baud rate combined with the larger message size translates into perceivably slower performance. The speed of NT Link translates into an increased sense of control. Operators have the sense of almost immediate response from the PLC logic and outputs. Updates report so quickly that it is almost like watching the inside of the PLC in real-time. The operator is in control. There many ways in which NT Link can be used for HMI to PLC communications. They are: NT Link 1:1, NT Link 1:N, and High Speed NT Link 1:N. Omron PLCs support the following protocols:

PLC Family	Connection	Host Link 19.2 kbaud	NT Link 1:1 38.4 kbaud	NT Link 1:N 38.4 kbaud N = 8 max	High Speed NT Link 1:N 115.2 kbaud N = 8 max
CPM1A	CPM1-CIF##	Yes	Yes	No	No
CPM2A/B/C	Peripheral Port CPM2C-CIF##	Yes Yes	Yes Yes	No No	No No
CQM1H	CPU11 Peripheral	Yes	No	No	No
	CPU21 Peripheral	Yes	No	No	No
	CPU21 Serial	Yes	Yes	No	No
	CPU51/61 Peripheral	Yes	No	No	No
	CPU51/61 Serial	Yes	Yes	No	No
CJ1	CPU Peripheral	Yes	Yes	Yes	Yes
	CPU Serial	Yes	Yes	Yes	Yes
	CJ1W-SCU#1	Yes	Yes	Yes	Yes
CS1	CPU Peripheral	Yes	Yes	Yes	Yes
	CPU Serial	Yes	Yes	Yes	Yes
	CJ1W-SCU#1	Yes	Yes	Yes	Yes

NT Link 1:N Connection

The NT Link 1:N connection allows up to 8 NT units to be connected to a single PLC serial/peripheral port. This feature is supported only on the CS1/CJ1 PLC platforms, which can have up to 34 total serial ports (2 on CPU plus 16 serial communication modules with 2 ports each.) That means a CS1 or CJ1 can connect to over 272 NT units, all communicating at 115kbaud, and with responses beating that of a single HMI connected via a Host Link driver.

NT Link 1:N connections require an RS-422A network. Some NT units include RS-422A connections (NT31 and NT631), others require an RS232C to RS422A adapter (NT20S, NT600S, NT21).

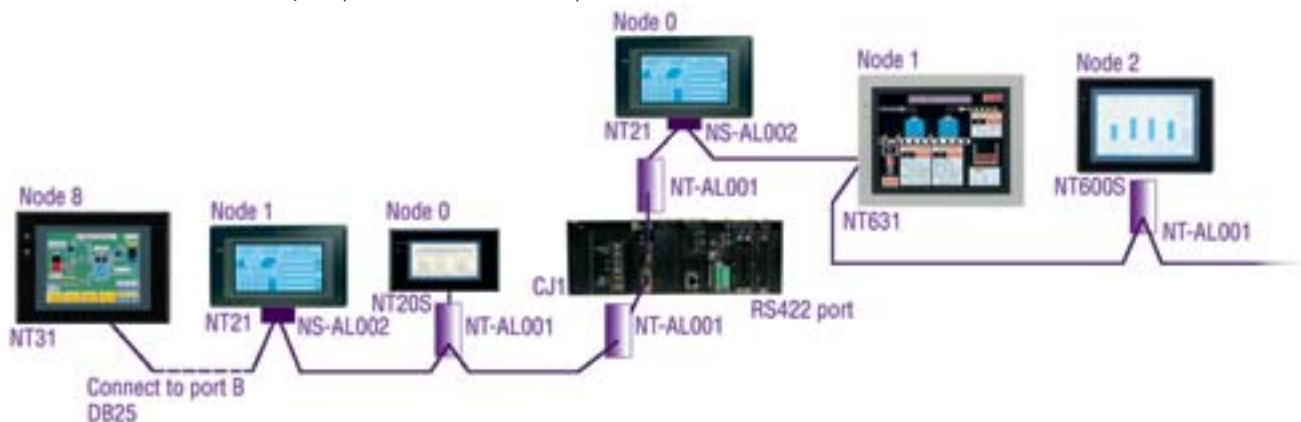

DeviceNet Communications Module for NT31/NT631

Overview

Omron's DeviceNet module for NT31 and NT631 operator interfaces provides open communications with DeviceNet masters (scanners) from any manufacturer.

Easy

Typical of Omron DeviceNet solutions, the NT-DRT21 DeviceNet module makes implementing HMI communications almost automatic. Assign a DeviceNet network node number to the NT operator interface and Omron's DeviceNet master automatically enrolls the unit, establishing communications without further configuration. Up to 32 input and 32 output words can be mapped automatically and are continuously scanned by the DeviceNet master. An additional 120 words of data can be accessed within the HMI using Explicit Messaging on the DeviceNet network.

Convenient

Reduce wiring effort and expense by placing your HMI onto the existing DeviceNet network. There is no need to run additional serial cables for operator interface communications. The operator interface can reside on the I/O network up to 500 meters away from the DeviceNet master.

Open communication standard

The NT-DRT21 is compatible with third-party DeviceNet masters, so the NT31/631 units can be placed on any system, allowing a facility to standardize on the Omron NT31/631 platform. Programmed NT31/631 units can be used with masters from different vendors without changing the screen program.

Specification Highlights

- NT-DRT21 module mounts on the back of NT31 and NT631 operator interfaces
- Reserve up to 32 input and 32 output words as Remote I/O for continuous update from the DeviceNet master
- 120 additional words of NT memory are accessible using explicit commands from the PLC
- Locate the touch screen up to 500 meters from the PLC on the DeviceNet network
- Baud rate up to 500 kbps
- Program the operator interfaces using NT-Series Support Tool (NTST)
- Operator interfaces are programmed to reference an internal memory area, words 0 through 9999

Hardware Operation

Upgrade operating system

The NT31/631 units are shipped with an operating system (OS) that supports communication. This OS must be replaced with one that supports the NT-DRT21 interface module. Simply connect to Port A on the NT31/631 with the C200H-CN229-EU communication cable, plug into your PC serial port, and use the NT-Series System Installer (included with NTST) to download the DeviceNet OS.

Connect

The NT-DRT21 module mounts to the expansion interface connector on the back of the NT31/631 unit, as illustrated. Connect the NT-DRT21 to the DeviceNet network 5-wire cabling.

Set communication parameters

The system menu for the NT31/631 DeviceNet OS contains the following parameters:

- Communication Speed (Baud Rate): 125, 250, or 500 kbps
- DeviceNet Node Number: 0 to 63
- Strobe ON Time: 30 to 100ms
- Output Area Leading Address: Memory Link word 0000 to 9999
- Output Area Size: 5 to 32 words
- Input Area Leading Address: Memory Link word 0000 to 9999
- Input Area Size: 5 to 32 words

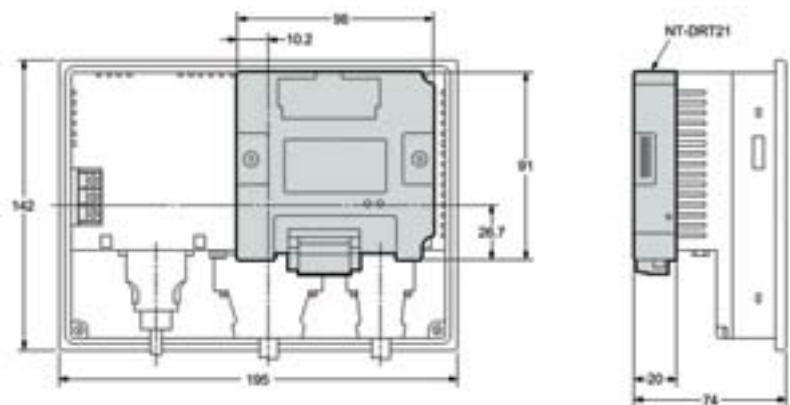

DeviceNet Communications Module for NT31/NT631

Programming Overview

Create project

Using NTST, create a screen project configured for Memory Link, as shown to the right in Diagram A. The illustration in Diagram B shows how information flows from a touch screen object to the DeviceNet network. Screen objects within the NT31/631 are programmed in NTST to refer to the screen's internal Memory Link memory area, addressed from 0000 to 9999, as shown in Diagram C. The NT-DRT21 module then automatically coordinates communication between the Memory Link memory area and the DeviceNet master.

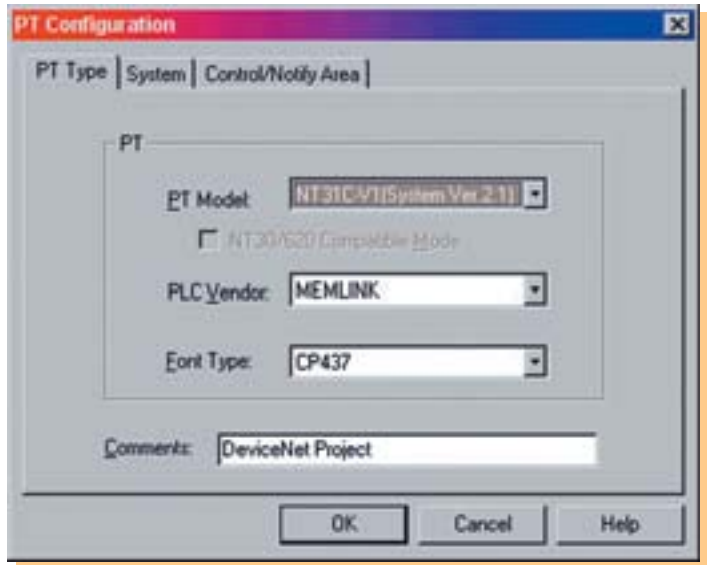

Diagram A



Diagram C

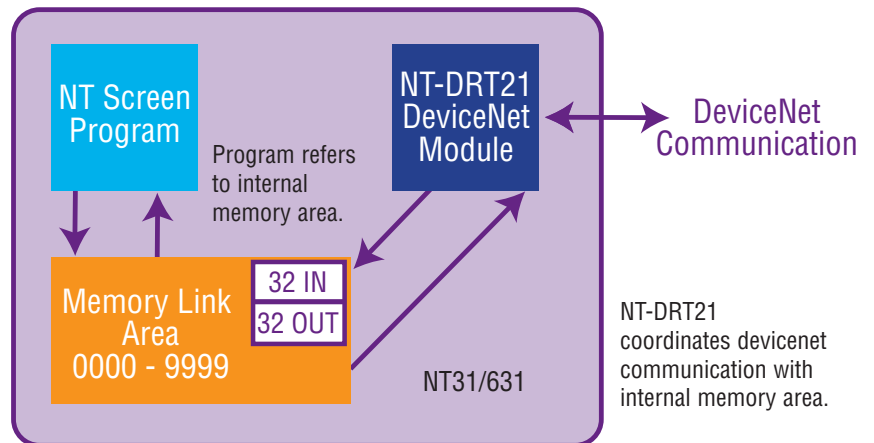

Diagram B

DeviceNet Communications Module for NT31/NT631

Software

NT21/31/631

NT203/600S

NT11S

NT2S

Technical Highlights

Network Configuration Options

Two factors determine how many operator interface terminals can be used on a DeviceNet network:

- Remote I/O capacity available on the network.
- Number of words allocated in the NT31/631 for Remote I/O.

The model of the DeviceNet master and number of devices on the network determine how much Remote I/O is available. If Remote I/O space is limited, more NT31/631 can be placed on the network by reducing the number of the input and output words reserved by the NT-DRT21 unit. Refer to the following charts.

Weighing the options

DeviceNet I/O modules on the network use up Remote I/O capacity, reducing the number of NT units on the network. A DeviceNet Configurator increases the capacity by deactivating explicit messaging and freeing up reserved memory, increasing available Remote I/O capacity and allowing more NT units to be connected to the network. However, explicit messaging can access 120 additional words in the NT memory area. Deactivating the explicit messaging eliminates this option.



Word Capacity of Omron DeviceNet Masters

DeviceNet master	Fixed allocation capacity without configurator		Free allocation capacity with configurator (explicit messaging disabled)	
	Input words	Output words	Input words	Output words
CS1W-DRM21, CJ1W-DRM21	500	500	1000	1000

Calculating the Number of NT31/631 Units

The following examples illustrate the impact of Remote I/O availability and use of a configurator.

DeviceNet master	Input and output words allocated in NT31/631 memory	Using Configurator with Explicit Messaging disabled?	Max Number of NT31/631 that can be placed on the network
CS1W-DRM21	32 IN/32 OUT	No	15
CJ1W-DRM21	32 IN/32 OUT	Yes	31
CJ1W-DRM21	12 IN/8 OUT	No	41

Ordering Information

Description	Part Number
DeviceNet Interface Module for NT31/NT631 touch screens	NT-DRT21
NT-Series Support Tool (NTST)	NT-ZJCAT1-EV4
PC to NT unit connecting cable for screen data and operating system downloads	C200H-CN229-EU
NT-DRT21 Operation Manual	V066-E1-1
CVM1 & C200HW DeviceNet Master Operation Manual	W267-E1-4
CJ1 & CS1 DeviceNet Master Operation Manual	W380-E□-□

Applicable Operator Interfaces

Description	Part Number
5.7 Monochrome STN LCD touch screen	NT31-ST121□-EV2
5.7 Color STN LCD touch screen	NT31C-ST141□-EV2
11.3 Color STN LCD touch screen	NT631C-ST141□-EV2
10.4 Color TFT LCD touch screen	NT631C-ST151□-EV2
10.4 Electroluminescent touch screen	NT631-ST221□-EV2

Memory Link

Get the advantages of using Omron's NT31/NT631 operator interfaces with a PC or single board computer for an economical control/display package. The Memory Link feature translates PC serial output to operator terminal protocol and communicates display status back to the PC. A common memory table stores the shared data. This arrangement capitalizes on the strengths of each component: the PC control platform handles the controls and the operator terminal handles the display tasks. Here is how Memory Link can keep costs down.

- Display the output from an embedded PC, PC104 or other serial device without having to install a video board or other converter hardware
- Eliminates the need to write your own or use third-party graphical user interface software to create graphics for touch screens
- Reduces installed hardware costs by using low-cost processors
- Easy to customize the display for short runs of machines

Specifications

- Up to 10,000 words of internal memory allocated for reading and writing data between an Omron operator interface terminal and host device
- Serial communications: RS-232 or RS-422 connection
- Transmission distance between touch screen and PC: 50 ft max. (RS-232); 150 ft max. (RS-422)

Serial Data Exchange Commands

The NT31/631 writes its memory and memory table information to the internal Memory Link area. Data is then processed between this area and the host via serial commands. Here are the commands available:

Data Read Commands/Responses

These commands are used for reading the contents of the NT memory and memory tables. They are issued from the host and the NT unit responds by returning the requested data from the specified Memory Link table location.

- NT Memory Read Command
- Numeral Memory Table Command
- Character-String Memory Table Read Command
- Bit Memory Table Read Command
- Screen Data Comment Read Command
- System Status Read Command

Data Write Commands/Responses

These commands are used for writing data to the NT memory area. They are issued from the host to update NT memory area with new data. The NT screen objects and memory tables reference the memory area and display the new data values. The NT can be set to respond back to the host indicating whether or not the data write was completed successfully.

- PT Memory Write Command
- Numeral Memory Table Write Command
- Character-String Memory Table Write Command
- Bit Memory Table Write Command
- PT Memory Batch Write Command
- Numeral Memory Table Clear Command
- Character-String Memory Clear Command
- Bit Memory Table Clear Command

Notify

These commands are used to notify the host of NT operations. They are issued from a Memory Link table location of the NT unit and require no response from the host.

- Touch Switch Input Notify Command
- Numerical Input Notify Command
- Character-String Input Notify Command
- Direct Area Changing Notify Command
- PT Memory Changing Notify Command

Operation Mode Switch

This command is used to switch operating modes of the NT unit either "Run" to "Transmit" or from "Transmit" to "Run." It is issued from the host

- NT Operation Mode Switch Command

Re-Send

This command allows the NT unit to re-send the last sent notify command to the host. It is issued from the host.

- Re-Send Request Command

Error Response

This command is to notify the host that the command sent contained an error. It is issued from the NT unit to the host.

- Error Response Command

Memory Link

Single Board Controller with RS-232 Connection to NT31/631

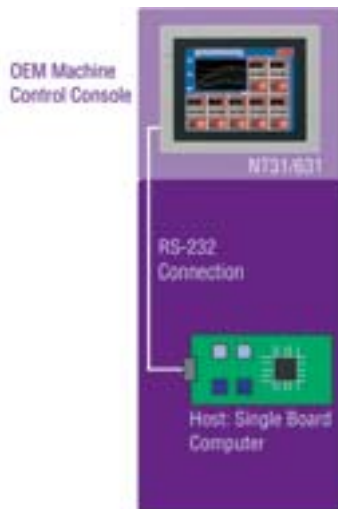

Host PC with RS-422 Connection to NT31/631



Time Saving Program Reuse

NT projects designed for Omron PLC connection can be converted to a Memory Link project with the NTST programming tool. This saves time allowing PLC projects to be reused.

Memory Link Examples

When using the NT Memory Link feature, commands are issued between the various NT screen objects and the internal Memory Link table of the NT. Each screen object refers to a location in the Memory Link table. Serial Memory Link commands, composed of ASCII characters, are then passed between the NT's Memory Link table and an external host device such as a PC or single board computer. Control objects such as lamps and touch switches, and tables such as the Numeral Table, refer to the NT memory area (Memory Link Table).

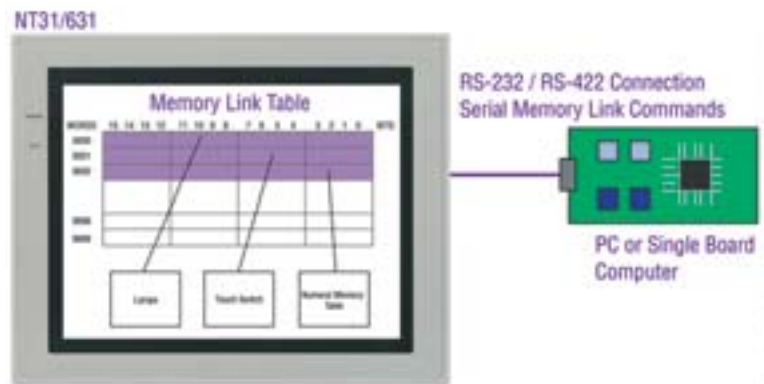

Memory Link Command Structure

A Memory Link Command has the following format:

Request sent from host

[ESC]	R	M	m	c1	c2	c3	c4	I1	I2	s1	s2	[CR]
1B	52	4D	❖❖	❖❖	❖❖	❖❖	❖❖	❖❖	❖❖	❖❖	❖❖	0D

m: Check sum present/absent (1 BCD digit)
 0 = Absent
 1 = Present
 8 = Absent (1 word read)
 9 = Present (1 word read)

c1 to c4: Start word number to read (4 BCD digits) 0000 to 9999

I1, I2: Number of words to read (2 BCD digits)
 00 – block read 100 words
 01 to 99 – 1 to 99 words read
 When m is (8) or (9), omit this setting

s1, s2: Check sum (2 hex digits)
 When m is (0) or (8), omit this setting

Request sent from NT

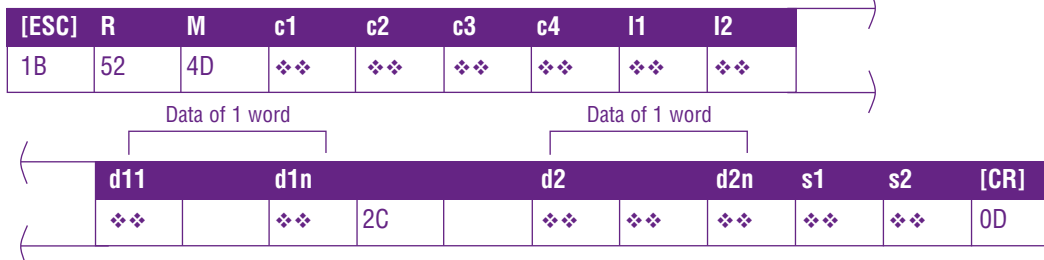

c1, to c4: Start word number to read (4 BCD digits) 0000 to 9999

I1, I2: Number of words to read (2 BCD digits)
 01 to 50 – 1 to 50 word

d11 to d1n d2 to d2n: Contents of the read words (1 to 4 hex digits) 0 to FFFF

s1, s2: Check sum (2 hex digits)

Memory Link

PT Memory Read Command

The following is an example how the available command set would be used for Memory Link communications between an NT and host (PC/Single board computer):

Memory Link Table Word Mapping

Device	Word	Value
Lamp 1	000100	1
Lamp 2	000101	1
Touch Switch 1	000215	0

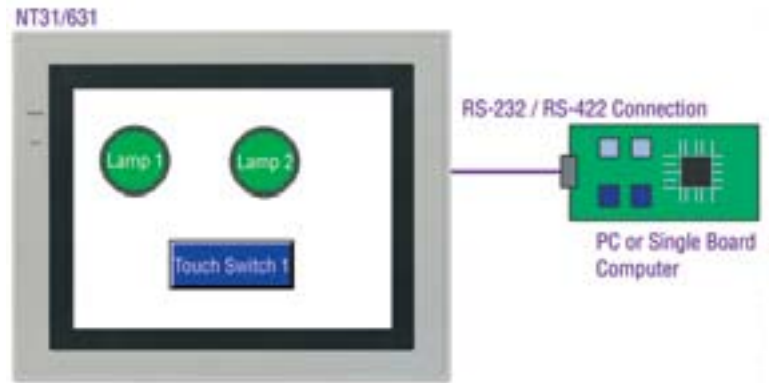

This example shows the use of the PT Memory Read Command for the above NT screen, it will be executed from the host (PC/Single Board Computer) via the serial port. The response from the NT unit will be the status of Lamp 1, Lamp 2, and Touch Switch 1:

Request sent from host

[ESC]	R	M	0	0	0	0	1	0	2	[CR]
1B	52	4D	30	30	30	30	31	30	32	0D

Response sent from NT

[ESC]	R	M	0	0	0	1	0	2	
1B	52	4D	30	30	30	31	30	32	
	3	,	1	5	0	0	6	7	[CR]
	33	2C	31	35	0	0	36	37	0D

solve it.[™] center

Advanced Industrial Automation Products and Control Components for all your applications



Bar Code Readers

Omron's cost-effective bar code readers are the ideal solution for high-volume, basic identification and verification applications. Choose from fixed position laser scanners, raster models, and 2-dimensional code readers.



Counters and Timers

Clearly display critical values within a wide range of engineering or time units. We offer robust, NEMA4 models and several different display options that fit your application and budgetary requirements.



DeviceNet Products

As a founding member of the Open Device Vendor Association (ODVA), Omron is committed to promoting DeviceNet as an open platform and we have the industry's broadest offering of DeviceNet products and expertise.



Digital Panel Meters and Displays

Whether you need an intelligent panel meter with built-in display and control functions, or a simple digital display, choose Omron. Select models with communications options, comparative outputs, and NEMA4X-rated, front panels.



Inverters

Get advanced speed control and 179 user-configurable parameters in a compact housing with an Omron AC inverter. At only 5" high, the micro inverters save panel space and are ideal for small motor applications.



Operator Interfaces

Clearly convey information using the powerful graphics of touchscreens. These space-saving interfaces have large image libraries, easy to use programming software, and multi-vendor communication drivers.



PCB Inspection Systems

Omron's VT-WIN PCB solder inspection system accurately evaluates solder joints and component placements at production speeds and can share inspection results via your existing Ethernet network.



Power Supplies

Countless applications rely on Omron's switching power supplies. They offer unrivaled wattage and output options while meeting the latest UL508 and Class 2 standards.



Process and Temperature Controllers

Accurately control temperature in your critical applications with one of Omron's process and temperature controllers. We offer everything from DeviceNet ready units to field-selectable sensor inputs and interchangeable plug-in outputs.



Programmable Controllers

From large, sophisticated systems to smaller, more specialized controllers, Omron is a recognized leader in technology, performance, and quality. Our models have varying I/O capacities, sizes, and communication options to solve your applications.



Radio Frequency Identification (RFID)

Make wireless data tracking a bigger part of your operation and minimize recording errors with an RFID system. Omron offers a wide variety of antennas and tags with different sizes, transmitting ranges and memory capacities.



Remote I/O and Wiring Solutions

Tame tangled webs of I/O wiring in your control panels and achieve high-speed, bit-level communications with our remote I/O and wiring solutions. We have the tools to reduce wiring time, lower installation costs and speed communications.



Sensors

Omron is #1 in photoelectric and proximity sensors, leading the world in technology, solutions and quality. Additional sensor offerings include: limit switches, safety products, encoders, pressure and ultrasonic sensors.



Servo Motors and Drives

For precise control, the W-Series Servo can interface quickly and easily with Omron PLCs using plug-and-play cabling. With output capacities up to 5.5 kW and different motor types, the W-Series ideally suits a wide variety of applications.



Software

Configuring and programming your Omron hardware is quick and easy with our software tools. Omron's sophisticated software lets you unlock the advanced features of our products to solve your industrial automation applications.



Vision Sensors and Systems

Whether you need gray scale, binary, or color processing, Omron's vision sensors or systems can meet your needs. We deliver a complete solution, from software to lighting, cameras, and lenses.



Card Readers

Read and/or write to magnetic stripes and smart cards with our card readers. We offer many different styles of card readers to solve your access control, data tracking and POS applications.



Photomicrosensors

Choose from several mounting, termination and output models to solve difficult detection and switching problems. Optical circuitry eliminates contact bounce, providing unsurpassed product life.



Relays

Omron is #1 in relays, leading the world in new technologies and innovations. Our low signal, general-purpose, solid state, and power PCB relays deliver unmatched selection of sizes, capacities, and performance.



Switches

Omron offers thousands of high quality, reliable switches, suitable for your applications. Flexible options include actuator styles, sealability, switching configuration, load ratings and termination style.

Omron offers local sales and technical support around the corner and around the globe. Our products meet international standards, so you can confidently ship your products with Omron components and systems anywhere in the world.

The organizations listed here do not include the local distributors in each region. Please contact the main office for information.

AMERICAS

USA

Omron Electronics LLC
One East Commerce Drive
Schaumburg, Illinois 60173
Phone: (800) 55-OMRON
(847) 843-7900
Fax: (847) 843-7787

Atlanta

Omron Electronics
6200 The Corners Parkway
Suite 200
Norcross, Georgia
Phone: (770) 798-6780
Fax: (770) 798-6788

Boston

Omron Electronics
65 Boston Post Road West, Suite 220
Marlborough, MA 01752
Phone: (508) 303-8880
Fax: (508) 303-8881

Chicago

Omron Electronics
1300 Basswood, Suite 300
Schaumburg, IL 60173
Phone: (847) 843-7910
Fax: (847) 882-3887

Cincinnati

Omron Electronics
8160 Corporate Park Drive, Suite 100
Cincinnati, Ohio 45242
Phone: (513) 469-6766
Fax: (513) 469-5737

Dallas

Omron Electronics
3001 Skywalk Circle North, Suite 110
Irving, Texas 75038
Phone: (972) 871-2166
Fax: (972) 871-2182

Los Angeles

Omron Electronics
750 The City Drive South, Suite 120
Orange, California 92868
Phone: (714) 621-3455
Fax: (714) 621-3467

Philadelphia

Omron Electronics
180 Sheree Boulevard, Suite 3800
Exton, Pennsylvania 19341-1280
Phone: (610) 524-1897
Fax: (610) 524-5631

ARGENTINA

Cuba 1940 Piso 11
1428 Buenos Aires, Argentina
Phone: 54-114-787-1129
Fax: 54-114-787-1139

BRAZIL

Omron Electronica do Brasil, Ltda.
Av. Santa Catarina, 935/939
04378-300 São Paulo-SP, Brazil
Phone: 55-11-5564-6488
Fax: 55-11-5564-7751

CANADA

Omron Canada, Inc.
885 Milner Avenue
Scarborough, Ontario M1B 5V8
Phone: (416) 286-6465
Fax: (416) 286-6648

Ontario

Omron Canada
60 New Dundee Road
Kitchener, Ontario N2G 3W5
Phone: (519) 896-1144
Fax: (519) 896-0333

Omron Canada

1382 Richards Road
Kingston, Ontario K0H 2L0
Phone: (613) 376-3968
Fax: (613) 376-9937

British Columbia

Omron Canada
1610 Derwent Way, Unit 27
Annacis Isle., British Columbia V3M 6W1
Phone: (604) 522-8855
Fax: (604) 522-9306

Alberta

Omron Canada
8864 60th Ave.
Edmonton, Alberta T6E 6A6
Phone: (888) 522-8855 or (780) 440-0818
Fax: (780) 462-9327

Omron Canada

30 Weat Terrace Drive
Calgary, Alberta T0L 0W4
Phone: (403) 932-5395
Fax: (403) 932-6843

Quebec

Omron Canada
1825 32nd Avenue
Lachine, Quebec H8T 3J1
Phone: (514) 636-6676
Fax: (514) 636-2959

Omron Canada

3107 Des Hotels #10
Ste-Foy, Quebec G1W 4W5
Phone: (418) 658-2735
Fax: (418) 658-9072

EUROPE

AUSTRIA

Omron Electronics G.m.b.H.
Altmannsdorfer Strasse 142
Vienna, Austria, A-1231
Phone: 43-1-801-90-0
Fax: 43-1-804-48-46

BELGIUM

Omron Electronics N.V./S.A.
Stationsstraat 24
Groot-Bijgaarden, Belgium, B-1702
Phone: 32-2-466-2480
Fax: 32-2-466-0687

CZECH REPUBLIC

Omron Electronics Spol. S.R.O.
Srobarova 6
CZ-101 00 Prague 10
Phone: 420-2-67311-254
Fax: 420-2-71735613

DENMARK

Omron Electronics A/S
Odinsvej 15
Glostrup, Denmark, DK-2600
Phone: 45-43-44-00-11
Fax: 45-43-44-02-11

FINLAND

Omron Electronics O.Y.
Metsanpojankuja 5
Espoo Finland FIN-02130
Phone: 358-9-5495800
Fax: 358-9-54958150

FRANCE

Omron Electronics S.a.r.l.
BP 33, 19 Rue Du Bois Galon
Fontenay-Sous-Bois/Cedex
Paris, France, F-94121
Phone: 33-1-4974-7000
Fax: 33-1-4876-0930

GERMANY

Omron Electronics G.m.b.H.
Elisabeth-Selbert-Strasse 17
40764 Langenfeld, Germany
Phone: 49-2173-6800-0
Fax: 49-2173-6800-400

GREECE

Kalamarakis & Sapounas, S.A.
10 Great Kydonion Street
Athens, Greece, GR-111 44
Phone: 30-1-2235-511/512/513
Fax: 30-1-2027-500

HUNGARY

Omron Electronics Ltd.
Kiss Emo u. 1-3
Budapest, Hungary, H-1046
Phone: 36-1-399-3050
Fax: 36-1-399-3060

IRELAND

Omron Electronics Ltd.
1 Apsley Way
Staples Corner, London NW2 7HF
England
Phone: 20-8450-4646
Fax: 20-8450-8087

ITALY

Omron Electronics S.r.l.
Viale Certosa 49
Milano, Italy, 20149
Phone: 39-2-32-68-1
Fax: 39-2-32-51-54

NETHERLANDS

Omron Electronics B.V.
Wegalaan 61
JD Hoofddorp, Netherlands, NL-2132
Phone: 31-2356-81-100
Fax: 31-2356-81-188

NORWAY

Omron Electronics Norway A/S
Ole Deviks vei 4
Oslo, Norway, N-0611
Phone: 47-22-65-75-00
Fax: 47-22-65-83-00

POLAND

Omron Electronics SP. Z.O.O.
Ul Jana Sengera Cichogol
Warsaw, Poland PL 02 790
Phone: 48-22-645-7860
Fax: 48-22-645-7863

PORTUGAL

Omron Electronics LDA
Edificio Omron
Rue de Sao Tome, Lote 131
Prior Velho, Portugal 2685
Phone: 351-1-941-9400
Fax: 351-1-941-7899

RUSSIA (CIS)

Omron Electronics
Sredniy Tishinskiy per.,
28/1 Moscow, 123557, Russia
Phone: 7-095-745-2664
Fax: 7-095-745-2680

SPAIN

Omron Electronics, S.A.
Calle Arturo Soria 95
Madrid, Spain, E-28027
Phone: 34-91-37-77-900
Fax: 34-91-37-77-956

SWEDEN

Omron Electronics A.B.
Norgegatan 1
Kista, Sweden S-164 28
Phone: 46-8-632-35-00
Fax: 46-8-632-35-10

SWITZERLAND

Omron Electronics A.G.
Sennweidstrasse 44
Steinhausen, Switzerland CH-6312
Phone: 41-41-748-1313
Fax: 41-41-748-1345

TURKEY

Omron Electronics Ltd.
Acibadem Caddesi
Palmiye Sokak 12
Kadikoy-Istanbul, Turkey, TR 81020
Phone: 90-216-326-2980/2981/2982
Fax: 90-216-326-2979

U.K.

Omron Electronics Ltd.
1 Apsley Way
Staples Corner, London NW2 7HF
England
Phone: 20-8450-4646
Fax: 20-8450-8087

MIDDLE EAST & AFRICA

EGYPT

Union
19 Gezirat Al Arab Str.
Al Mohandeseen, Giza, Egypt
Phone: 202-304-2165/2166
Fax: 202-304-6946

ISRAEL

Ateka Ltd.
23 Hayetzira Street P.O. Box 3120
Kyriat Aryeh, Petach-Tikva, Israel 49512
Phone: 9732-939-2333
Fax: 9723-924-3273

KUWAIT

Ammar & Partners Electrical Co.
P.O. Box 1871
Safat, Kuwait 13019
Phone: 965-48301222
Fax: 964-4841818

MOROCCO

Mest Composants
4, Rue De Provens
Casablanca, Morocco 21700
Phone: 212-2-302-824
Fax: 212-2-301-4900

SAUDI ARABIA

Tayseer Al-Sheikh Corporation
Khalid Bin Waleed Street
P.O. Box 19865
Jeddah, Saudia Arabia 21445
Phone: 966-2-6717285
Fax: 966-2-6731910

SOUTH AFRICA

Yelland Control
P.O. Box 14601
1422 Gauteng Prouirce
Wadeuille, South Africa
Phone: 2711-824-3460
Fax: 2711-827-9861

TUNISIA

Axafrica
10 Avenue Habib Bourguiba
Tunis, Tunisia 1001
Phone: 216-1-344-103
Fax: 216-1-343-527

UNITED ARAB EMIRATES

Deira General Marketing
P.O. Box 11370,
Dubai, U.A.E.
Phone: 9714-624111
Fax: 9714-213942

OCEANIA & ASIA

AUSTRALIA

Omron Electronics Pty. Ltd.
71 Epping Road
North Ryde, Sydney
New South Wales 2113, Australia
Phone: 61-2-9878-6377
Fax: 61-2-9878-6981

CHINA

Omron China Co. Ltd.
21F, Beijing East Ocean Centre
No. 24A Jian Guo Men Wai Da Jie
Chao Yang District, Beijing, China 100022
Phone: 86-10-6515-5778/5782
Fax: 86-10-6515-5801/5802

HONG KONG

Omron Electronics Asia Ltd.
Unit 601-10 The Gateway, Tower 2
25 Canton Road
Tsimshatsui, Kowloon, Hong Kong
Phone: 852-2375-3827
Fax: 852-2375-1475

INDIA

Omron Asia-Pacific Pte. Ltd.
No. 59 HemKunt, Opp. Nehru Place
New Delhi, India 110048
Phone: 91-11-623-8431
Fax: 91-11-623-8434

INDONESIA

Omron Asia Pacific PTE Ltd.
Indonesia Representative Office
Danamon Aetna Life Tower, Ste. 1602
JL Jend. Sudirman Kav 45-46
Jakarta 12930, Indonesia
Phone: 62-21-577-0838
Fax: 62-21-577-0840

JAPAN

Omron Corporation
FA Division H.Q.
14F Nissei Building
1-6-3 Osaki
Shinagawa-ku Tokyo
Phone: 03-3779-9038
Fax: 03-3779-9041

KOREA

Omron Korea Co. Ltd.
3F New Seoul Bldg.#618-3
Sin Sa-Dong
Kang Nam-Gu, Seoul, Korea
Phone: 82-2-511-8071
Fax: 82-2-517-9033

MALAYSIA

Omron Electronics Sales & Service
(M) SDN BHD
10th Floor Block B Menara PKNS-PJ
No. 17 Jalan Yong Shook Lin
46050 Petaling Jaya
Selangor Darul Ehsan, Malaysia
Phone: 03-7547323
Fax: 03-7546618

NEW ZEALAND

Omron Electronics Ltd.
65 Boston Road
Private Bag
Symonds Street, Auckland, 92620 New Zealand
Phone: 09-3584400
Fax: 09-3584411

PHILIPPINES

Omron Asia Pacific PTE Ltd.
2/FL. Kings Court II Bldg.
2129 Pasong Tamo St.
Makati City, Metro Manila, Philippines 1231
Phone: 63-2-811-2831/2839
Fax: 63-2-811-2582

SHANGHAI

Omron Automation System Co., Ltd.
500 Omron Road, Block No. 77
JinQiao Export Processing District
Pudong New Area, Shanghai 201206
Phone: 86-21-5854-1712/2080/1064
Fax: 86-21-5854-2658/0123

SINGAPORE

Omron Asia Pacific PTE Ltd.
83 Clemenceau Ave. #11-01
UE Square Singapore 239920
Phone: 65-835-3011
Fax: 65-835-2711

TAIWAN

Omron Taiwan Electronics Inc.
6F, Home Young Bldg., No. 363
Fu-Shing N. Road
Taipei, Taiwan, R.O.C.
Phone: 886-2-7153331
Fax: 886-2-7126712

THAILAND

Omron Electronics Co. Ltd.
Rasa Tower, 20th Floor
555 Phaholyothin Road
Chatuchak, Bangkok 10900, Thailand
Phone: 02-9370500
Fax: 02-9370501

VIETNAM

Omron Asia Pacific PTE Ltd.
Hanoi Representative Office
6th Floor, VINACONEX Building
2 Lang Ha, Hanoi, Vietnam
Phone: 84-4-8313121
Fax: 84-4-8313122



OMRON ELECTRONICS LLC

1 Commerce Drive
Schaumburg, IL 60173 USA
800.55.OMRON (66766)

OMRON CANADA, INC.

885 Milner Avenue
Scarborough, Ontario M1B 5V8
416.286.6465

OMRON ON-LINE

Global - <http://www.omron.com>
USA - <http://www.omron.com/oei>
Canada - <http://www.omron.com/oci>

For Distributor Locations or Product Information, Call:

800.55.OMRON or 847.843.7900

UNITED STATES REGIONAL SALES OFFICES

Northeast	Boston, MA	508.303.8880
East	Philadelphia, PA	610.524.1897
Southeast	Atlanta, GA	770.798.6780
Central	Cincinnati, OH	513.469.6766
Midwest	Chicago, IL	847.843.7910
Southwest	Dallas, TX	972.871.2166
West	Los Angeles, CA	714.621.3455

CANADA REGIONAL SALES OFFICES

Ontario	Toronto	416.286.6465
	Kitchener	519.896.1144
	Kingston	613.376.3968
Quebec	Montreal	514.636.6676
British Columbia	Vancouver	604.522.8855
Alberta	Edmonton	403.440.0818
	Calgary	403.257.3095

BRAZIL SALES OFFICE

Sao Paulo 55.11.5564.6488

ARGENTINA SALES OFFICE

Cono Sur 54.114.787.1129

MEXICO SALES OFFICE - UNITED STATES

Florida 954.227.2121

MEXICO SALES OFFICE - MEXICO

Mexico, D.F. 555.534.1195 **Monterrey, N.L.** 818.377.4281

Visit our website for more information on these other Advanced Automation products from Omron



Programmable Controllers – Control Problem? Omron leads the industry in controller technology. Producing advanced machines of all sizes from micro to large with varying power, I/O, communications, and processing speed options.



Industrial Networking – Omron is a founding member of Open DeviceNet Vendor's Association (ODVA), offering the broadest selection of masters, slaves, specialty products and accessories for DeviceNet available from a single supplier.



Servo Motors and Drives – Omron's W-Series servo motors and drives deliver precise control, maintaining the highest resolution control at very high speeds. Their wide power range (up to 5.5 kW) provides maximum flexibility with easy set up.