

Product Specification

NHD-240128WG-BTMI-VZ#

Graphic Liquid Crystal Display Module

NHD-	Newhaven Display
240128-	240 x 128 Pixels
WG-	Display Type: Graphic
B-	Model
T-	White LED Backlight
M-	STN (-) Blue
I-	Transmissive, 6:00 Optimal View, Wide Temperature
VZ#-	Built-in Negative Voltage

Table of Contents

Document Revision History	2
Functions and Features	2
Mechanical Drawing	3
Pin Description	4
Electrical Characteristics	5
Optical Characteristics	5
Controller Information	5
Table of Commands	6
Timing Characteristics	7
Built-in Font Table	8
Example Code	9
Quality Information	10

Additional Resources

- **Support Forum:** <http://www.nhdforum.newhavendisplay.com>
- **Github:** <https://github.com/newhavendisplay>
- **Example Code:** https://www.newhavendisplay.com/example_code.html
- **Knowledge Center:** https://www.newhavendisplay.com/knowledge_center.html
- **Quality Center:** https://www.newhavendisplay.com/quality_center.html
- **Precautions for using LCDs/LCMs:** <https://www.newhavendisplay.com/specs/precautions.pdf>
- **Warranty / Terms & Conditions:** <https://www.newhavendisplay.com/terms.html>



Document Revision History

Revision	Date	Description	Changed By
0	3/13/2009	Initial Release	-
1	4/26/2010	User guide reformat	BE
2	3/3/2011	Electrical characteristics updated	AK
3	4/29/2011	Pin description updated	AK
4	4/29/2014	Mechanical drawing updated	ML
5	5/14/2014	Electrical characteristics updated	ML
6	11/17/16	Mechanical Drawing & Electrical Characteristics Updated	SB
7	1/8/19	Backlight Characteristics Updated	SB
8	9/20/19	Updated Controller Link	AS
9	6/23/20	Updated Logic Voltages, Quality Information	AS
10	3/3/21	Added MIN Backlight Current	AS
11	5/17/21	Electrical, Optical & IC Updated	ZP
12	8/16/21	2D Mechanical Drawing Updated	ZP

Functions and Features

- 240 x 128 pixels
- Built-in RA6963N1 controller
- +5.0V power supply
- 1/128 duty

Mechanical Drawing

SYMBOL	REVISION	DATE

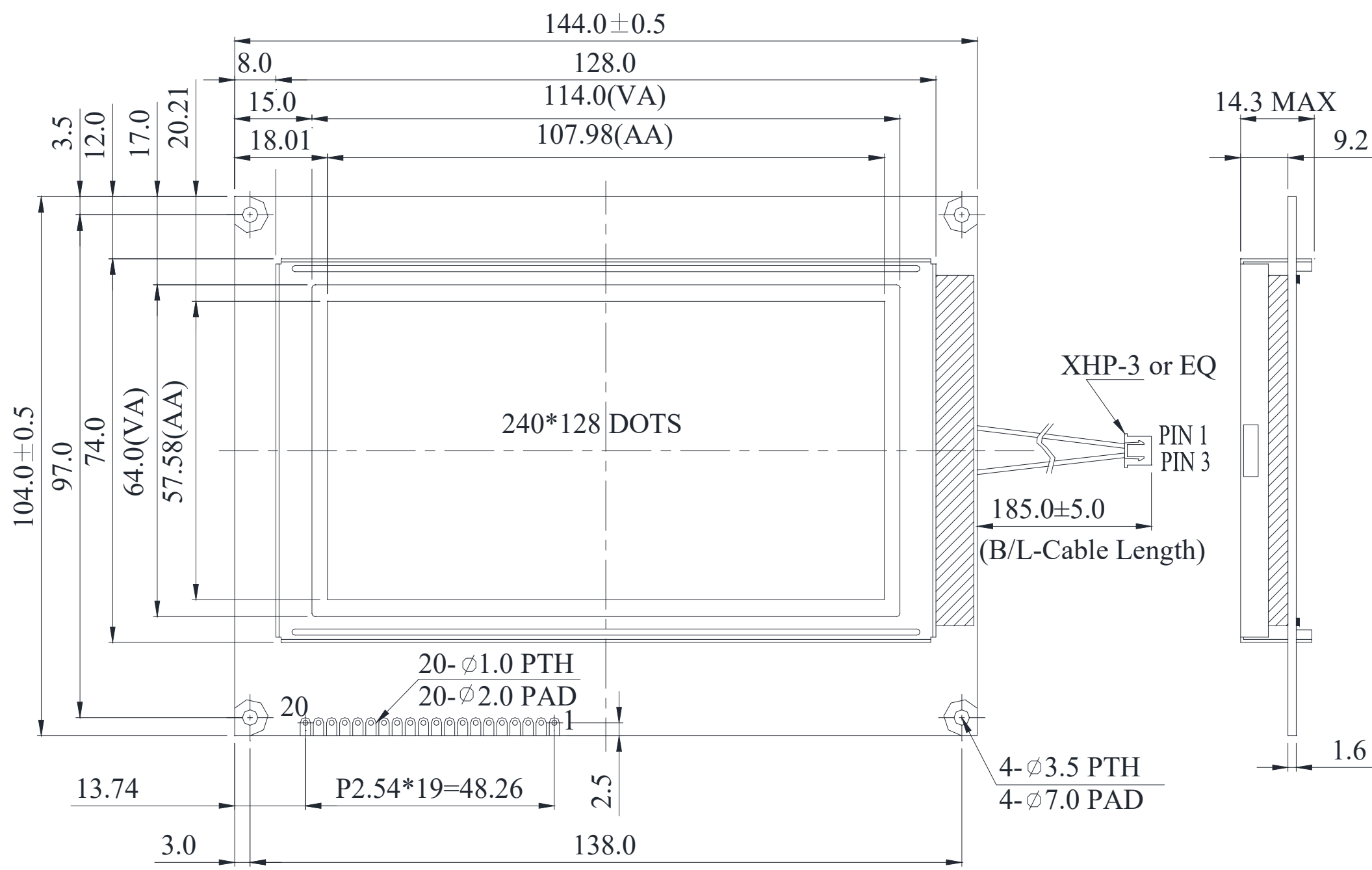

Pin Assignment

PIN NO.	SYMBOL
1	Vss
2	Vdd
3	Vo
4	C/D
5	RD
6	WR
7	DB0
8	DB1
9	DB2
10	DB3
11	DB4
12	DB5
13	DB6
14	DB7
15	CE
16	RESET
17	Vee
18	MD2
19	FS1
20	NC

- Notes:**
1. Driver: 1/128 Duty
 2. Voltage: 5.0V VDD, 19.5V VLCD
 3. Display Mode: STN Negative / Blue / Transmissive
 4. Optimal View: 6:00
 5. Backlight: White LED
 6. Driver IC: RA6963N1

Standard Tolerance: (Unless otherwise specified) Linear: ±0.3mm		
	Drawing/Part Number: NHD-240128WG-BTMI-VZ#	Revision: 1A
Unless otherwise specified: • Dimensions are in Millimeters • Third Angle Projection	Drawn By: Z.Palrang	Approved By: Z.Palrang
	Drawn Date: 08/16/2021	Approved Date: 08/16/2021
Do Not Scale Drawing		Sheet 1 of 1
This drawing is solely the property of Newhaven Display International, Inc. The information it contains is not to be disclosed, reproduced or copied in whole or part without written approval from Newhaven Display.		

Pin Description and Wiring Diagram

Pin No.	Symbol	External Connection	Function Description
1	VSS	Power Supply	Ground
2	VDD	Power Supply	Supply Voltage for Logic (+5.0V)
3	V0	Adj. Power Supply	Supply Voltage for Contrast (approx. -14.5V)
4	C/D	MPU	Command/Data selection: '1' = Command, '0' = Data
5	/RD	MPU	Active LOW Read signal
6	/WR	MPU	Active LOW Write signal
7-14	DB0-DB7	MPU	8-bit bi-directional data bus
15	/CE	MPU	Active LOW Chip Enable signal
16	/RESET	MPU	Active LOW Reset signal
17	VEE	Power Supply	Negative Voltage output (-16V)
18	MD2	MPU	Display size signal: '1' = 32 columns, '0' = 40 columns
19	FS1	MPU	Font Selection: '1' = 6x8, '0' = 8x8
20	NC	-	No Connect
A	LED+	Power Supply	Backlight Anode (60 mA @ 3.5V)
K	LED-	Power Supply	Backlight Cathode (Ground)

Recommended LCD connector: 2.54mm pitch pins

Backlight connector: - **Mates with:** -

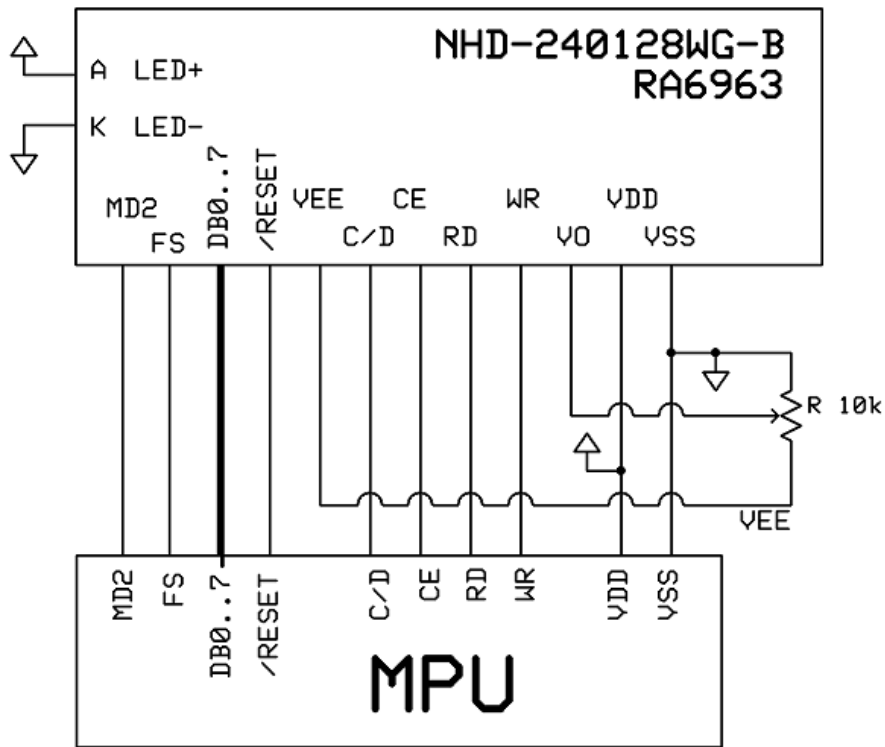

Electrical Characteristics

Item	Symbol	Condition	Min.	Typ.	Max.	Unit
Operating Temperature Range	T _{OP}	Absolute Max	-20	-	+70	°C
Storage Temperature Range	T _{ST}	Absolute Max	-30	-	+80	°C
Supply Voltage	V _{DD}	-	4.5	5.0	5.5	V
Supply Current	I _{DD}	V _{DD} = 5.0V	12	25	55	mA
Supply for LCD (contrast)	V _{LCD}	T _{OP} = 25°C	18.9	19.5	20.1	V
"H" Level input	V _{IH}	-	0.8 * V _{DD}	-	V _{DD}	V
"L" Level input	V _{IL}	-	V _{SS}	-	0.15 * V _{DD}	V
"H" Level output	V _{OH}	-	V _{DD} - 0.3	-	V _{DD}	V
"L" Level output	V _{OL}	-	V _{SS}	-	0.3	V
Backlight Supply Current	I _{LED}	-	45	60	85	mA
Backlight Supply Voltage	V _{LED}	I _{LED} = 60 mA	3.4	3.5	3.6	V

*The LED of the backlight is driven by current drain; drive voltage is for reference only. Drive voltage must be selected to ensure backlight current drain is below MAX level stated.

Optical Characteristics

Item		Symbol	Condition	Min.	Typ.	Max.	Unit
Optimal Viewing Angles	Top	φY+	CR ≥ 2	0	-	20	°
	Bottom	φY-		0	-	40	°
	Left	θX-		0	-	30	°
	Right	θX+		0	-	30	°
Contrast Ratio		CR	-	2	3	-	-
Response Time	Rise	T _R	T _{OP} = 25°C	-	200	300	ms
	Fall	T _F		-	250	350	ms

Controller Information

Built-in RA6963N1.

Please download specification at https://www.newhavendisplay.com/resources_dataFiles/datasheets/LCDs/RA6963.pdf

Table of Commands

Command	Code	D1	D2	Function
Registers Setting	00100001	X address	Y address	Set cursor pointer
	00100010	Data	00h	Set Offset Register
	00100100	Low address	High address	Set Address pointer
Set Control Word	01000000	Low address	High address	Set Text Home Address
	01000001	Columns	00h	Set Text Area
	01000010	Low address	High address	Set Graphic Home Address
	01000011	Columns	00h	Set Graphic Area
Mode Set	1000X000	--	--	OR mode
	1000X001	--	--	EXOR mode
	1000X011	--	--	AND mode
	1000X100	--	--	Text Attribute mode
	10000XXX	--	--	Internal CG ROM mode
	10001XXX	--	--	External CG RAM mode
Display Mode	10010000	--	--	Display off
	1001XX10	--	--	Cursor on, blink off
	1001XX11	--	--	Cursor on, blink on
	100101XX	--	--	Text on, graphic off
	100110XX	--	--	Text off, graphic on
	100111XX	--	--	Text on, graphic on
Cursor Pattern Select	10100000	--	--	1-line cursor
	10100001	--	--	2-line cursor
	10100010	--	--	3-line cursor
	10100011	--	--	4-line cursor
	10100100	--	--	5-line cursor
	10100101	--	--	6-line cursor
	10100110	--	--	7-line cursor
	10100111	--	--	8-line cursor
Data auto Read/Write	10110000	--	--	Set Data Auto Write
	10110001	--	--	Set Data Auto Read
	10110010	--	--	Auto Reset
Data Read/Write	11000000	Data	--	Data Write and Increment ADP
	11000001	--	--	Data Read and Increment ADP
	11000010	Data	--	Data Write and Decrement ADP
	11000011	--	--	Data Read and Decrement ADP
	11000100	Data	--	Data Write and Non-variable ADP
	11000101	--	--	Data Read and Non-variable ADP
Screen Peek	11100000	--	--	Screen Peek
Screen Copy	11101000			Screen Copy
Bit Set/Reset	11110XXX	--	--	Bit Reset
	11111XXX	--	--	Bit Set
	1111X000	--	--	Bit 0 (LSB)
	1111X001	--	--	Bit 1
	1111X010	--	--	Bit 2
	1111X011	--	--	Bit 3
	1111X100	--	--	Bit 4
	1111X101	--	--	Bit 5
	1111X110	--	--	Bit 6
	1111X111	--	--	Bit 7 (MSB)

Timing Characteristics

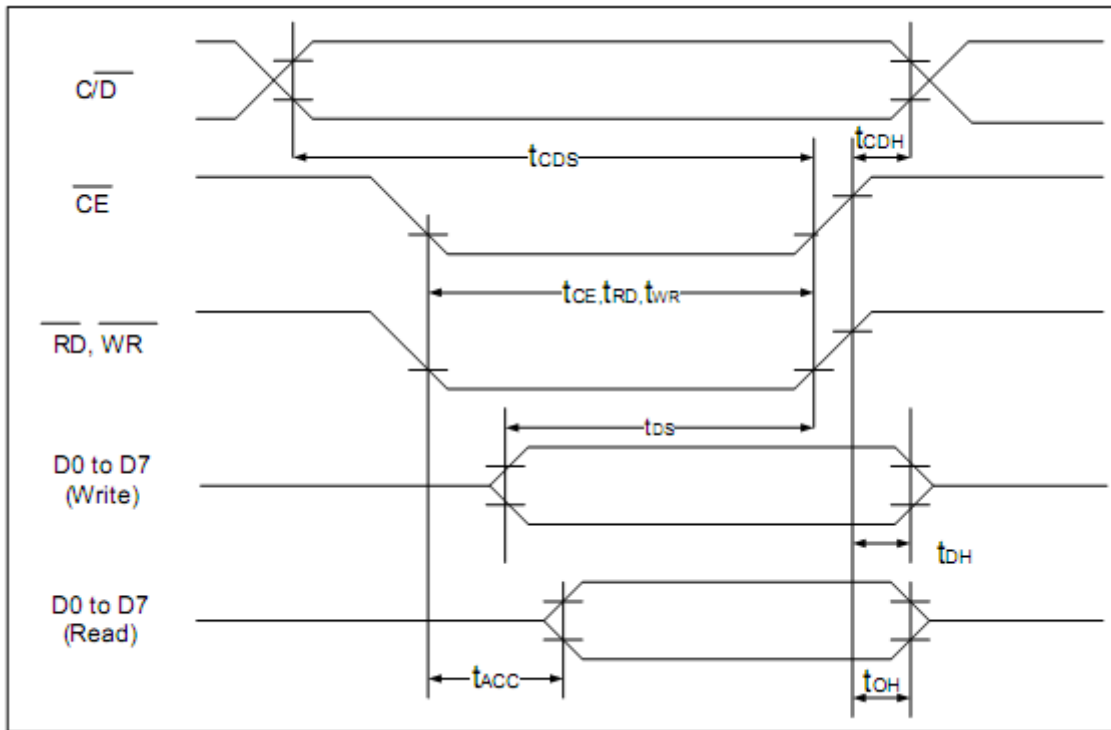

($V_{DD}=+5V\pm 5\%, GND=0V, T_a = -20$ to $+70^\circ C$)

Item	Symbol	Test Conditions	Min.	Max.	Unit
$\overline{C/D}$ Set Up Time	t_{CDS}	--	100	--	ns
$\overline{C/D}$ Hold Time	t_{CDH}	--	10	--	ns
$\overline{CE}, \overline{RD}, \overline{WR}$ Pulse Width	t_{CE}, t_{RD}, t_{WR}	--	80	--	ns
Data Set Up Time	t_{DS}	--	80	--	ns
Data Hold Time	t_{DH}	--	40	--	ns
Access Time	t_{ACC}	--	--	150	ns
Output Hold Time	t_{OH}	--	10	50	ns

Built-in Font Table

LSB MSB	0	1	2	3	4	5	6	7	8	9	A	B	C	D	E	F
0		!	"	#	\$	%	&	'	()	*	+	,	-	.	/
1	0	1	2	3	4	5	6	7	8	9	:	;	<	=	>	?
2	A	B	C	D	E	F	G	H	I	J	K	L	M	N	O	
3	P	Q	R	S	T	U	U	W	X	Y	Z	[\]	^	_
4	`	a	b	c	d	e	f	g	h	i	j	k	l	m	n	o
5	p	q	r	s	t	u	v	w	x	y	z	{		}	~	
6	Q	Ü	È	Å	ä	å	Ä	Q	È	È	È	ì	ì	ì	Ä	Ä
7	È	Æ	Æ	ö	ö	ö	Ü	Ü	Ü	Ü	Ø	Ø	£	¥	℞	ƒ

Example Program Code

```
//-----
Sub Writecom
P1 = A                'move data to port 1
Set P3.0              'set I/D for instruction
Reset P3.1            'reset /CS
Reset P3.4            'reset /WR
Set P3.1              'set /CS
Set P3.4              'set /WR
End Sub

Sub Writedata
P1 = A                'move data to port 1
Reset P3.0            'reset I/D for instruction
Reset P3.1
Reset P3.4            'toggle /CS and /WR
Set P3.1
Set P3.4
End Sub

//-----
Sub Init
Set P3.6
Set P3.7
Reset P3.3            'reset FS
A = &H00
Call Writedata
Call Writedata        'text address = 0000h
A = &H40
Call Writecom         'text home address set
A = &H00
Call Writedata
A = &H40              'graphic home address = 4000h
Call Writedata
A = &H42
Call Writecom         'graphic home address set
A = &H1E
Call Writedata
A = &H00              'text area address = 001Eh
Call Writedata
A = &H41
Call Writecom         'text area control set
A = &H1E
Call Writedata
A = &H00              'graphic area = 001Eh
Call Writedata
A = &H43
Call Writecom         'graphic area control set
A = &H80
Call Writecom         'set display mode
End Sub
```



Quality Information

Test Item	Content of Test	Test Condition	Note
High Temperature storage	Endurance test applying the high storage temperature for a long time.	+80°C, 200hrs	2
Low Temperature storage	Endurance test applying the low storage temperature for a long time.	-30°C, 200hrs	1,2
High Temperature Operation	Endurance test applying the electric stress (voltage & current) and the high thermal stress for a long time.	+70°C, 200hrs	2
Low Temperature Operation	Endurance test applying the electric stress (voltage & current) and the low thermal stress for a long time.	-20°C, 200hrs	1,2
High Temperature / Humidity Operation	Endurance test applying the electric stress (voltage & current) and the high thermal with high humidity stress for a long time.	+60°C, 90% RH, 96hrs	1,2
Thermal Shock resistance	Endurance test applying the electric stress (voltage & current) during a cycle of low and high thermal stress.	-20°C, 30min -> 25°C, 5min -> 70°C, 30min = 1 cycle 10 cycles	
Vibration test	Endurance test applying vibration to simulate transportation and use.	10-55Hz, 1.5mm amplitude. 60 sec in each of 3 directions X,Y,Z For 15 minutes	3
Static electricity test	Endurance test applying electric static discharge.	Air: ±800V 150pF/330Ω, 5 Times	
		Contact: ±600V 150pF/330Ω, 5 Times	

Note 1: No condensation to be observed.

Note 2: Conducted after 4 hours of storage at 25°C, 0%RH.

Note 3: Test performed on product itself, not inside a container.