

**Product Specification**

---

# NHD-1.8-128160EF-CSXN#-F

## TFT (Thin-Film Transistor) Liquid Crystal Display Module

<b>NHD-</b>	Newhaven Display
<b>1.8-</b>	1.8" Diagonal Size
<b>128160-</b>	128 x 160 pixels (Portrait Mode)
<b>EF-</b>	Model
<b>C-</b>	Built-in Controller
<b>S-</b>	Sunlight Readable
<b>X-</b>	TFT
<b>N-</b>	TN, 6:00 Optimal View, Wide Temperature
<b>#-</b>	RoHS Compliant
<b>F-</b>	FFC ZIF Connection Style

## Table of Contents

Document Revision History.....	2
Mechanical Drawing .....	3
Pin Description .....	4
Wiring Diagram .....	4
Electrical Characteristics .....	5
Optical Characteristics .....	5
Controller Information.....	5
Table of commands .....	6
Timing Characteristics.....	6
Example Program Code.....	9
Quality Information .....	10

---

## Additional Resources

- **Support Forum:** <https://support.newhavendisplay.com/hc/en-us/community/topics>
- **GitHub:** <https://github.com/newhavendisplay>
- **Example Code:** <https://support.newhavendisplay.com/hc/en-us/categories/4409527834135-Example-Code/>
- **Knowledge Center:** [https://www.newhavendisplay.com/knowledge\\_center.html](https://www.newhavendisplay.com/knowledge_center.html)
- **Quality Center:** [https://www.newhavendisplay.com/quality\\_center.html](https://www.newhavendisplay.com/quality_center.html)
- **Precautions for using LCDs/LCMs:** <https://www.newhavendisplay.com/specs/precautions.pdf>
- **Warranty / Terms & Conditions:** <https://www.newhavendisplay.com/terms.html>



## Document Revision History

Revision	Date	Description	Changed By
0	05/21/2015	Initial Release	AK
1	11/05/2015	Datasheet Reformat	SB
2	02/26/2016	Brightness, Supply Current, and Viewing Direction Updated, Added Backlight Lifetime	SB
3	12/30/2016	Modified Viewing Angles	SB
4	03/08/2021	Updated Silkscreen on FPC, Footnote for Backlight Drive Conditions, Optical Characteristics & Quality Information	AS
5	08/04/2023	Timing Characteristics and Table of Commands Updated	KL
6	09/03/2023	V <sub>DD</sub> /IOV <sub>DD</sub> Supply Voltage changed from 2.8V to 3.0V (Typ.) Mechanical Drawing Updated	KL

# Mechanical Drawing

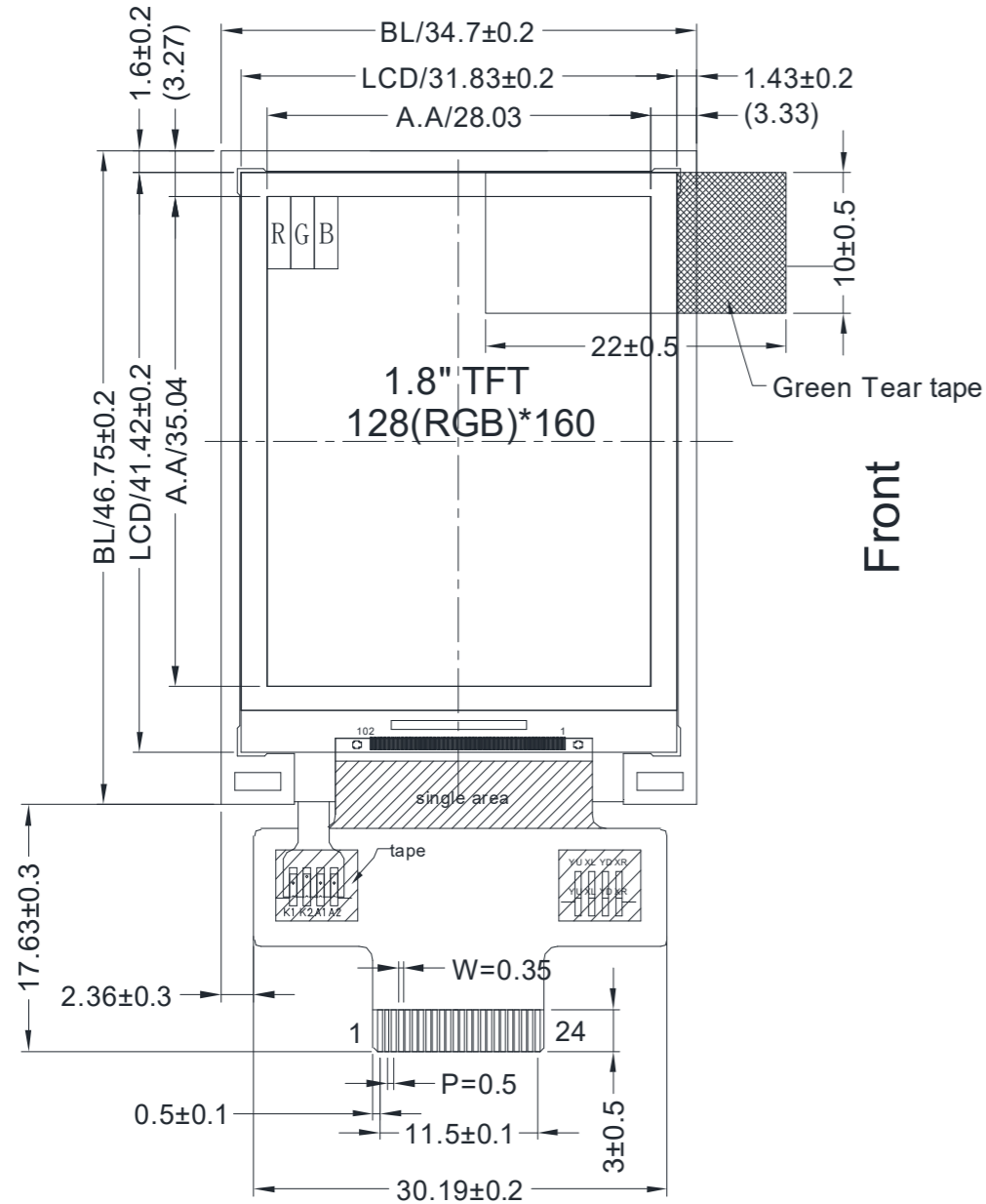

Front

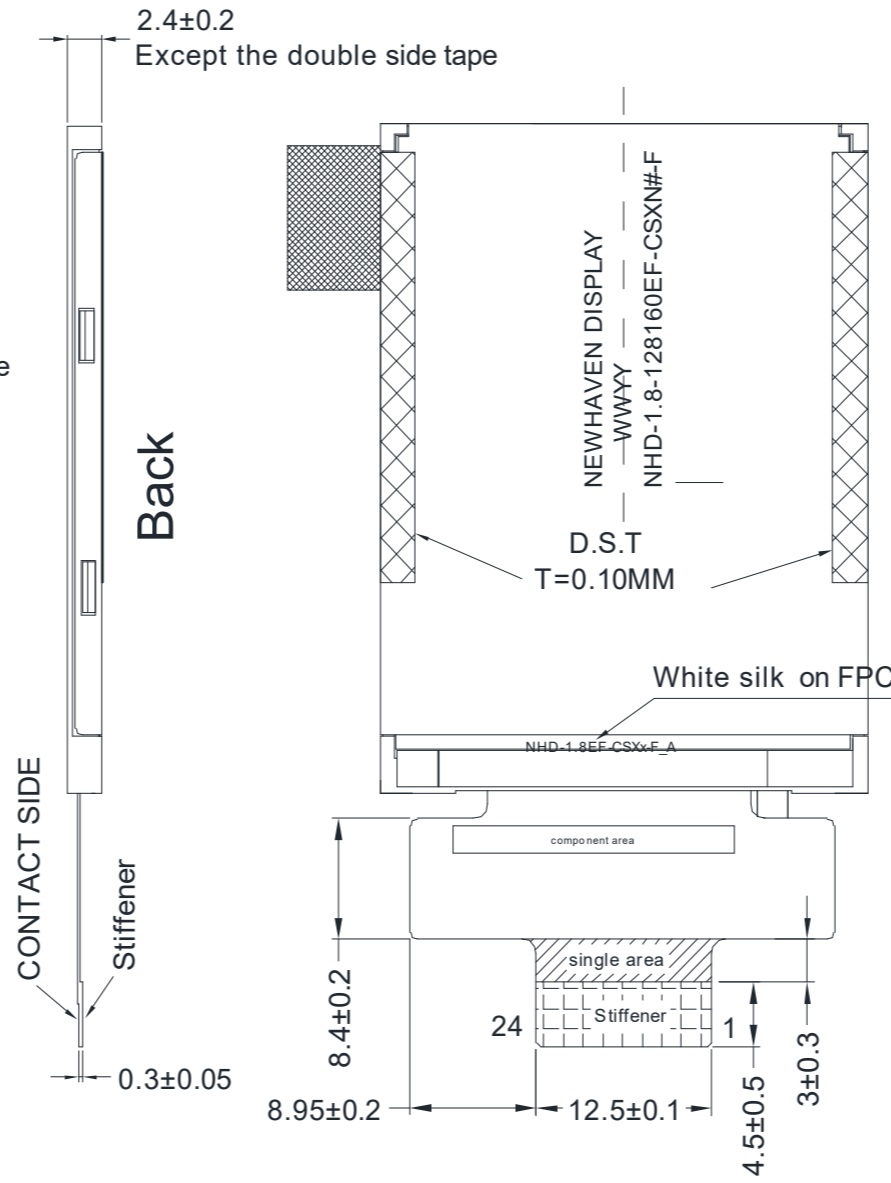

Back

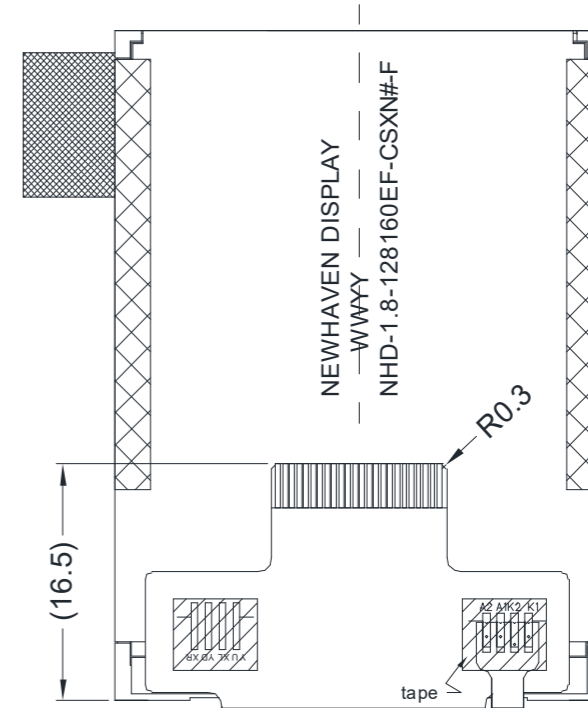

## TFT Pinout:

Pin No.	Symbol
1	GND
2	IOVDD
3	VDD
4	/CS
5	/RST
6	D/C
7	/WR
8	/RD
9	DB0
10	DB1
11	DB2
12	DB3
13	DB4
14	DB5
15	DB6
16	DB7
17	LED-A
18	LED-K1
19	LED-K2
20	GND
21	NC
22	NC
23	NC
24	NC

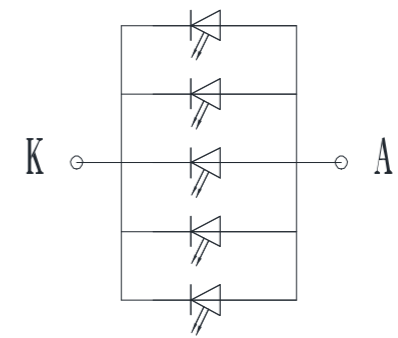

Product Description: 1.8 128x160 Sunlight Readable TFT

1. Driver IC: ILI9163V
2. Interface: 8-bit Parallel
3. Power Requirement: 3.0V TFT, 3.2V/100mA Backlight
4. Optical Features: Normally White, Transmissive, Anti-Glare, 1000cd/m<sup>2</sup>
5. Recommended FFC Connector: 24pin 0.5mm pitch; Molex 52435-2471

<b>Standard Tolerance:</b> (Unless otherwise specified)  Linear: ±0.3mm		
	Drawing/Part Number: <b>NHD-1.8-128160EF-CSXN#-F</b>	Revision: -
<b>Unless otherwise specified:</b> • Dimensions are in Millimeters • Third Angle Projection	Drawn By: K. Lewis	Approved By: K. Lewis
	Drawn Date: 09/03/2023	Approved Date: 09/03/2023
This drawing is solely the property of Newhaven Display International, Inc. The information it contains is not to be disclosed, reproduced or copied in whole or part without written approval from Newhaven Display.		

## Pin Description

Pin No.	Symbol	External Connection	Function Description
1	GND	Power Supply	Ground
2	IOV <sub>DD</sub>	Power Supply	Supply Voltage for Logic (3.0V) – Can be tied to VDD
3	V <sub>DD</sub>	Power Supply	Supply Voltage for LCD (3.0V)
4	/CS	MPU	Active LOW Chip Select signal
5	/RST	MPU	Active LOW Reset signal
6	D/C	MPU	Data / Command selection: '1' = Data ; '0' = Command
7	/WR	MPU	Active LOW Write signal
8	/RD	MPU	Active LOW Read signal
9	DB0	MPU	8-bit bi-directional data bus
10	DB1	MPU	
11	DB2	MPU	
12	DB3	MPU	
13	DB4	MPU	
14	DB5	MPU	
15	DB6	MPU	
16	DB7	MPU	
17	LED-A	Power Supply	Backlight Anode (3.2V)
18	LED-K1	Power Supply	Backlight Cathode (GND)
19	LED-K2	Power Supply	Backlight Cathode (GND)
20	GND	Power Supply	Ground
21	NC	-	No Connect
22	NC	-	No Connect
23	NC	-	No Connect
24	NC	-	No Connect

LCD connector: 24pin 0.5mm FFC connector. Molex P/N: 52435-2471

## Wiring Diagram

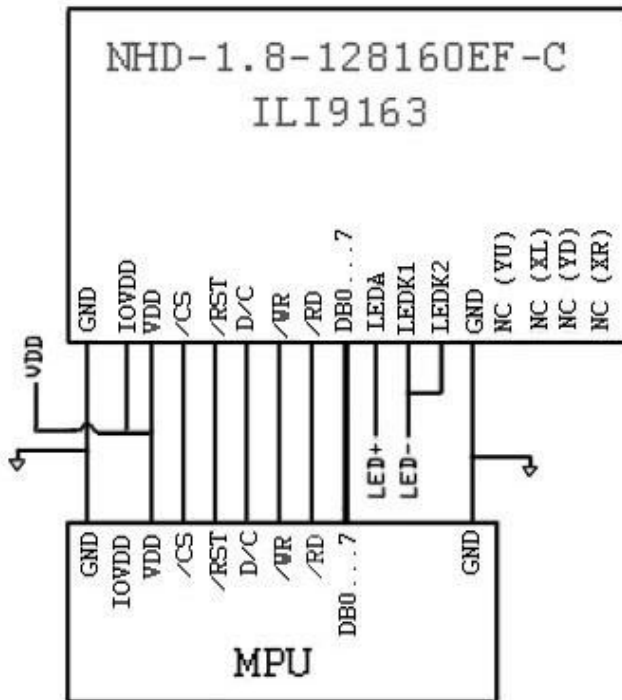

## Electrical Characteristics

Item	Symbol	Condition	Min.	Typ.	Max.	Unit
Operating Temperature Range	T <sub>OP</sub>	Absolute Max	-20	-	+70	°C
Storage Temperature Range	T <sub>ST</sub>	Absolute Max	-30	-	+80	°C
Supply Voltage for Logic	IOV <sub>DD</sub>	-	1.65	3.0	3.3	V
Supply Voltage for LCD	V <sub>DD</sub>	-	2.5	3.0	3.3	V
Supply Current	I <sub>DD</sub>	V <sub>DD</sub> = 3.0V	1	3	5	mA
"H" Level input	V <sub>IH</sub>	-	0.7*IOV <sub>DD</sub>	-	IOV <sub>DD</sub>	V
"L" Level input	V <sub>IL</sub>	-	GND	-	0.3*IOV <sub>DD</sub>	V
"H" Level output	V <sub>OH</sub>	-	0.8*IOV <sub>DD</sub>	-	IOV <sub>DD</sub>	V
"L" Level output	V <sub>OL</sub>	-	GND	-	0.2*IOV <sub>DD</sub>	V
Backlight Supply Voltage	V <sub>LED</sub>	I <sub>LED</sub> = 100mA	3.0	3.2	3.4	V
Backlight Supply Current	I <sub>LED</sub>	-	80	100	110	mA
Backlight Lifetime*	-	I <sub>LED</sub> = 100mA T <sub>OP</sub> = 25°C	20,000	50,000	-	Hrs.

\*Backlight lifetime is rated as Hours until **half-brightness**, under normal operating conditions. The LED of the backlight is driven by current drain; drive voltage is for reference only. Drive voltage must be selected to ensure backlight current drain is below MAX level stated

## Optical Characteristics

Item	Symbol	Condition	Min.	Typ.	Max.	Unit	
Optimal Viewing Angles	Top	CR ≥ 10	-	60	-	°	
	Bottom		-	40	-	°	
	Left		-	60	-	°	
	Right		-	60	-	°	
Contrast Ratio	CR	-	400	500	-	-	
Luminance	L <sub>V</sub>	I <sub>LED</sub> =100mA	800	1000	-	cd/m <sup>2</sup>	
Response Time	Rise + Fall	T <sub>R</sub> +T <sub>F</sub>	T <sub>OP</sub> = 25°C	-	8	16	ms

## Controller Information

Built-in ILI9163V Controller: <https://support.newhavendisplay.com/hc/en-us/articles/4414575853079--ILI9163V>



## Table of commands

For Command Table and Descriptions, please see:

[https://support.newhavendisplay.com/hc/en-us/article\\_attachments/4414532035607/ILI9163V.pdf](https://support.newhavendisplay.com/hc/en-us/article_attachments/4414532035607/ILI9163V.pdf)

## Timing Characteristics

### Parallel 8-bit Bus

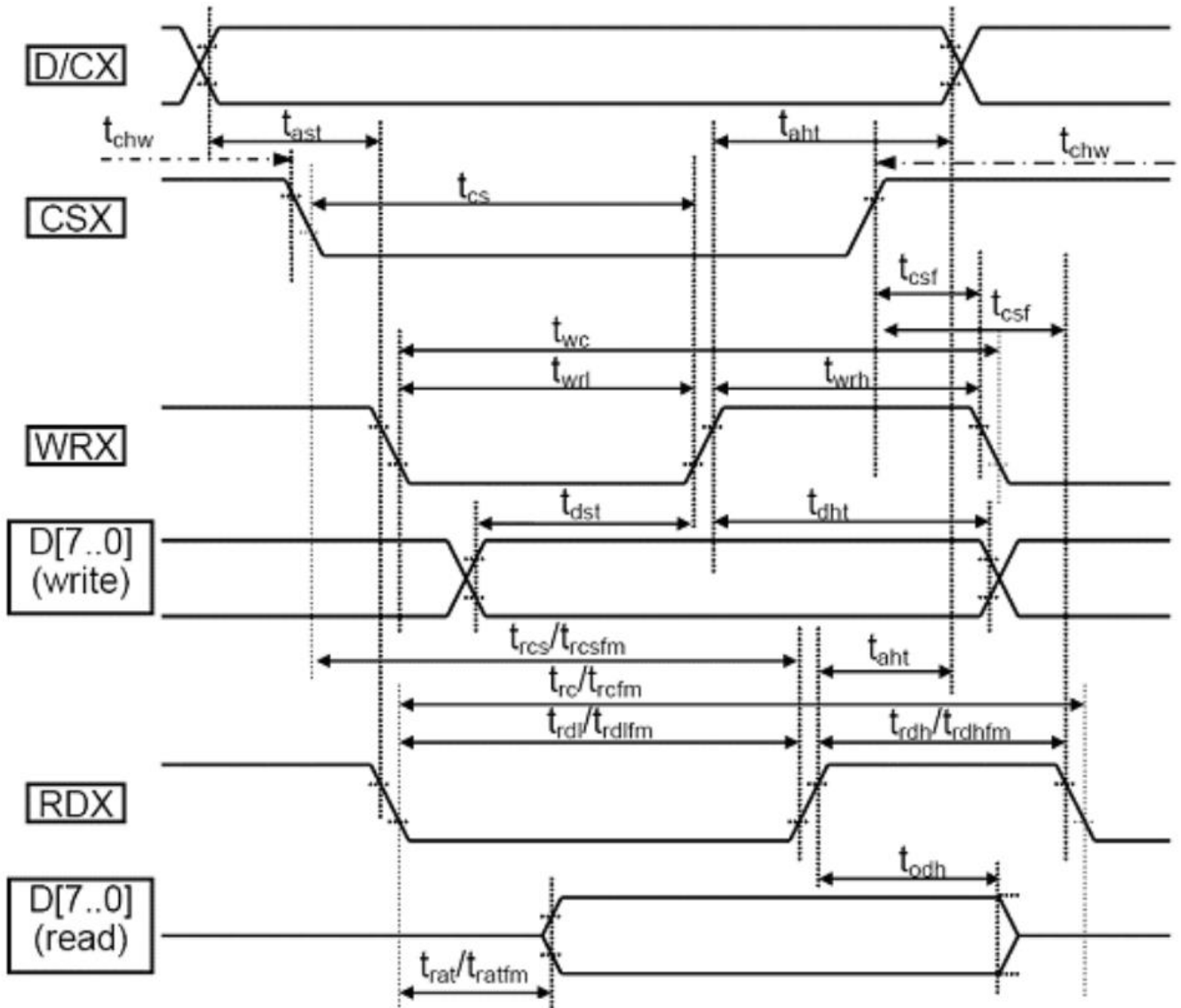

Note: Logic high and low levels are specified as 30% and 70% of VDDI for Input signals.

Signal	Symbol	Parameter	min	max	unit	description
D/CX	tast	Address setup time	0		ns	
	taht	Address hold time(Write/Read)	10		ns	
CSX	tchw	"S""H" Pulse Width	0		ns	
	tcs	Chip Select setup time (Write)	10		ns	
	trcs	Chip Select setup time (Read ID)	45		ns	
	trcsfm	Chip Select setup time (Read FM)	355		ns	
	tcsf	Chip Select Wait time(Write/read)	10		ns	
WRX	twc	Write cycle	66		ns	
	twrh	Control pulse H duration	15		ns	
	twrl	Control pulse L duration	15		ns	
RDX	trc	Read cycle (ID)	160		ns	When read ID data
	trdh	Control pulse H duration(ID)	90		ns	
	trdl	Control pulse L duration(ID)	45		ns	
RDX	trcfm	Read cycle (FM)	450		ns	When read from frame memory
	trdhfm	Control pulse H duration (FM)	90		ns	
	trdlfm	Control pulse L duration (FM)	355		ns	
D[17..0]	tdst	Data setup time	10		ns	For maximum CL = 30pF
	tdht	Data hold time	10		ns	
	trat	Read access time (ID)		40	ns	For minimum CL = 8pF
	tratfm	Read access time (FM)		340	ns	
	todh	Output disable time	20	80	ns	

Note 1: VDDI 1.65 to 3.3V, VDD=2.6 to 3.3V, AGND=GND=0V, Ta=-30 to 70 °C (to +85°C no damage)

Note 2: This input signal rise time and fall time (tr, tf) is specified at 15 ns or less. Logic high and low levels are specified as 30% and 70% of VDDI for input signals



## Reset Timing

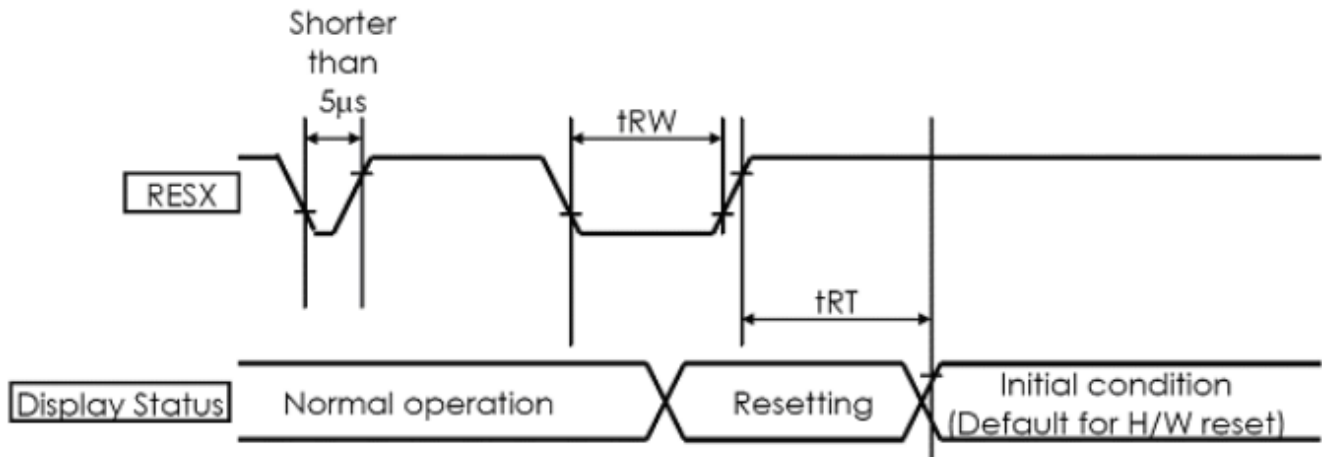

(VSS=0V, VDDI=1.65V to 1.95V, VCI=2.6V to 2.9V, Ta = -30 to 70°C)

Symbol	Parameter	Related Pins	MIN	TYP	MAX	Note	Unit
tRESW	*1) Reset low pulse width	RESX	10	-	-	-	µs
tREST	*2) Reset complete width	-	-	-	5	When reset applied during Sleep in mode	ms
		-	-	-	120	When reset applied during Sleep out mode	ms

## Example Program Code

```

void TFT_18E_Init(void)
{
    GPIO_ResetBits(GPIOC, CS1);
    GPIO_SetBits(GPIOC, nRD);
    GPIO_ResetBits(GPIOC, nWR);
    GPIO_WriteBit(GPIOC, RES, Bit_RESET);
    delay(5);
    TFT_delay(10);
    GPIO_WriteBit(GPIOC, RES, Bit_SET);
    delay(100);
    TFT_delay(10);
    TFT_18E_Write_Command(0x11);
    TFT_delay(100);
    TFT_18E_Write_Command(0x26);TFT_18E_Write_Data(0x04);
    TFT_18E_Write_Command(0xF2);TFT_18E_Write_Data(0x00);
    TFT_18E_Write_Command(0xB1);TFT_18E_Write_Data(0x0A);TFT_18E_Write_Data(0x14);
    TFT_18E_Write_Command(0xC0);TFT_18E_Write_Data(0x0A);TFT_18E_Write_Data(0x00);
    TFT_18E_Write_Command(0xC1);TFT_18E_Write_Data(0x02);
    TFT_18E_Write_Command(0xC5);TFT_18E_Write_Data(0x2F);TFT_18E_Write_Data(0x3E);
    TFT_18E_Write_Command(0xC7);TFT_18E_Write_Data(0x40);
    TFT_18E_Write_Command(0x2A);
    TFT_18E_Write_Data(0x00);
    TFT_18E_Write_Data(0x00);
    TFT_18E_Write_Data(0x00);
    TFT_18E_Write_Data(0x7F);
    TFT_18E_Write_Command(0x2B);
    TFT_18E_Write_Data(0x00);
    TFT_18E_Write_Data(0x00);
    TFT_18E_Write_Data(0x00);
    TFT_18E_Write_Data(0x9F);
    TFT_18E_Write_Command(0x36);TFT_18E_Write_Data(0x48);
    TFT_18E_Write_Command(0x3A);TFT_18E_Write_Data(0xC5);
    TFT_18E_Write_Command(0x29);
    TFT_18E_Write_Command(0x2C);
}
/*****/
void TFT_18E_Write_Command(unsigned char command)
{
    GPIO_ResetBits(GPIOC, RS);
    GPIO_Write(GPIOB, command);
    GPIO_ResetBits(GPIOC, nWR);
    GPIO_SetBits(GPIOC, nWR);
}
/*****/
void TFT_18E_Write_Data(unsigned char data1)
{
    GPIO_SetBits(GPIOC, RS);
    GPIO_Write(GPIOB, data1);
    GPIO_ResetBits(GPIOC, nWR);
    GPIO_SetBits(GPIOC, nWR);
}
/*****/

```



## Quality Information

Test Item	Content of Test	Test Condition	Note
High Temperature storage	Endurance test applying the high storage temperature for a long time.	+80°C , 96hrs	2
Low Temperature storage	Endurance test applying the low storage temperature for a long time.	-30°C , 96hrs	1,2
High Temperature Operation	Endurance test applying the electric stress (voltage & current) and the high thermal stress for a long time.	+70°C , 96hrs	2
Low Temperature Operation	Endurance test applying the electric stress (voltage & current) and the low thermal stress for a long time.	-20°C , 96hrs	1,2
High Temperature / Humidity Storage	Endurance test applying the electric stress (voltage & current) and the high thermal with high humidity stress for a long time.	+50°C , 90% RH , 96hrs	1,2
Thermal Shock resistance	Endurance test applying the electric stress (voltage & current) during a cycle of low and high thermal stress.	-20°C 60 min ~ +70°C 60 min, 20 cycles	
Vibration test	Endurance test applying vibration to simulate transportation and use.	10-50Hz , 5G amplitude. 30 min in each of 3 directions X,Y,Z	3
Static electricity test	Endurance test applying electric static discharge.	Air: ±8kV 150pF/330Ω, 5 Times	
		Contact: ±4kV 150pF/330Ω, 5 Times	

**Note 1:** No condensation to be observed.

**Note 2:** Conducted after 4 hours of storage at 25°C, 0%RH.

**Note 3:** Test performed on product itself, not inside a container.