

cUL Recognized to IEC60601-1-8 AMD2:2020

Specifications:

General Melody

Sound Level Category:	Silent	Loud	Loud	Loud
Mode of Operation:	Silent	Low Priority Alarm - 2 beeps repeating every 20 sec	Medium Priority Alarm - 3 beeps repeating every 7.5 sec	High Priority Alarm - 10 beeps repeating every 2.5 seconds
Loudness @ 10cm:	Silent	85 to 95 dB(A) Typ.	85 to 95 dB(A) Typ.	85 to 95 dB(A) Typ.
Frequency:	Silent	150 to 4000 Hz	150 to 4000 Hz	150 to 4000 Hz
Connection:	Connect "+" to "+" & "-" to "-" of Power Supply	Connect "+" to "+" & "-" & Low to "-" of Power Supply	Connect "+" to "+" & "-" & Medium to "-" of Power Supply	Connect "+" to "+" & "-" & High to "-" of Power Supply
Average Current Draw:	<20mA Typ.	<45mA Typ.	<70mA Typ.	<150mA Typ.
Voltage Rating:	2.7 - 5.5 VDC			
Ipk Current*:	400mA			
Housing Material:	Valox (UL94V-0), Octagonal, Black			
Storage Temperature:	-30° to +60° C			
Operating Temperature:	-30° to +55° C			
Weight Typical:	6.0g			
Options:	Please contact factory.			

Dimensions:

Inches [mm]

cUL Recognized

ROHS Compliant

PATENT NUMBER: 7880593

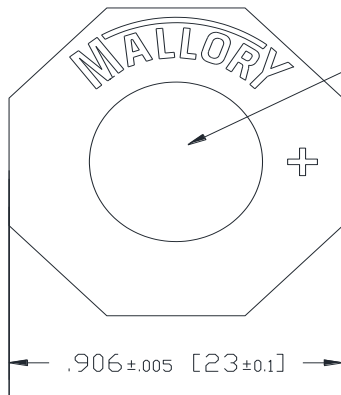

EMISSION HOLE

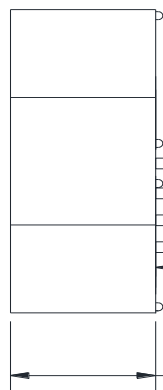
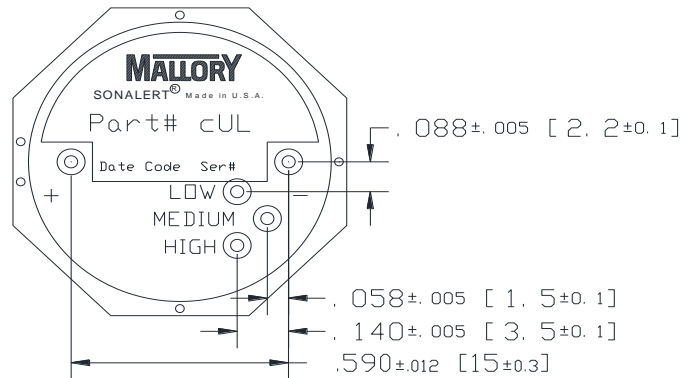

$.031 \pm .002$ [0.8±0.4]
(5 Pins)

$.158 \pm .005$ [4.0±0.1]

$.197 \pm .005$ [5.0±0.1]

$.512 \pm .005$ [13±0.1]

$.082 \pm .005$ [2.1±0.1]

$.079 \pm .005$ [2.0±0.1]

NOTE A:
TERMINALS - .031" DIA. NICKEL/TIN COATED BRASS.

NOTE B:
MOUNTING- INSERT INTO PRINTED CIRCUIT BOARD AND HAND OR MACHINE SOLDER. UNITS ARE SUITABLE FOR WAVE SOLDERING. BOARDS ARE NOT SUITABLE FOR WASH. RECOMMENDED MAXIMUM TEMPERATURE AND TIME DURATION FOR WAVE SOLDERING IS +270°C AND 3 SECONDS RESPECTIVELY.

*Ipk = Instantaneous Peak