

# 10-32 Stud (Shortstop Style) Circuit Breaker

# MRCBP-H Colored Body

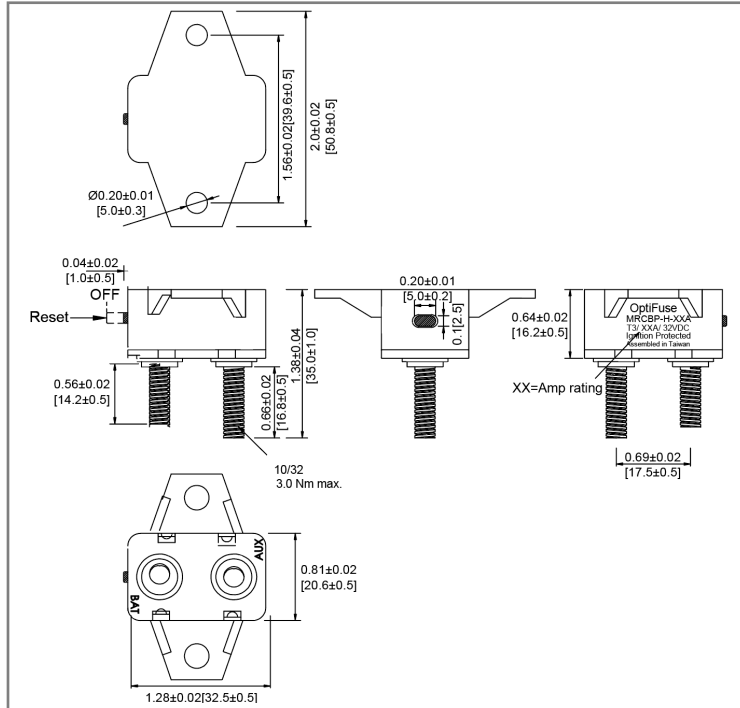

## Mechanical Dimensions: Inches [mm]



## Retail Pack: Inches [mm]

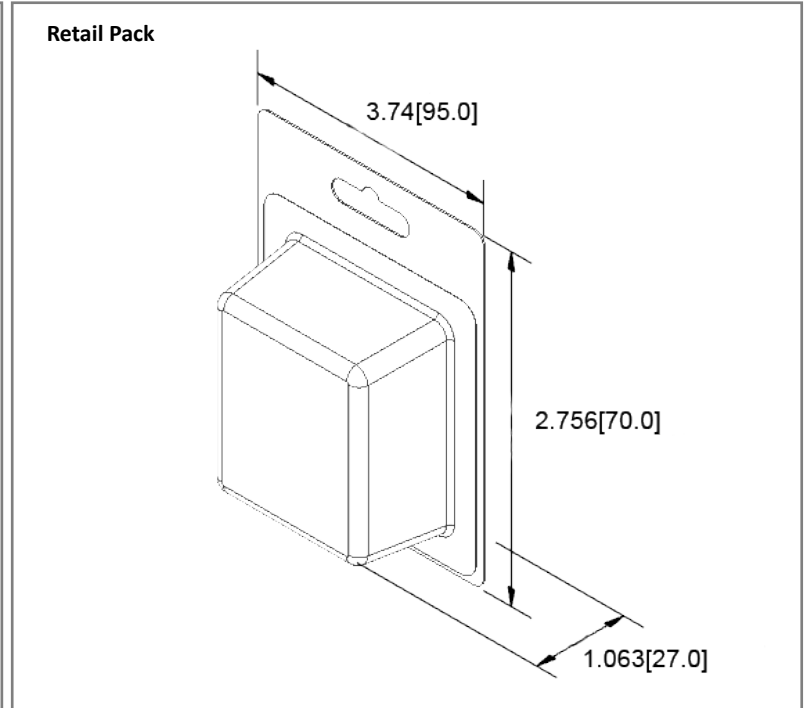

## Part Numbers Information

Amperage	Body Color	Bulk Part #	Retail Pack # Blister Card	Pack Size
10A	Gray	MRCBP-H-10A	MRCBP-H-10A-BP	1
15A	Blue	MRCBP-H-15C	MRCBP-H-15C-BP	1
20A	Yellow	MRCBP-H-20C	MRCBP-H-20C-BP	1
25A	White	MRCBP-H-25C	MRCBP-H-25C-BP	1
30A	Green	MRCBP-H-30C	MRCBP-H-30C-BP	1
40A	Orange	MRCBP-H-40C	MRCBP-H-40C-BP	1
50A	Red	MRCBP-H-50C	MRCBP-H-50C-BP	1

## Electrical Specifications

Voltage Rating	12/24/32VDC
Reset Type	Type III - Manual Reset
Interrupting Rating	4 times rated current
Operation Temperature	-10°C ~ 60°C
Testing	SAE J553

## Material Specifications

Body Material	Thermoplastic (UL94V-0)
Terminals Configuration	Battery – Copper Plate Auxiliary – Zinc Plate
Studs Torque	3.0 ± 0.3 N.m
Mounting Torque	1.0 ± 0.1 N.m
Ignition Protection	SAE J1171   Ingress Protection IP63

**Time vs. Percent of Rated Current**

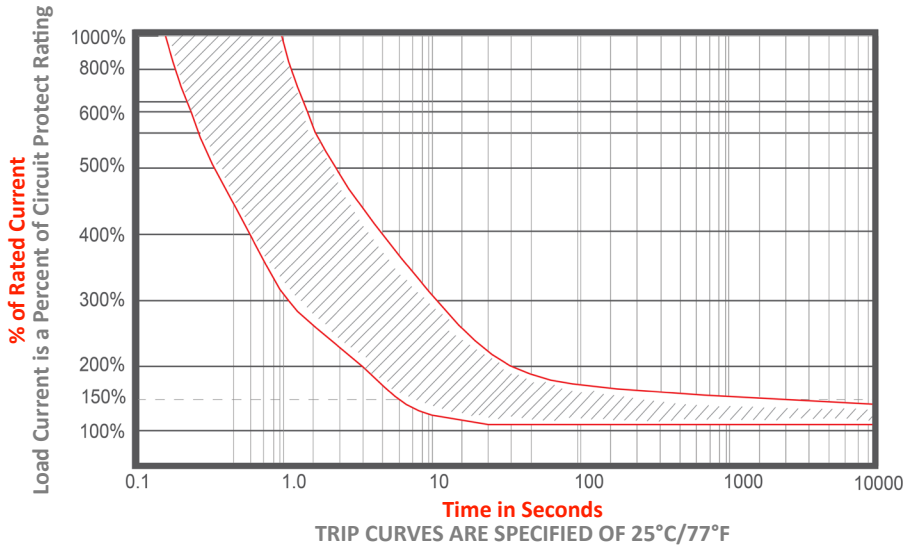

% of Rated Current	Min Trip Time	Max Trip Time
100%	Hold	No Trip
150%		Trip in 1 hr
200%	4.0s	40.0s
300%	1.2s	12.0s
400%	0.6s	5.0s
500%	0.4s	2.8s
600%	0.3s	1.8s

**Temperature Derating Curve**

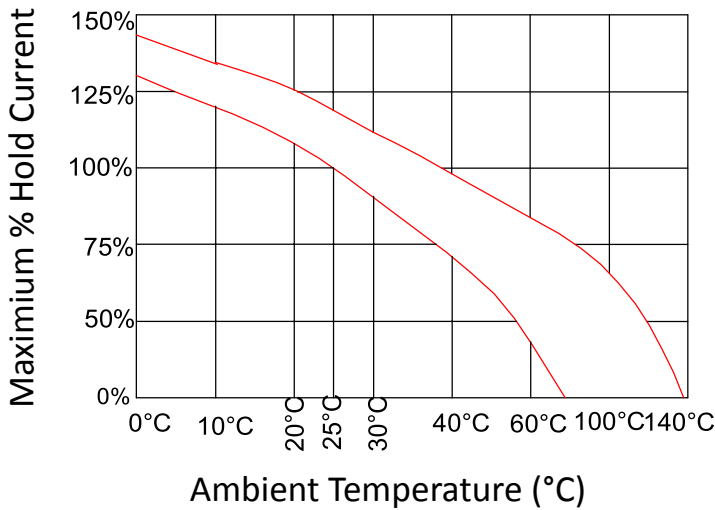

Ambient Temperature	-10°C	0°C	10°C	25°C	40°C	50°C	60°C
Division Factor	1.25	1.15	1.05	1.00	0.9	0.8	0.7

**Rev Date of issue Revision Notes**

**Designed Approved**

F	08-25-2023	Initial Drawing	RC	OF
---	------------	-----------------	----	----