

# MPM280 Pressure Sensor

## Introduction

### General MPM280 Pressure Sensor

The outline, installation dimension and sealing method of General MPM280 is strongly interchangeable, it is widely used for measuring pressure which is compatible with stainless steel and FKM.

### Assembled MPM280 Pressure Sensor

Put general MPM280 pressure sensor into the housing with standard or specialized thread; use face type seal or waterline seal; with flexible construction and strict inspecting and screening.

### Welded MPM280 Pressure Sensor

Put general MPM280 pressure sensor into the housing with standard or specialized thread; and weld sensor with housing together, no O-ring for sealing. The whole product has flexible construction, it has wider application fields than general pressure sensor, and can be used for mounting and production of different pressure instruments.



## Features

- Pressure range: 0bar ~ 0.2bar...1000bar
- Gauge, Absolute and Sealed gauge
- Constant current or Constant Voltages power supply
- Isolated construction to measure various fluid media
- $\Phi$ 19mm OEM pressure element
- 316L Stainless steel material
- Tnegtive pressure measurement is available, the lowest to around -1bar

## Application

- Industrial process control
- Level measurement
- Gas, Liquid pressure measurement
- Pressure meter
- Pressure calibrator
- Liquid pressure system and switch
- Refrigeration equipment and Air conditioner
- Aviation and Navigation inspection

## Electrical Performance

- Power supply:  $\leq 2.0\text{mA DC}$
- Electrical connection:  $\phi 0.5\text{mm}$  Kovar pin or 100mm silicon rubber flexible wires
- Common mode voltage output: 50% of input (typ.)
- Input impedance:  $3\text{k}\Omega\sim 8\text{k}\Omega$
- Output impedance:  $3.5\text{k}\Omega\sim 6\text{k}\Omega$
- Response (10%~90%):  $< 1\text{ms}$
- Insulation resistor:  $100\text{M}\Omega@100\text{V DC}$
- Overpressure: 2 times FS or 1100bar(min. value is valid)

## Construction Performance

- Diaphragm: Stainless steel 316L
- Housing: Stainless steel 316L
- Pin: Kovar
- O-ring: FKM
- Net weight:  $\sim 23\text{g}$ (general type)  
 $\sim 125\text{g}$ (assembled type)

## Environment Condition

- Shock: No change at 10gRMS,(20~2000)Hz
- Impact: 100g, 11ms
- Media compatibility: The gas or liquid which is compatible with construction material and FKM

## Basic Condition

- Media temperature: (25±1)°C
- Environment temperature: (25±1)°C
- Shock: 0.1g (1m/s<sup>2</sup>) Max.
- Humidity: (50%±10%)RH
- Local air pressure: (0.86~1.06)bar
- Power supply: (1.5±0.0015)mA DC

## Specification

Item*	Min.	Typ.	Max.	Units
Linearity		±0.15	±0.25	%FS,BFSL
Repeatability		±0.05	±0.075	%FS
Hysteresis		±0.05	±0.075	%FS
Zero output		±1.0	±2.0	mV DC
Output/Span**	70			mV DC
Zero thermal error		±0.75	±1.0	%FS, @25°C
FS thermal error		±0.75	±1.0	%FS, @25°C
Compensated temp. range		0~50		°C
Working temp. range		-40~125		°C
Storage temp. range		-40~125		°C
Long-term stability		±0.2	±0.3	%FS/Year

\* Testing at basic condition,G: Gauge; A: Absolute; S: Sealed gauge

\*\* Output/Span=full scale output - zero point

0.2bar G, FS output ≥45mV

0.35bar G, FS output ≥60mV

0.7bar A, 1.0bar A, 0.7bar GY, 1.0bar GY, FS output ≥45mV

2.0bar A, 3.5bar A, 2.0bar GY, 3.5bar GY, FS output ≥60mV

## Outline Construction (Unit: mm)

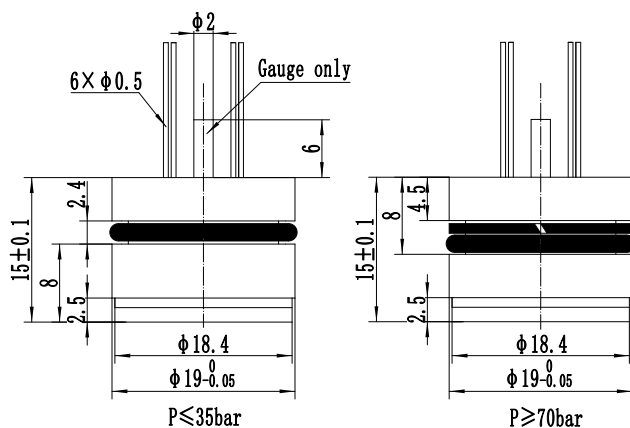

## Electrical Connection

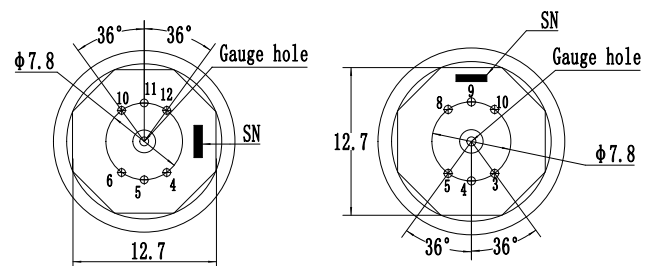

The suggested mounting dimension is  $\Phi 19_{+0.02}^{+0.05}$  mm

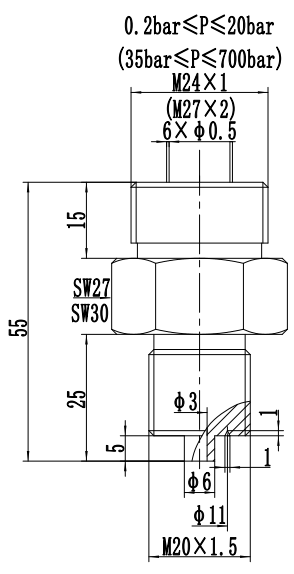

Waterline seal assembly  
H1C5/H2C5

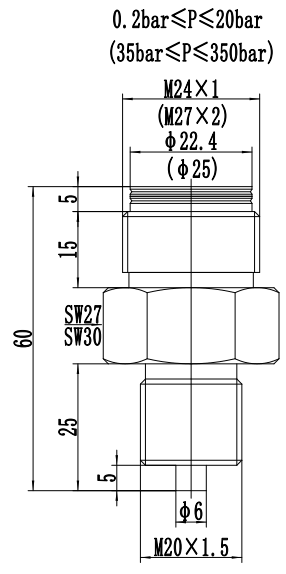

Waterline seal welded  
H3C5/H4C5

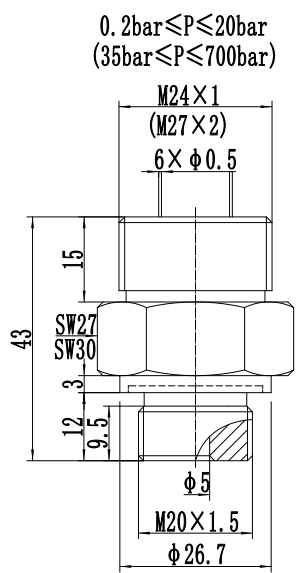

Face seal assembly  
H1C1/H2C1

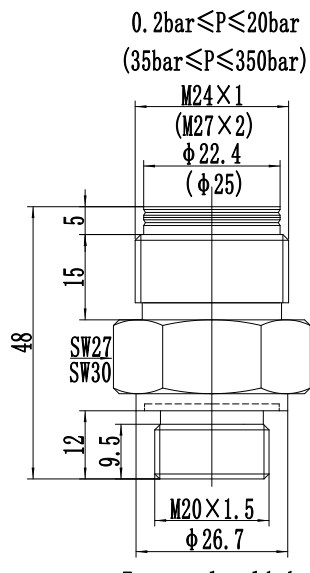

Face seal welded  
H3C1/H4C1

Pin	Definition	Wire color
4	+OUT	Red
5	+IN	Black
6	-IN	Yellow or White
10	-OUT	Blue
Other pins are useless		

Pin	Definition	Wire color
4	+OUT	Red
5	-IN	Yellow or White
8	+IN	Black
9	-OUT	Blue
Other pins are useless		

Pin	Definition	Wire color
4	-OUT	Blue
5	-IN	Yellow or White
8	+IN	Black
9	+OUT	Red
Other pins are useless		

**Notes**

The actual electrical connection method, please check the parameter label enclosed with products.

## Order Guide

MPM280		OEM Pressure Sensor					
code	range	Ref.	Range code	range	Ref.		
0B	0bar~0.2bar	G	12	0bar~20bar	G.A		
0A	0bar~0.35bar	G.A	13	0bar~35bar	G.A.S		
02	0bar~0.70bar	G.A	14	0bar~70bar	S.A		
03	0bar~1bar	G.A	15	0bar~100bar	S.A		
07	0bar~2bar	G.A	17	0bar~200bar	S.A		
08	0bar~3.5bar	G.A	18	0bar~350bar	S.A		
09	0bar~7bar	G.A	19	0bar~700bar	S.A		
10	0bar~10bar	G.A	20	0bar~1000bar	S.A		
	Code	Pressure type					
	G	Gauge					
	A	Absolute					
	S	Sealed gauge					
	Code*						
	0 or null	O-ring					
	H1	M24×1 male(assembled, P≤20bar)		C1~C31 are available for pressure connections for both assembled and welded type			
	H2	M27×2 male (assembled, P≤700bar)					
	H3	M24×1 male(welded, P≤20bar)					
	H4	M27×2 male (welded, P≤350bar)					
	C1	M20×1.5 maleface type seal		Pressure connection options for assembled or welded type			
	C2	G1/4 male					
	C3	G1/2 male					
	C4	G1/4 female					
	C5	M20×1.5male waterline seal					
	C6	1/4NPT male					
	C8	1/4NPT female					
	C10	1/2NPT male					
	C11	1/2NPTfemale					
	C15	R1/4 male					
	C31	R1/2 male					
	Code	Compensation					
	L	Laser trimming					
	M	Outer compensated resistor (providing resistor value)					
	Code	Electrical connection					
	1	Kovar pin(default)					
	2**	100mm silicon rubber flexible wires					
	Code	Special measurement					
	Y	Gauge sensor to measure vacuum(-1bar ~ 0bar)					
MPM280	09	G	0	L	1	Y	The whole spec
<p>*For assembled and welded type, please choose the top connection and pressure connection at the same time, eg. H1C2. For other customized options not shown in the order guide, please contact us.</p> <p>**For the sensor with "flexible silicone wire", the electric connection on the parameter label shall be default code "1", wire length shall be made clear on the contract.</p>							

## Notes

1. The default unit of the company's products is kPa, 1kPa=0.01bar.
2. We suggest you to use Floating construction when you install the sensor to prevent affecting sensor stability.
3. It can be used in over-range or down-range, generally within  $\pm 30\%$ .
4. The materials and processes used to manufacture negative pressure products are quite different from those of positive pressure products, and general gauge pressure products cannot be used to replace negative pressure products.
5. Confirm the maximum overload of the system, the maximum overload of the system is less than the maximum overload of the product, otherwise it will affect the performance and service life of the product, and even cause the product to be damaged.
6. For the temperature compensation of conventional products under the condition of constant current source, constant current power supply should be selected to ensure temperature performance.
7. Please pay attention to protect sensor isolated diaphragm and ceramic compensated board, to avoid damaging sensor or affecting the performance.
8. Temperature resistant range of standard FKM O-ring of sensor is  $-20\text{ }^{\circ}\text{C} \sim 250\text{ }^{\circ}\text{C}$ . When working temperature is lower than  $-20\text{ }^{\circ}\text{C}$ , or sensor is applied in critical environment, please contact us.