

SPECIFICATION

For

SWITCHING POWER SUPPLY

M/N: MPI-806H

Revision History

Version	Revise Date	Change Items
Rev. 01	May. 30. 2007	Adding index page and OVP description.
Rev. 02	Jun. 29. 2007	Reducing minimum load of +5V output from 1A to 0.5A.
Rev. 03	Jan. 2. 2008	Extending min. operating temperature from 0°C to -10°C.
Rev. 04	Jun. 24. 2008	OVP description update.
Rev. 05	Sep. 28. 2010	Updating the safety approval status.
Rev. 06	Mar. 28. 2011	Updating the safety approval status; revised the hi-pot withstand.
Rev. 07	Aug. 16. 2011	Revised the description of ripple noise.
Rev. 08	Nov. 24. 2014	1. Correct writing at load regulation definition in 3.0. 2. Operating temperature from -20~+70 to -40~+70.
Rev. 10	Feb. 9. 2018	1. Changed form. 2. Added EN 55032.
Rev. 11	Jan. 16. 2019	Added output current to output field.



FEATURES

- ✓ 80W with 8.6CFM forced air-cooling, 60W convection cooling.
- ✓ Compact size with ATX output.
- ✓ PG/PF Signal.
- ✓ +5V Stand-by & Remote On/Off.
- ✓ MTBF>130,000 hr. MIL-217F.



Models & Ratings

Model Number	Wattage (Rated / Max)	Output Voltage		Min. Current	Rated Current	Max. Current (Note 1)
MPI-806H	60 W / 80 W	V1	+5 V	0.5 A	5.0 A	8.0 A
		V2	+12 V	0 A	1.5 A	3.0 A
		V3	-12 V	0 A	0.5 A	-
		V4	+3.3 V	0 A	4.0 A	6.0 A
		V5	+5Vsb	0 A	0.75 A	-

Total Output Power: 80W at 50°C environment temperature (Note 2)

Note:

1. The maximum total combined output power on the +3.3V and +5V rails is 40W.
2. Total maximum load cannot exceed 80W with 8.6 CFM forced air-cooling and 60W convection cooling.

Summary

Characteristic	Minimum	Typical	Maximum	Units	Notes & Conditions
Input Range	90	115 / 230	264	VAC	Continuous input range.
Input Frequency	47		63	Hz	AC input.
Efficiency		70		%	Rated load, 115VAC. Varies with distribution of loads among output.
Operation Temperature	-10		+70	°C	Derate linearly above 50°C by 2.5% per °C to a maximum temperature of 70°C at 50% load.
Weight		387.4		g	
Dimensions	128.0 (L) x 81.0 (W) x 40.0 (H) mm, Tolerance +/- 0.4mm.				
EMC	EN 55022 / EN 55032 / CISPR 22 & FCC Part 15 IEC 61000-4-2, IEC 61000-4-3, IEC 61000-4-4, IEC 61000-4-5, IEC 61000-4-6, IEC 61000-4-8, IEC 61000-4-11				
Safety Approvals	IEC 60950-1: 2001, 1 st , EN 60950-1: 2006+A11, UL 60950-1, 2nd edition, 2007-03-27, CSA C22.2 No. 60905-1-07, 2nd Edition, 2007-03				

Input

Characteristic	Minimum	Typical	Maximum	Units	Notes & Conditions
Input Voltage	90	115 / 230	264	VAC	Continuous input range.
Input Frequency	47		63	Hz	AC input.
Input Current			2 / 1	A	Nominal AC Input Voltage (115VAC/230VAC), rated load.
Inrush Current			30 / 60	A	Nominal AC Input Voltage (115VAC/230VAC), one cycle at 25°C.
Input Protection	One non-user serviceable internally located AC input line fuse. Fuse : 5A / 250VAC * 1pcs				

Output

Characteristic	Minimum	Typical	Maximum	Units	Notes & Conditions
Output Voltage		+5 V		DC	
		+12 V			
		-12 V			
		+3.3 V			
		+5Vsb			
Output Current		5.0	8.0	A	
		1.5	3.0		
		0.5			
		4.0	6.0		
		0.75			
Initial Set Accuracy	5.08		5.13	VDC	The +5V output is set between 5.08V to 5.13V by variable resistor and all output at 60% rated load and the other outputs are checked to be within the accuracy range.
	11.4		12.6		
	-11.4		-12.6		
	3.10		3.50		
	4.80		5.20		
Minimum Load		0.5		A	At Output Voltage +5V At Output Voltage +12 V, -12 V, +3.3 V, +5Vsb
		0			
Start Up Delay	0.3		4	Sec	Time required for initial output voltage stabilization.
Hold Up Time	20			mS	Nominal AC Input Voltage (230VAC), rated load.
Line Regulation		±1.0 ^(V1) ±1.0 ^(V2) ±1.0 ^(V3) ±1.0 ^(V4) ±1.0 ^(V5)		%	Less than ±1% at rated load with ±10% changing in input voltage.
Load Regulation		±2.0 ^(V1) ±4.0 ^(V2) ±5.0 ^(V3) ±4.0 ^(V4) ±4.0 ^(V5)		%	Measured from 60% to 100% rated load and from 60% to 20% rated load (60% ±40% rated load) for each output, and keep other outputs at 60% rated load.
Ripple & Noise		50 ^(V1) 120 ^(V2) 120 ^(V3) 50 ^(V4) 120 ^(V5)		mV	Measured at rated load by a 20MHz bandwidth limited oscilloscope and the each output is connected with a 10µF Electrolytic Capacitor and a 0.1µF Ceramic Capacitor.
Over Load Protection	Fully protected against output overload and short circuit. Automatic recovery upon of overload condition.				
Over Voltage Protection	For some reason the PSU fails to control itself, the build-in over voltage protection circuit will shut down the outputs and go into hiccup mode to prevent damaging external circuits. The trigger point is about 6.5-8.5V at +5V and the PSU will auto-recovery once the failure condition been removed.				

General

Characteristic	Minimum	Typical	Maximum	Units	Notes & Conditions
Efficiency		70		%	Rated load, 115VAC. Varies with distribution of loads among output.
Isolation IP to OP	3000			VAC	
Switching Frequency		65		KHZ	
Power Good Signal	When power is turned on, the power good signal will go high 100ms to 500ms after all output DC voltages are within regulation limits.				
Power Fail Signal	The power fail signal will go low at least 1 mS before any of the output voltages fall below the regulation limits.				
Power On / Off	The power supply will be turned on when the power On/Off pin is connected to secondary GND.				

Environmental

Characteristic	Minimum	Typical	Maximum	Units	Notes & Conditions
Operating Temperature	-10		+70	°C	Derate linearly above 50°C by 2.5% per °C to a maximum temperature of 70°C at 50% load.
Storage Temperature	-40		+70	°C	
Relative Humidity	5		95	%RH	Non-condensing.
Cooling		8.6		CFM	Forced-cooled @ 80W
Operating / Non- Operating Altitude		10000 / 40000		Feet	

Derating curve

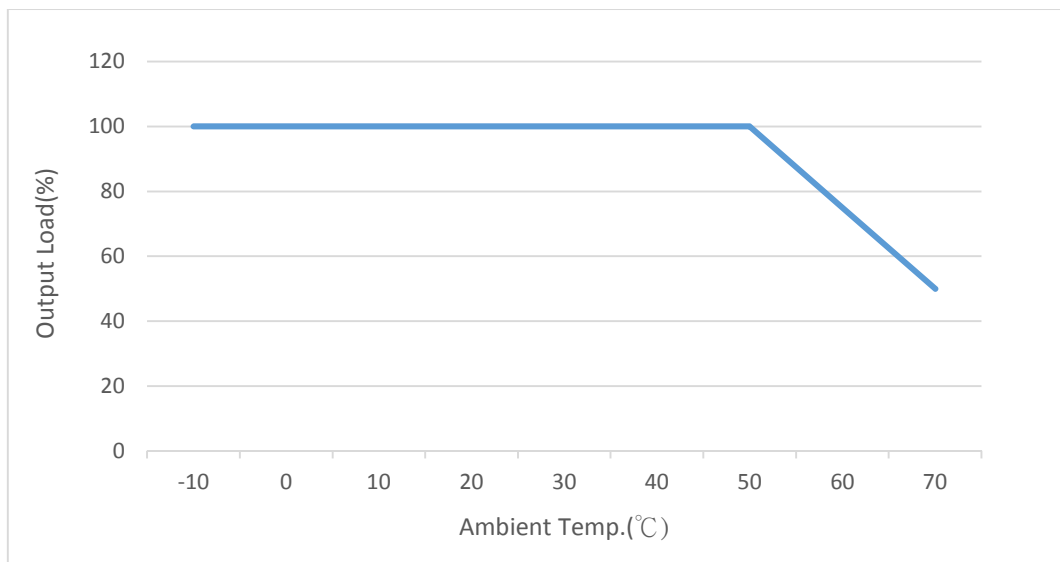

EMC: Emissions

Phenomenon	Standard	Class	Notes & Conditions
Conducted	EN 55022 / EN 55032 CISPR 22 & FCC Part 15	B	
Radiated	EN 55022 / EN 55032 CISPR 22 & FCC Part 15	B	

EMC: Immunity

Phenomenon	Standard	Criteria	Notes & Conditions
ESD	IEC 61000-4-2	A	8KV air discharge, 6KV contact discharge
Radiated	IEC 61000-4-3	A	3V/m
EFT	IEC 61000-4-4	A	2KV Line & PE
Surges	IEC 61000-4-5	A	2KV
Conducted	IEC 61000-4-6	A	10V
Power Magnetic	IEC 61000-4-8	A	10A/m
Dips and Interruptions	IEC 61000-4-11	A A B	DIP: >95%, 0.5 cycle DIP: >30%, 25 cycles INT: >95%, 250 cycles

Safety Approvals

Safety Agency	Safety Standard	Notes & Conditions
TUV	EN 60950-1: 2006+A11	Approved.
CB	IEC 60950-1: 2001, 1 st	Approved.
UL/cUL	UL 60950-1, 2nd edition, 2007-03-27 CSA C22.2 No. 60905-1-07, 2nd Edition, 2007-03	Approved.

Mechanical Details

SIZE : 128.0 (L) x 81.0 (W) x 40.0 (H) mm, Tolerance +/- 0.4mm.

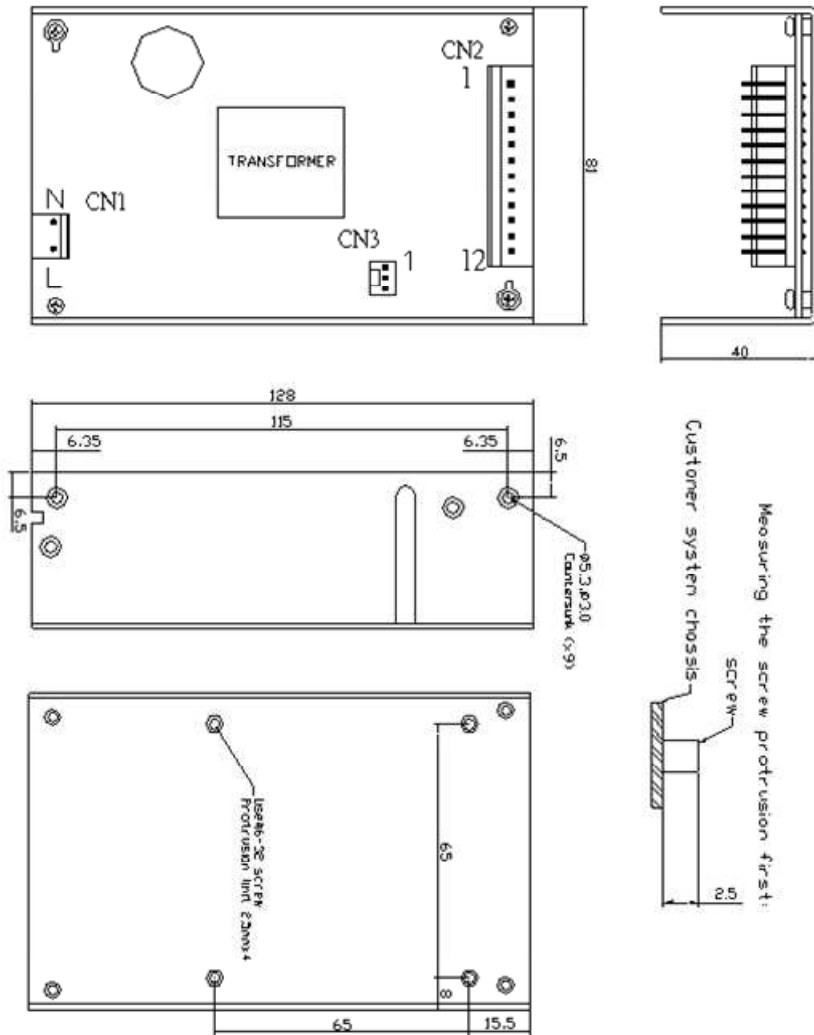

Parameter	Conditions/Description					
Dimension	128 x 81 x 40 mm, Tolerance +/- 0.4mm.					
Connector	CN1 --- AC input: Molex 5273-03A withdraw 1 pin or equivalent.					
	CN2 --- DC output: Molex 5273-12A or equivalent.					
	CN3 --- DC output: Molex 5045-03A.					
Pin Assignment	CN1	Pin	1. N	2. L		
	CN2	Pin	1. +3.3V	4. GND	7. +5V	10. PG/PF
			2. +3.3V	5. GND	8. +5V	11. +12V
CN3	Pin	3. GND	6. GND	9. +5V	12. -12V	
		1. +5Vsb	2. GND	3. PS on/off		

Options

Parameter	Conditions/Description
Cable (No. 866-806H)	ATX connector, HDD connector x 2, FDD connector x 1

Thermal Considerations

In order to ensure safe operation of the PSU in the end-use equipment, the temperature of the components listed in the table below must not be exceeded.

Temperature should be monitored using J type thermocouples placed on the hottest part of the component (out of any direct air flow). See Mechanical Details for component locations.

Temperature Measurements at max. amb.	
Component	Max Temperature
T1	110°C
Q1	120°C
D5	120°C
C2	105°C
C23	105°C