

SPECIFICATION

For

SWITCHING POWER SUPPLY

M/N: MPE-S153 (12V / 12.5A)

Peak Power Enhanced Thin Model

Revision History

Version	Revise Date	Change Items
Rev. 01	Sep. 11. 2021	Established.

MPE-S153

150W AC / DC



FEATURES

- ✓ 200W Peak power for 3.8s.
- ✓ 150W fan cooling, 100W with convection-cooled.
- ✓ size 2 x 4 inch, height 1 inch.
- ✓ Wide operating temperature -20~80°C.
- ✓ High efficiency up to 90%
- ✓ No-load power consumption < 0.1W.
- ✓ Class II, also class I with optional functional ground connected.
- ✓ EN 62368-1(LVD) approved, designed to meet IEC 62368-1, IEC 60335-1, IEC 60601-1.
- ✓ Meets EMI CISPR / FCC class B.
- ✓ 5,000m operation altitude.



Models & Ratings

Model Number	Wattage (Rated / Max)	Output Voltage	Min. Current	Rated Current	Max. Current	Peak Current (for 3.8s)
MPE-S153	100 W / 150 W	+12 V	0 A	8.33 A (Note1)	12.5 A (Note1)	16.67 A (Note1)

Output Power: 100W with convection cooling, 150W with 10.8 CFM at 50°C.

Note:

1. See the following performance curves for the detail.
2. Model no. coding:

MPE-S153-X

①

①	X=	Connector Type
	blank	JST Type Connector or equivalent

Input

Characteristic	Minimum	Typical	Maximum	Units	Notes & Conditions
Input Voltage	85	115 / 230	264	VAC	Continuous input range.
Input Frequency	47	60 / 50	63	Hz	AC input.
Input Current			3.0 / 1.8	A	Nominal AC Input Voltage (115VAC / 230VAC), Max load.
Inrush Current			30 / 60	A	Nominal AC Input Voltage (115VAC/230VAC), one cycle at 25°C cold start.
No-load power consumption			0.1	W	Nominal AC Input Voltage (230VAC/50Hz).
Switching Frequency		65		KHz	
Input Protection	One non-user serviceable internally located AC input line fuse. Fuse : 5A / 250VAC * 2pcs				

Output

Characteristic	Minimum	Typical	Maximum	Units	Notes & Conditions
Output Voltage		+12 V		Vdc	
Output Current		8.33	12.5	A	16.67A for peak current (3.8s)
Efficiency		90		%	At input 230VAC, rated load, above 1hr. warm up.
Initial Set Accuracy		±1.0		%	Initial setting accuracy is adjusted at input 115VAC and output at 60% rated load.
Minimum Load		0		A	
Start Up Delay		0.5		Sec	Time required for initial output voltage stabilization.
Hold Up Time		9 / 28		mS	Nominal AC Input Voltage (115VAC/230VAC), rated load.
Line Regulation		±0.5		%	Less than ±1% at rated load with ±10% changing in input voltage 115VAC.
Load Regulation		±1.0		%	Measured from 60% to 100% rated load and from 60% to 20% rated load (60% ±40% rated load).
Ripple & Noise			120 / 90	mV	Measured at rated load and Nominal AC Input Voltage (115VAC/230VAC) by a 20MHz bandwidth limited oscilloscope and the each output is connected with a 10µF Electrolytic Capacitor and a 0.1µF Ceramic Capacitor.
Leakage Current			100 / 300	uA	Functional Condition / Open Circuit Condition.
Overvoltage Protection	For some reason the power supply fails to control itself, the build-in over voltage protection circuit will Latch-off the outputs to prevent damaging external circuits, the trigger point is around 110%~130% of output voltage.				
Short Circuit Protection	Fully protected against output overload and short circuit. Automatic recovery upon of overload condition.				

Environmental

Characteristic	Minimum	Typical	Maximum	Units	Notes & Conditions
Operating Temperature	-20		+80	°C	See the following performance curves for the detail.
Storage Temperature	-40		+85	°C	
Relative Humidity	5		95	%RH	Non-condensing.
Cooling	10.8			CFM	Forced-cooled when 100W~150W
Operating Altitude		5000		m	

Derating curve

1. Output Power (W) versus Ambient Temp.(°C) Curve

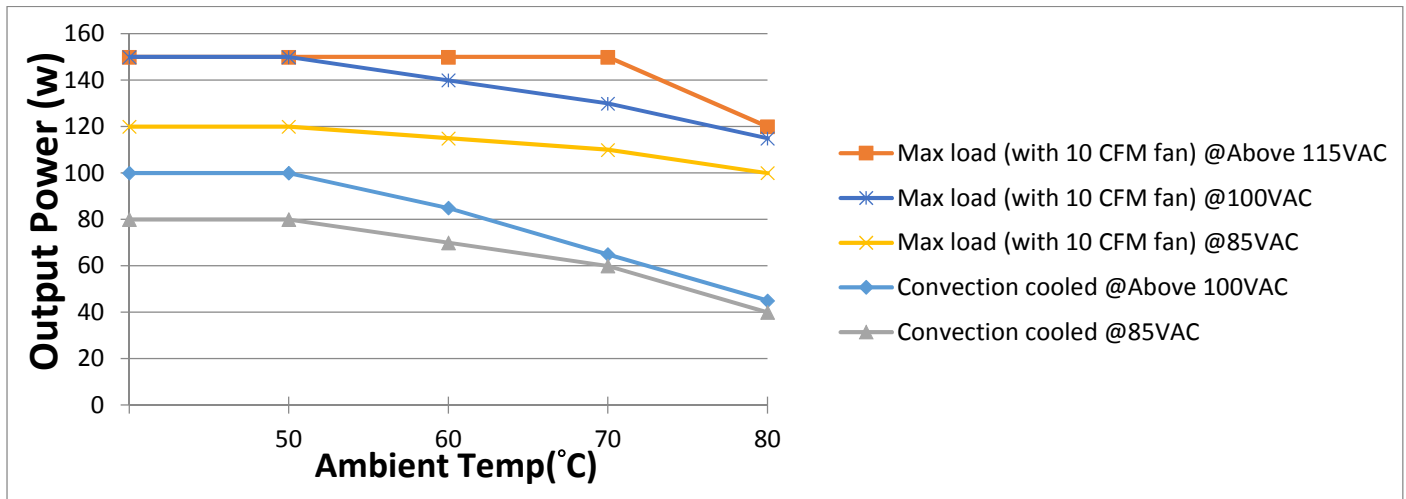

2. Output Power (W) versus Input Voltage(VAC) Curve

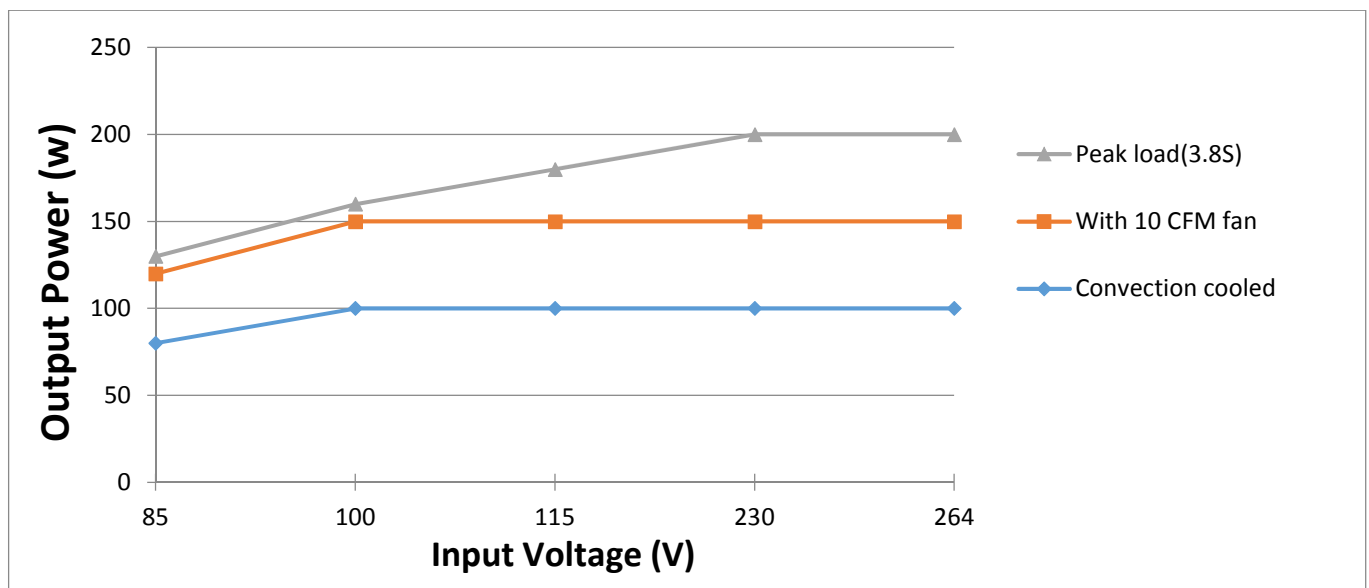

Note: If the operating temp exceeds 50°C, please refer to graph 1 for deration curve and according output proportion.

3. Low Temp cold Start (W) versus Input Voltage(VAC) Curve

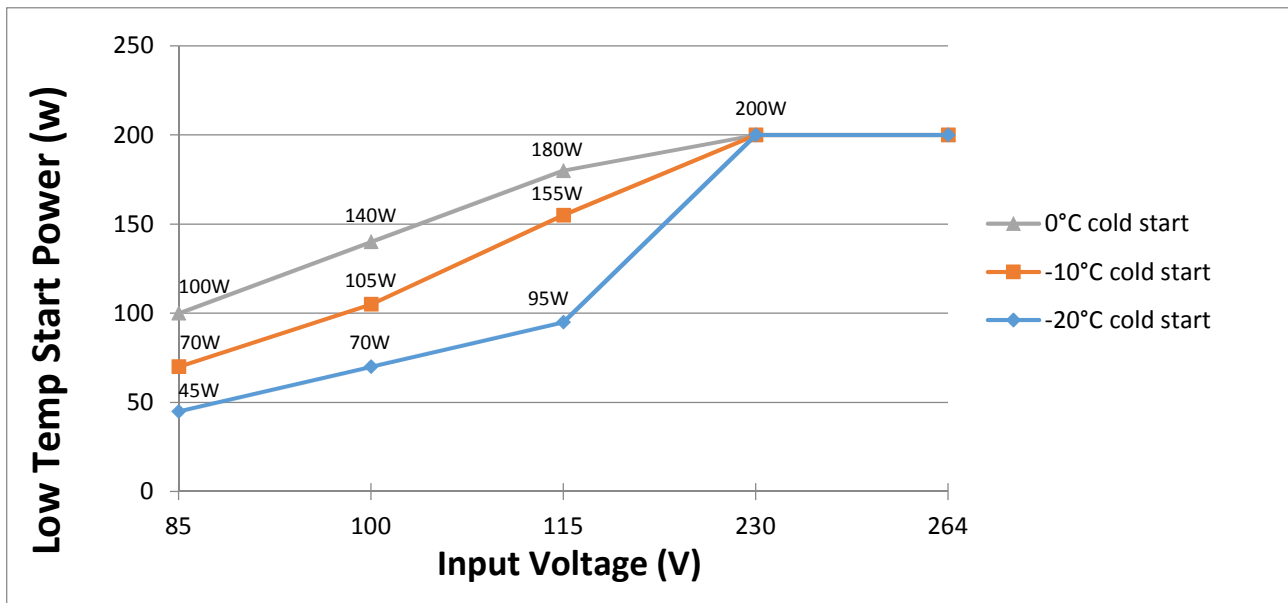

EMC: Emissions

Phenomenon	Standard	Class	Notes & Conditions
Conducted	EN 55022 / EN 55032 CISPR 22 & FCC Part 15	B	Mounting holes should be connected to Ground to conform the EMI limit (Class II refers to Note 1).
Radiated	EN 55022 / EN 55032 CISPR 22 & FCC Part 15	B	
Harmonic Current	EN 61000-3-2	A	AC Input : 230VAC, Load : 150W
Voltage Flicker	EN 61000-3-3	PASS	

Note:

- For Class II radiation, recommend to add a 4 turns core at input. (part#: EROCORE A8I280200160)

EMC: Immunity

Phenomenon	Standard	Criteria	Notes & Conditions
ESD	IEC 61000-4-2	A	±15KV air discharge, ±8KV contact discharge
Radiated	IEC 61000-4-3	A	10V/m
EFT	IEC 61000-4-4	A	±2KV Line & PE
Surges	IEC 61000-4-5	A	L-N:±1KV, L/N-PE:±2KV
Conducted	IEC 61000-4-6	A	10V
Power Magnetic	IEC 61000-4-8	A	30A/m
Dips and Interruptions	IEC 61000-4-11	A / B A / B A / B B	DIP: >95%, 0.5 cycle DIP: 30%, 25 cycles ^(Note 2) DIP: 60%, 5 cycles ^(Note 2) INT: >95%, 250 cycles

Note:

- As a build-in type power supply, the power supply needs to be installed in a suitable enclosure to pass the EMI/EMC tests. The final assembly has to comply with the valid EMI/EMC and safety.
- The test result of input 240Vac / 100Vac is criteria A / B.
- The mounting holes should be connected to each other to conform the EMI limit.

Safety Approvals

Characteristic	Minimum	Typical	Maximum	Units	Notes & Conditions
Isolation	IP to OP	4000			VAC
	IP to GND	1800			VAC
Safety Agency	Safety Standard				Notes & Conditions
TUV	EN 62368-1, 2 nd Edition				Designed to meet. (LVD EN 62368-1 approved.)
	EN 60335-1				
	EN 60601-1				
CB	IEC 62368-1, 2 nd Edition				
	IEC 60335-1				
	IEC 60601-1				
UL/cUL	UL 62368-1, 2 nd Edition, CSA C22.2 No. 62368-1-14, 2 nd Edition				
	UL 60335-1				
	UL 60601-1				

Mechanical Details

Unit: mm

SIZE : 101.6(L) x 50.8(W) x 25.4 mm, Tolerance +/-0.5mm.

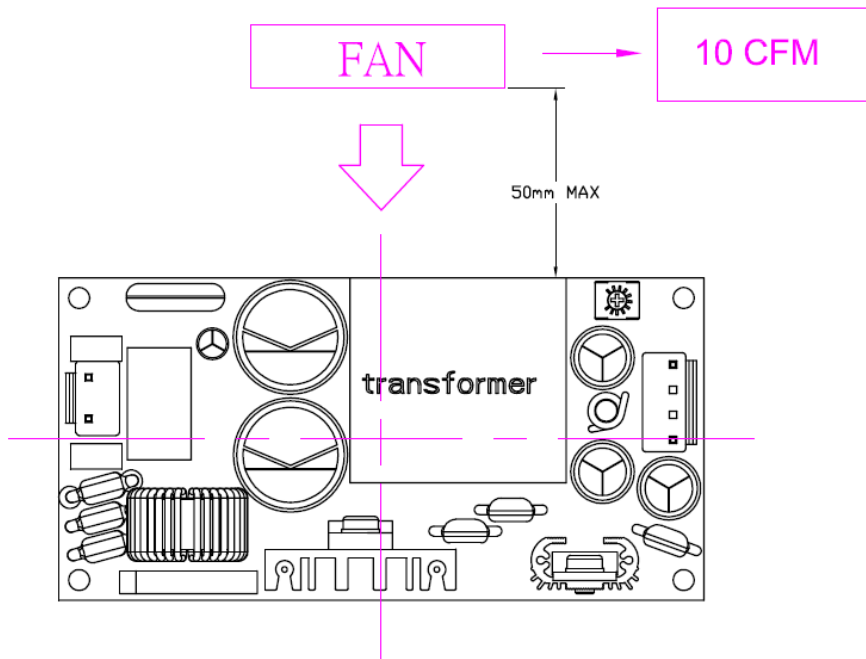
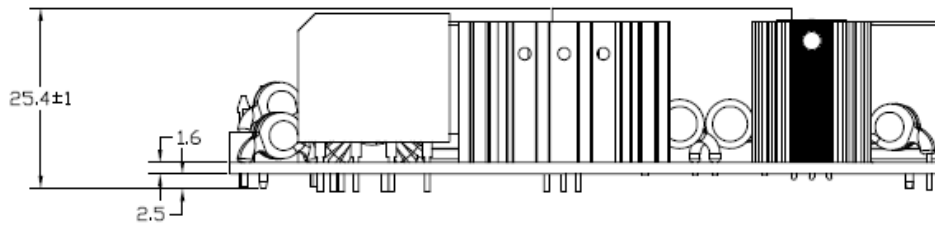
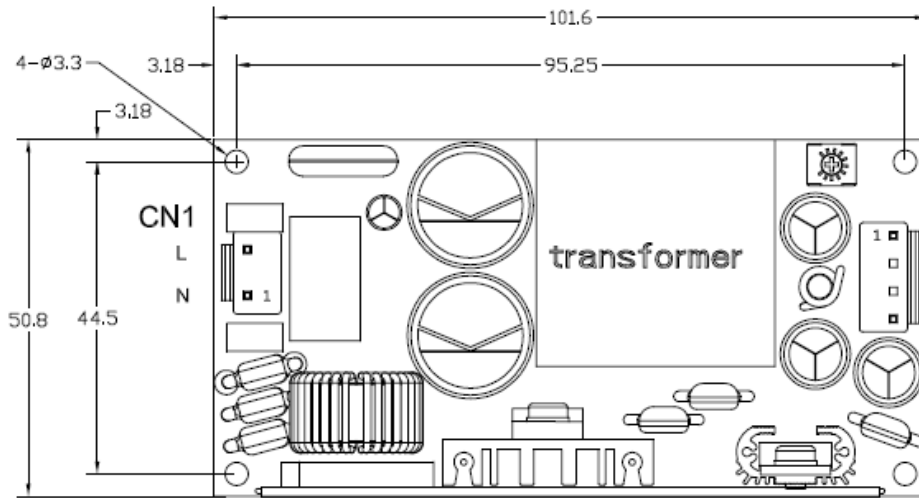

Performance

(Input voltage: 115Vac)

Switching frequency ripple rated load

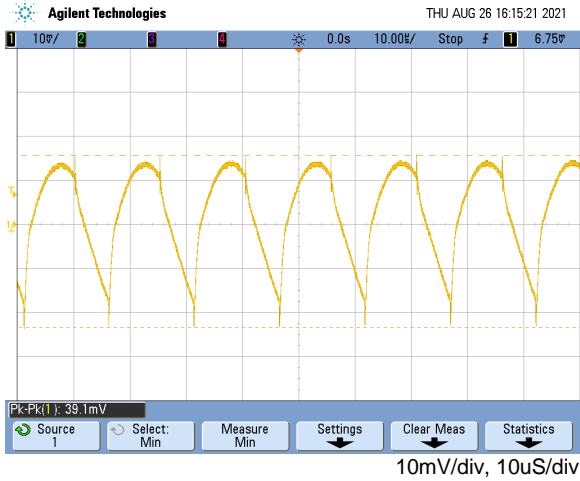

Line frequency ripple rated load

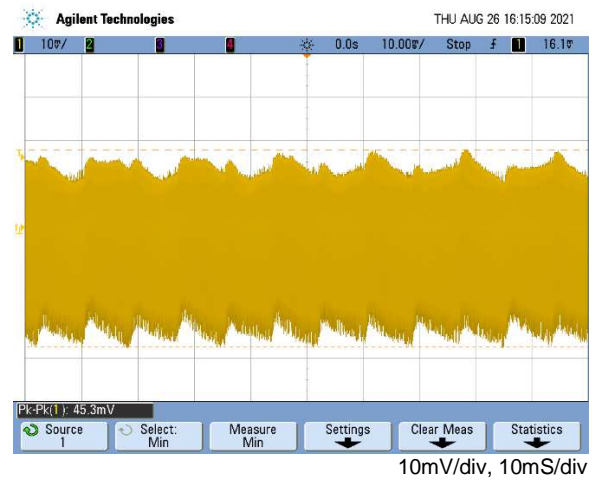

Output turn-on rated load

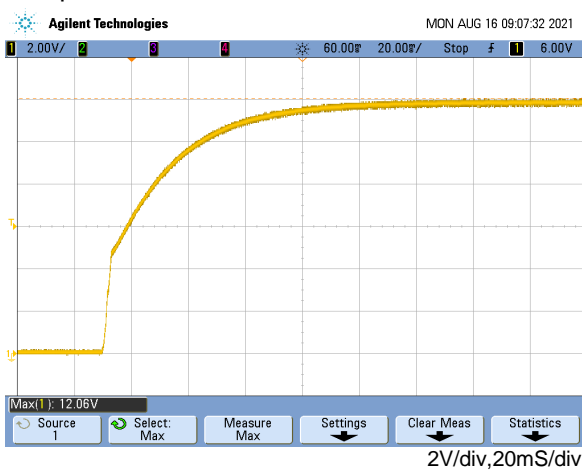

Output turn-off rated load

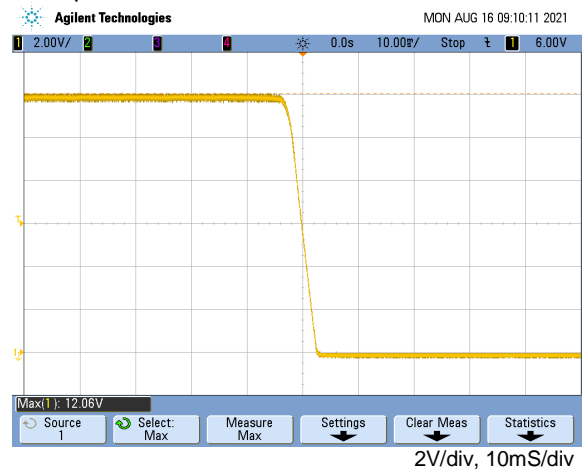

Hold-up time rated load

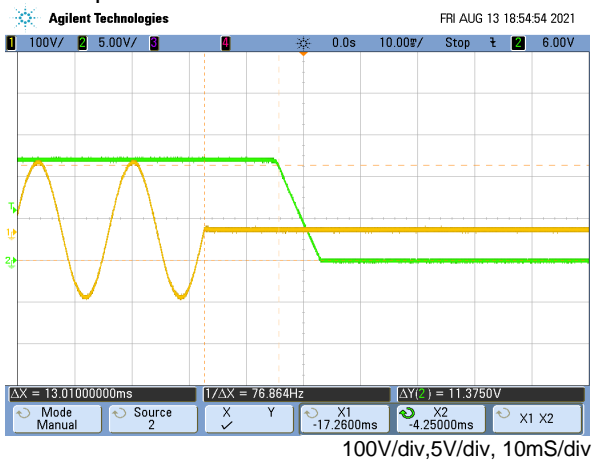

OVP 60% of rated load

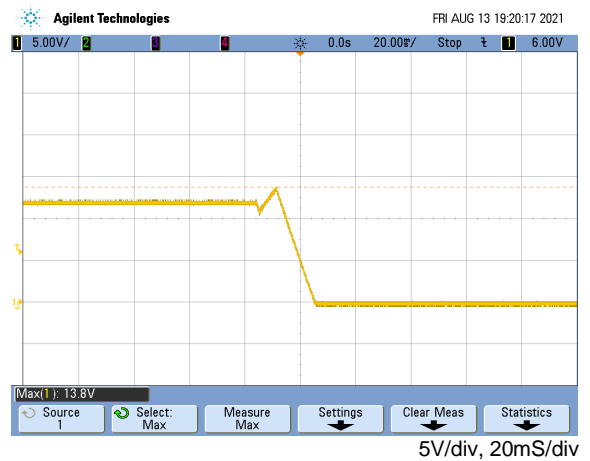

Step response

20%~100% of rated load

Agilent Technologies

THU AUG 26 16:18:50 2021

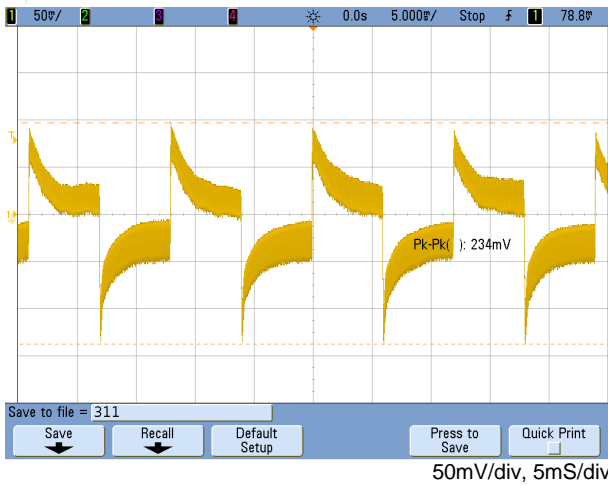

EMI: EN 55032 "B" (Conduction)

Date: 2021-08-30

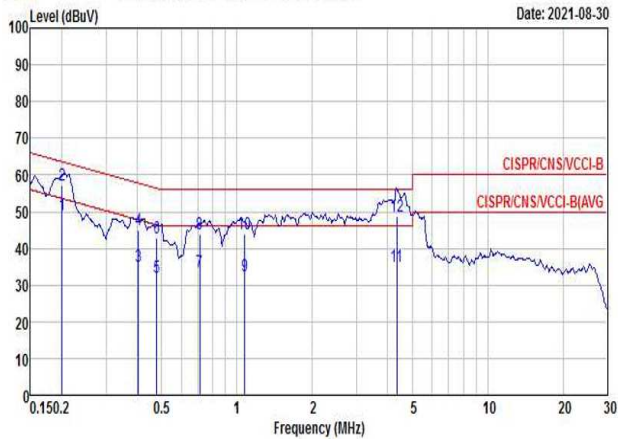

230Vac/Rated load

EMI: FCC "B" (Conduction)

Date: 2021-08-30

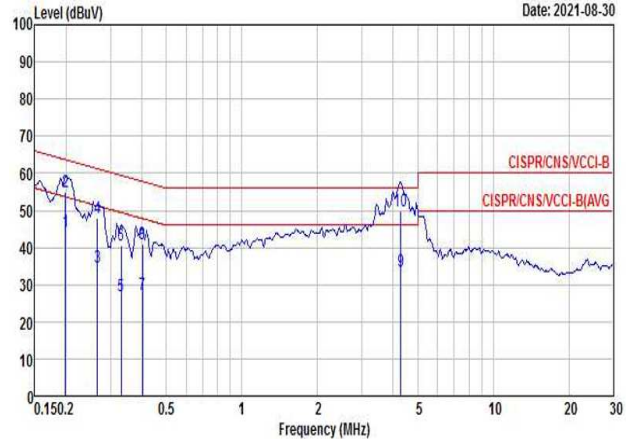

115Vac/Rated load

EMI: EN 55032 "B" (Radiation)

Date: 2021-09-16

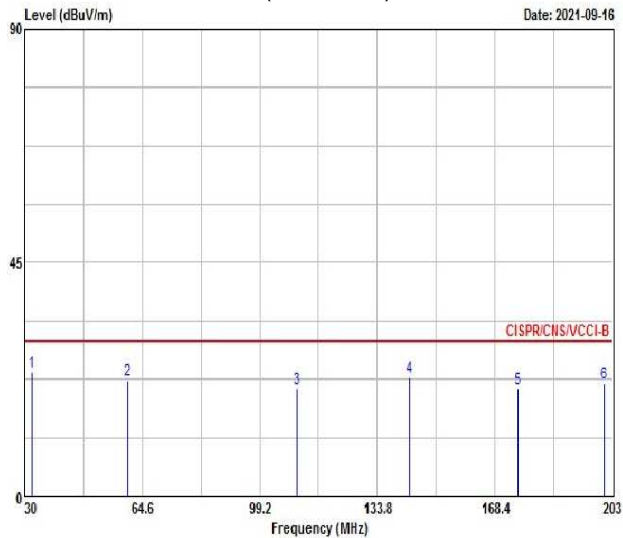

230Vac/Rated load

EMI: FCC "B" (Radiation)

Date: 2021-09-16

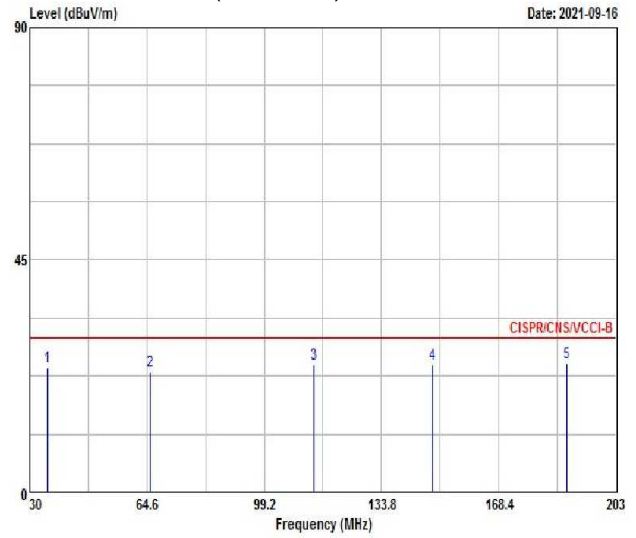

115Vac/Rated load

Thermal Considerations

In order to ensure safe operation of the PSU in the end-use equipment, the temperature of the components listed in the table below must not be exceeded.

Temperature should be monitored using J type thermocouples placed on the hottest part of the component (out of any direct air flow). See Mechanical Details for component locations.

Temperature Measurements at max. amb.	
Component	Max Temperature
T1	110°C
Q1	130°C
Q2	130°C
C1B	105°C
C11A	105°C