

## Features:

- Frequency Range: 24 – 30 GHz
- P1dB: 34 dBm
- IM3 Level: -25 dBc @ Po = 27 dBm/tone
- Gain: 23 dB
- Vdd = 6V
- Idsq = 1100 to 1800mA
- Input and Output Fully Matched to 50 Ω
- Output Power Detector

## Applications:

- Point-to-Point Radio
- VSAT
- 5G

## Description:

The MMA-243034D-M5 is a 2.5W GaAs pHEMT MMIC power amplifier in a compact 5 mm QFN surface mount package. The MMA-243034D-M5 provides 34 dBm of output power (P-1dB) and 23 dB of small-signal gain from 24GHz to 30GHz.

## Absolute Maximum Ratings: (Ta= 25 °C)\*

SYMBOL	PARAMETERS	UNITS	Min.	Max.
Vd	Drain Voltage	V		6.5
Vg	Gate Voltage	V	-2.1	0
Ig	Gate Current	mA	-17	17
Pd	Power Dissipation	W		24
Pin max	RF Input Power	dBm		20
Tch	Channel Temperature	°C		+150
Tstg	Storage Temperature	°C		-55 to +150
Tmax	Max. Assembly Temp (20 sec max)	°C		+250

\*Operation of this device above any one of these parameters may cause permanent damage.

Functional Block Diagram

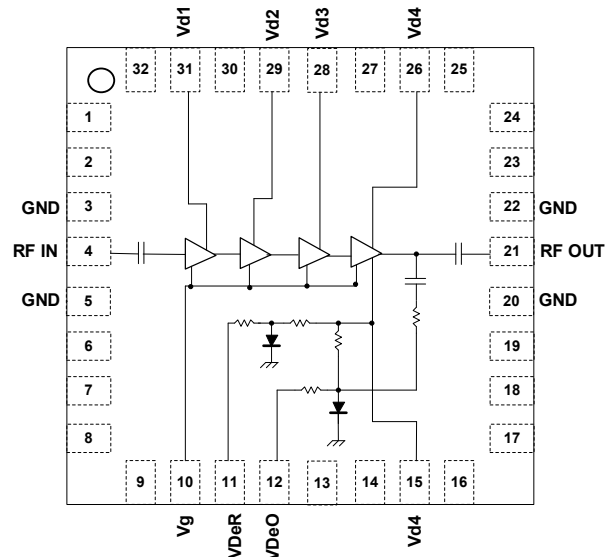



# **MMA-243033D-M5**

**24 – 30 GHz, 2.5W MMIC Power Amplifier**  
**Data Sheet**

## **Electrical Specifications:** $V_d = 6V, I_{dq} = 1600mA, T_a = 25\text{ }^\circ\text{C}, Z_o = 50\text{ ohm}$

<b>Parameter</b>	<b>Units</b>	<b>Typical Data</b>
<b>Frequency Range</b>	GHz	24-30
<b>Gain</b>	dB	23
<b>Gain Flatness</b>	+/-dB	2
<b>Input Return Loss</b>	dB	8
<b>Output Return Loss</b>	dB	10
<b>VdeR</b>	V	0.9
<b>VdeO @28GHz, @ Po = +20dBm</b>	V	0.82
<b>@ Po = +33dBm</b>	V	0.0
<b>Output P1dB</b>	dBm	34
<b>Output P3dB</b>	dBm	34.5
<b>IM3 Level (1)</b>	dBc	-25
<b>Thermal Resistance</b>	$^\circ\text{C}/\text{W}$	5.3
<b>Total Drain Current at P1dB</b>	mA	2100

(1) Output IP3 is measured with two tones at output power of 27 dBm/tone separated by 20 MHz.

**Typical RF Performance:  $V_d = 6V$ ,  $I_{dq} = 1600mA$ ,  $V_g = -0.85V$  typical,  $Z_o = 50\text{ ohm}$**

**Small Signal Gain vs. Frequency**

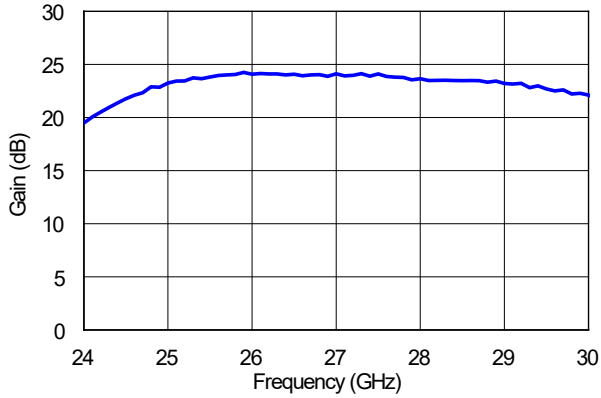

**Input Return Loss vs. Frequency**

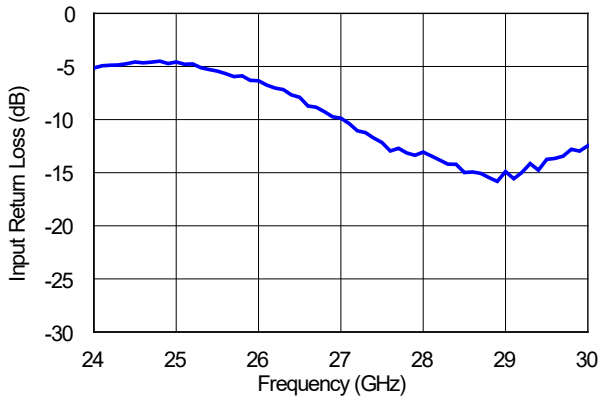

**Output Return Loss vs. Frequency**

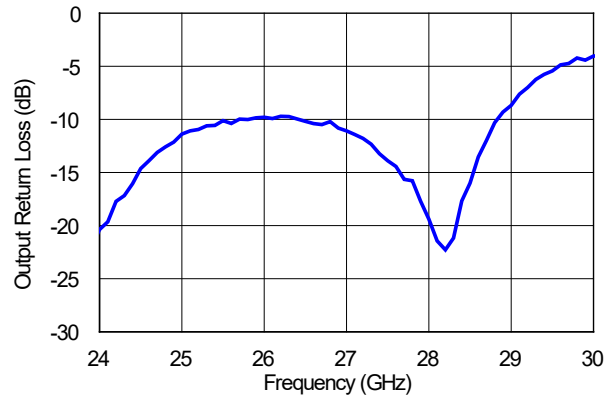

Output Power

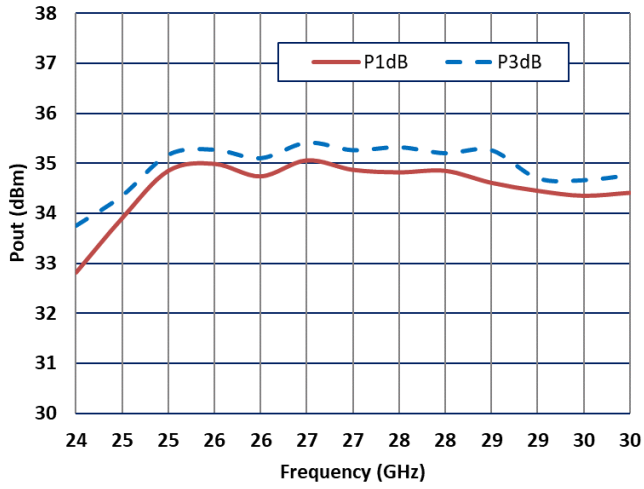

Detector Output vs. Output Power

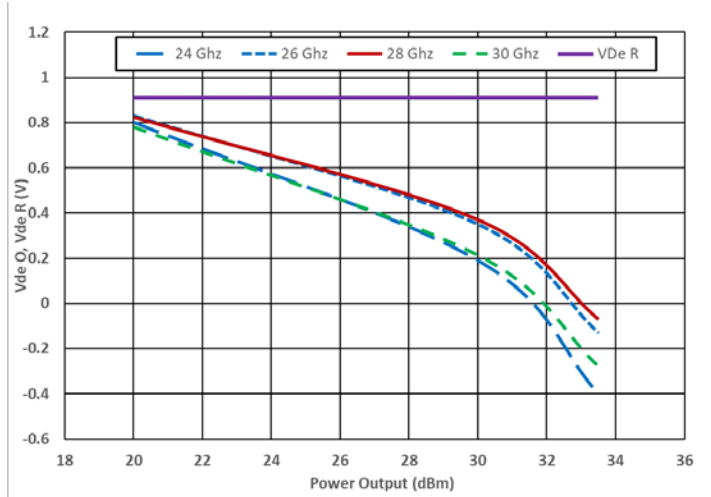

## Package Pin Designations:

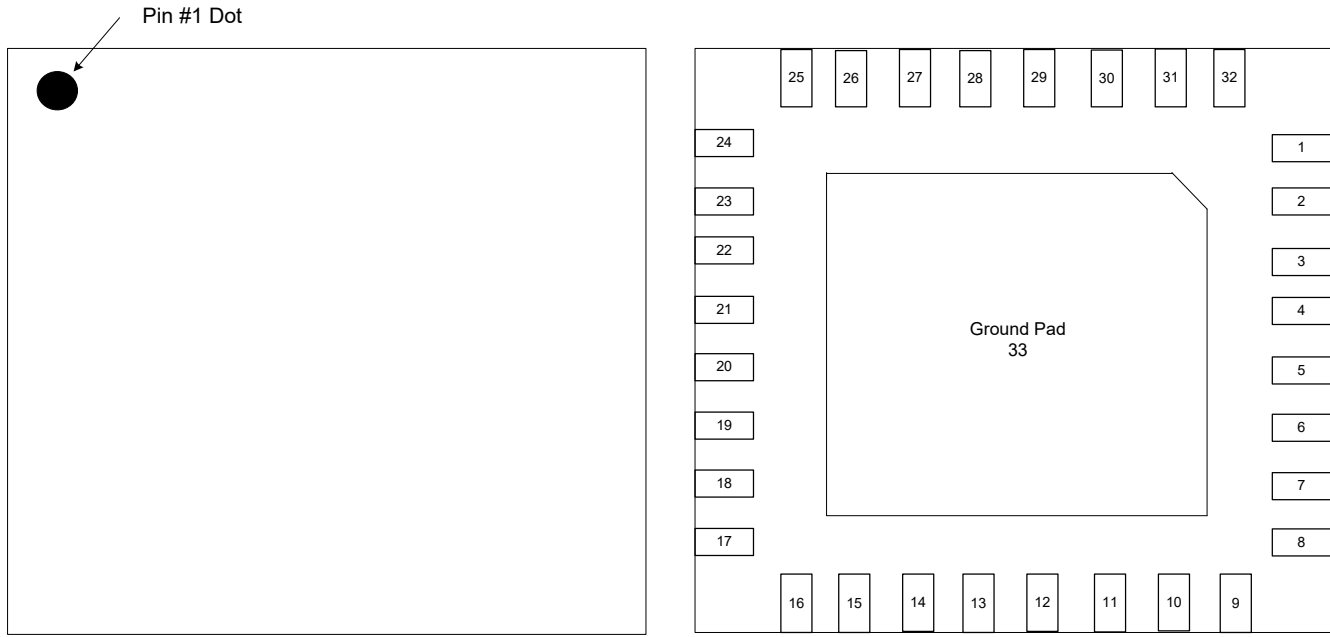

Pin	Description
4	RF Input
21	RF Output
10	Vg
31	Vd1
29	Vd2
28	Vd3
15, 26	Vd4
11	VdeR
12	VdeO
1, 3, 5, 8, 9, 16, 17, 20, 22, 24, 25, 32, 33	Ground
2, 6, 7, 11, 12, 13, 14, 18, 19, 23, 27, 30	N/C

## Mechanical Drawing

The package is a 32-Lead 5x5mm air-cavity QFN package that is compatible with industry standard surface mount PCB assembly processes.

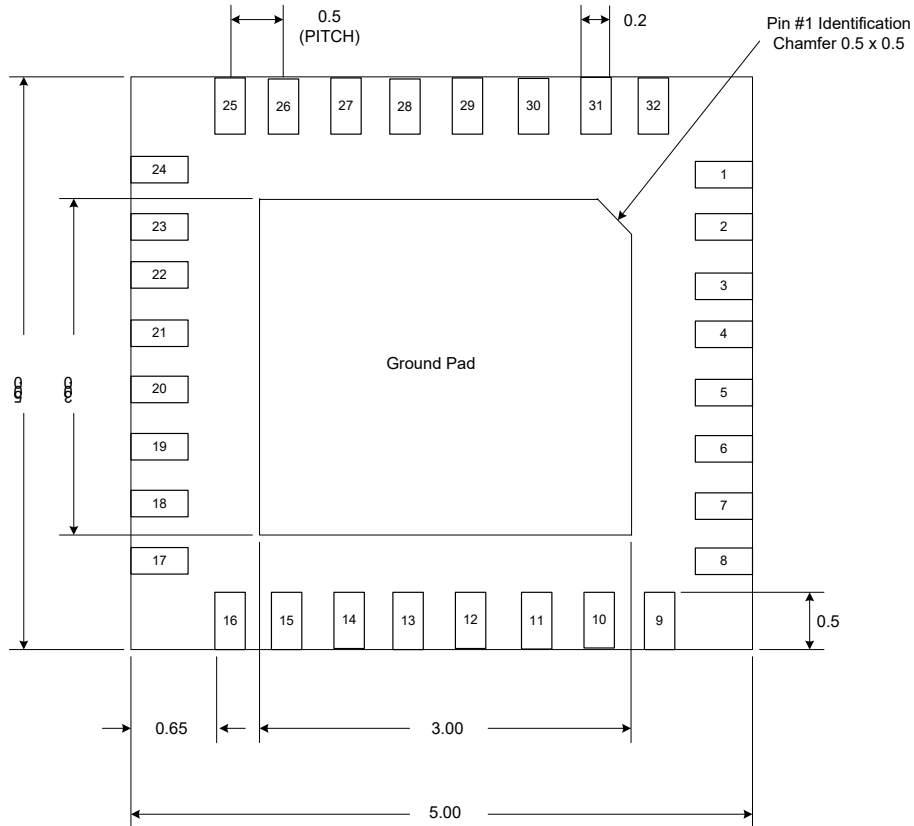

BOTTOM VIEW

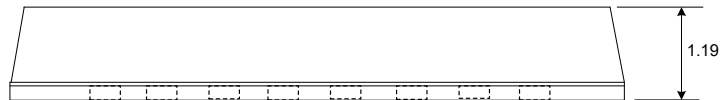

SIDE VIEW

The units are in [mm].

## Sample Application Circuit:

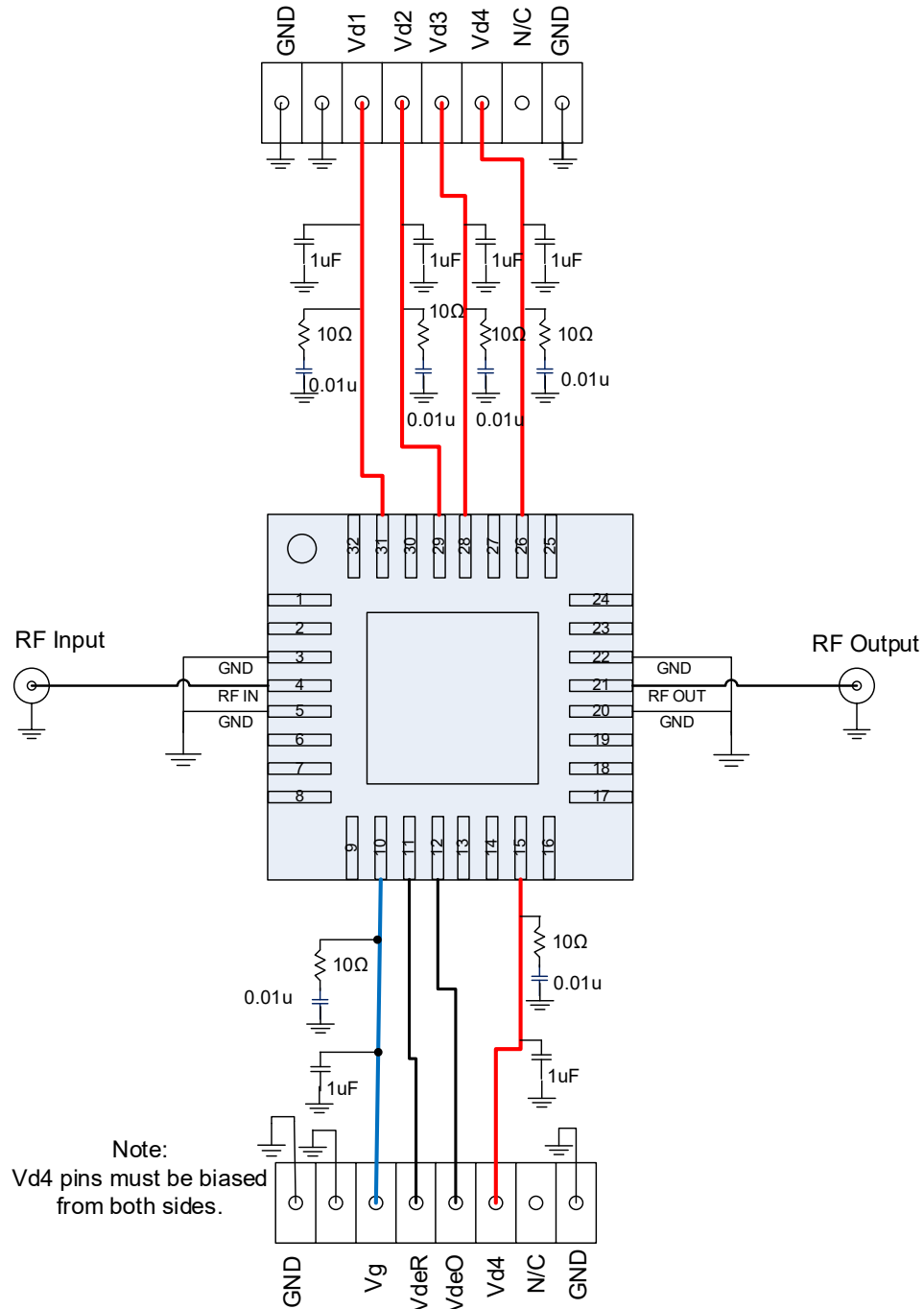

## Sample Application Board Design

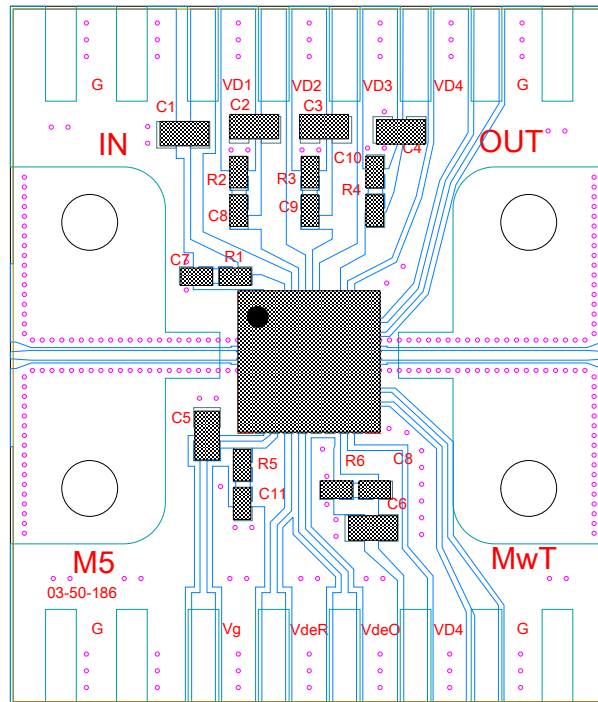

Part	Description
C1, C2, C3, C4, C5, C6	1uF capacitor (0603)
C7, C8, C9, C10, C11, C12	0.01uF Capacitor (0402)
R1, R2, R3, R4, R5, R6	10Ω Resistor (0402)
Board Material	Rogers RO4350B, 10 Mil Dielectric Thickness ½ oz. Copper Cladding, Copper-Filled Via Holes



## Biasing and Operation

The recommended bias conditions for optimum performance for the **MMA-243034D-M5** are  $V_{DD} = 6.0V$ ,  $I_{dq} = 1600mA$ . The gate voltage ( $V_g$ ) must be applied prior to the drain voltages ( $V_{d1}, V_{d2}, V_{d3}, V_{d4}$ ) during power up and removed after the drain voltages during power down. A single DC gate supply connected to  $V_g$  will bias all the amplifier stages. Muting can be accomplished by setting  $V_g$  to the pinch-off voltage ( $V_p = -2V$ ).  $V_{d4}$  must be connected to both  $V_{d1}$  pins.

## Assembly and Handling

GaAs MMICs are ESD sensitive. ESD preventive measures must be employed in all aspects of storage, handling, and assembly.

## Sample Application Board Design:

Proper heatsinking and board mounting pattern with filled thermal vias are recommended for optimum performance. An electronic drawing of the sample board layout is available upon request from *MwT* Sales & Application Engineering.

