

MDA. Fluted grip knobs

Technopolymer, assembly with screw



- 1
- 2
- 3
- 4
- 5
- 6
- 7
- 8
- 9
- 10
- 11
- 12
- 13
- 14
- 15
- 16
- 17
- 18

MATERIAL

Glass-fibre reinforced polyamide based (PA) technopolymer, black colour, matte finish.

CLOSING CAP

Glass-fibre reinforced polyamide based (PA) technopolymer, light grey colour, press-fit assembly.

STANDARD EXECUTION

Assembly by means of hexagon head screws or standard lock nuts (not supplied) to put in place inside the knob by pressing.

SPECIAL EXECUTIONS ON REQUEST

- On the surface of the closing cap words, marks, graphic symbols, etc. can be tampoprinted in colours.
- Closing cap in other colours.

ASSEMBLY INSTRUCTIONS

1. The base of the knob should rest on a flat surface.
 2. Insert the screw or the lock nut into the knob hole by means of a thrust tool.
 3. Push until the insert is completely fitted in.
 4. Assemble the snap-in closing cap.
- The screw or nut assembly can be also made by fitting into the hexagon socket and screw-on the knob, until firmly in place.



Conversion Table 1 mm = 0.039 inch					
D		d		s	
mm	inch	mm	inch	mm	inch
34	1.34	6	0.24	10	0.39
42	1.65	8	0.31	13	0.51
53	2.09	10	0.39	17	0.67

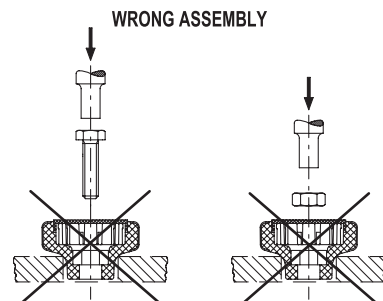
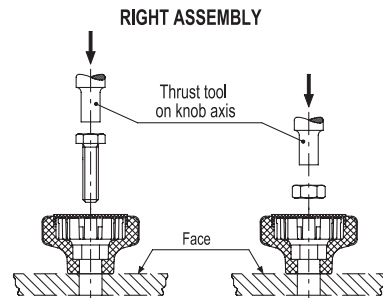
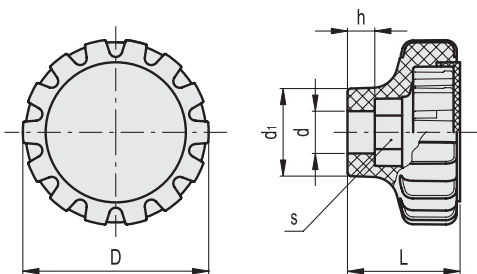

Code	Description	D	d	L	d1	h	s	⚖️
37951	MDA.30 EH-6	34	6	21	16	5	10	14
37956	MDA.40 EH-8	42	8	26	19	5	13	18
37961	MDA.50 EH-10	53	10	32	24	5	17	23

Clamping knobs