

**MATERIAL**

Weldable black-oxide steel.

**PINS**

Ground and hardened steel.

**FEATURES AND APPLICATIONS**

All articulated joints are lubricated with special grease resistant to high temperatures.

MCR toggle clamps are particularly suitable for applications on moulds for plastic materials and in rotational moulding.

The position of the threaded screw can be adjusted according to specific applications.

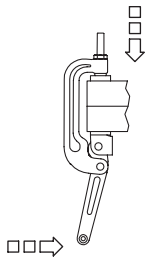
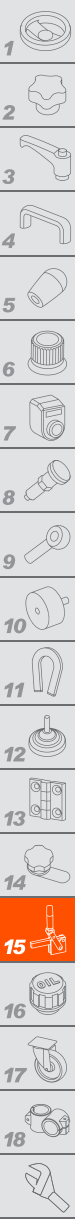

Application example

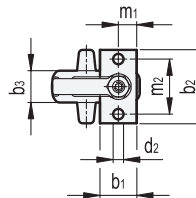
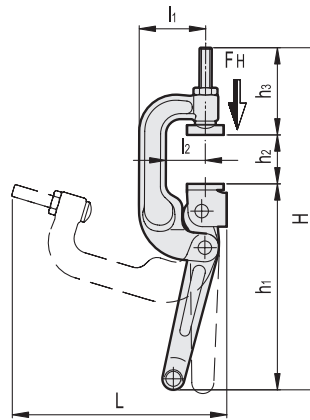
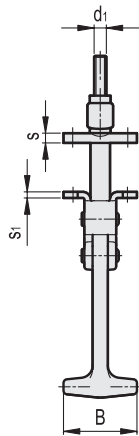
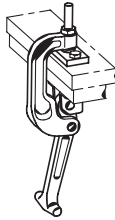

**METRIC**

Code	Description	B	b1	b2	b3	d1	d2	H	h1	h2	h3	L	l1	l2	m1	m2	s	s1	FH [N]*	⚖
GG.AL758	MCR.1540	60	30	60	26	M10	8.5	280	168	40	71	173	54	32	15	45	8	5	15000	1110
GG.AL760	MCR.1575	60	30	60	26	M10	8.5	315	168	75	71	207	54	32	15	45	8	5	15000	1190

\* Holding force.

