

- 1
- 2
- 3
- 4
- 5
- 6
- 7
- 8
- 9
- 10
- 11
- 12
- 13
- 14
- 15
- 16
- 17
- 18

DIAMOND CUT KNURLED KNOB

Glass-fibre reinforced polyamide based (PA) technopolymer, black colour, matte finish.

Moulded-in spindle.

BEZEL

Technopolymer. Moulded over the window.

WINDOW

Transparent polyamide based (PA-T) technopolymer (practically unbreakable). Resistant to solvents, oils, greases and other chemical agents (avoid contact with alcohol during cleaning operations).

DIAL

Natural matte anodised aluminium.
Clockwise or anti-clockwise graduation, black colour.

STANDARD EXECUTION

Black-oxide steel boss, H7 reamed blind hole, fitting to shaft by means of a supplied grub screw with hexagon socket and cup end UNI 5929-85.

READING

Five-digits roller counter and one red pointer which turns on the graduated dial. The digit of the red roll shows the decimal values, while the pointer shows the hundredth.

The display indicates the displacement of the mechanism controlled by the spindle from the start position (0). One complete turn of the machine spindle corresponds to a turn of the knob and consequently to a turn of the red pointer. A turn of the red pointer corresponds to a determinate reading on the counter (see "reading on the counter after one revolution of the red pointer" in the table).
Ballrace rotation: maximum reading accuracy.

IP PROTECTION

The ultrasonic welding of the window to the case guarantees the complete sealing with IP 67 protection class, see table EN 60529 (on page A-19).

FEATURES AND APPLICATIONS

The knobs with built-in gravity position indicator are suitable on spindles with horizontal or max 60° inclined axis.

SPECIAL EXECUTIONS ON REQUEST

- No pointer
- Plain dial
- Special dial with logo or customised graduations
- Filling with paraffin oil, maximum continuous working temperature 40°C
- Special readings after one revolution.

INSTRUCTIONS OF USE

See GW12 (on page 467).



ELESA Original design

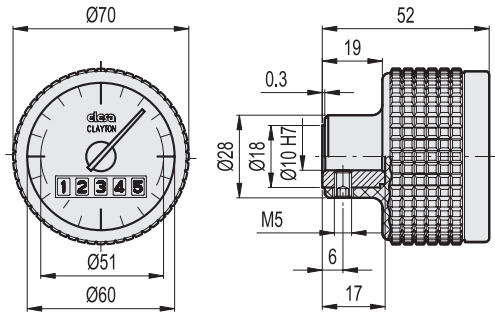

Example of description for ordering

MBT.70-GW12 - 00002 - D

Reading on the counter after one revolution of the red pointer

00002	0000.2	000.02	00.002
00002	0000.2	000.02	00.002
00005	0000.5	000.05	00.005
00008	0000.8	000.08	00.008
00010	0001.0	000.10	00.010
00012	0001.2	000.12	00.012
00012(5)	0001.2(5)	000.12(5)	00.012(5)
00020	0002.0	000.20	00.020
00025	0002.5	000.25	00.025
00030	0003.0	000.30	00.030
00035	0003.5	000.35	00.035
00040	0004.0	000.40	00.040
00050	0005.0	000.50	00.050

Dial Graduation Number
20
50
40
100
60
100
40
50
60
70
80
100

Graduation

Graduated dial resolution

Divide the reading of the counter for the number of graduations of the dial.

Example: 00002 / 20=0.1

Increasing graduation

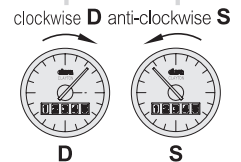

Position indicators