



# MAX9588 Evaluation Kit

## General Description

The MAX9588 evaluation kit (EV kit) is an assembled and tested PCB that demonstrates the MAX9588 triple-channel, standard-definition video filter amplifier with AC-coupled inputs. The EV kit operates from 2.7V to 3.6V with a 2V/V fixed gain.

## Component List

DESIGNATION	QTY	DESCRIPTION
C1	1	10 $\mu$ F $\pm$ 10%, 6.3V X5R ceramic capacitor (0805) Murata GRM21BR60J106K TDK C2012X5R0J106K
C2–C5	4	0.1 $\mu$ F $\pm$ 10%, 16V X7R ceramic capacitors (0603) Taiyo Yuden EMK107BJ104KA TDK C1608X7R1C104KT or equivalent
C6, C7, C8	0	Not installed, aluminum electrolytic capacitors (6.3mm x 6.0mm)
IN_A, IN_B, IN_C, OUT_A, OUT_B, OUT_C	6	75 $\Omega$ BNC PCB-mount jack connectors
R1–R6	6	75 $\Omega$ $\pm$ 1% resistors (0603)
R7, R8, R9	3	0 $\Omega$ resistors (0603)
U1	1	MAX9588AZT+ (8-pin $\mu$ MAX)
—	1	PCB: MAX9588 Evaluation Kit+

## Component Suppliers

SUPPLIER	PHONE	WEBSITE
Murata Mfg. Co., Ltd.	770-436-1300	www.murata.com
Taiyo Yuden	800-348-2496	www.t-yuden.com
TDK Corp.	847-803-6100	www.component.tdk.com

**Note:** Indicate that you are using the MAX9588 when contacting these component suppliers.

## Features

- ◆ Triple Channel (CVBS and S-Video)
- ◆ AC-Coupled Inputs
- ◆ 7MHz  $\pm$ 1dB Passband
- ◆ 40dB Attenuation at 27MHz
- ◆ 2.7V to 3.6V Single-Supply Operation
- ◆ Fully Assembled and Tested

## Ordering Information

PART	TEMP RANGE	IC PACKAGE
MAX9588EVKIT+	0°C to +70°C*	8 $\mu$ MAX <sup>®</sup>

+ Denotes a lead-free and RoHS-compliant EV kit.

\* This limited temperature range applies to the EV kit PCB only.

The MAX9588 IC temperature range is -40°C to +125°C.

$\mu$ MAX is a registered trademark of Maxim Integrated Products, Inc.

## Quick Start

### Recommended Equipment

- A DC power supply capable of supplying a voltage between 2.7V to 3.6V at 500mA
- CVBS and S-video signal generator
- Video measurement equipment (e.g., Tektronix VM700T or equivalent)

### Procedure

The MAX9588 EV kit is fully assembled and tested. Follow the steps below to verify board operation.

**Caution: Do not turn on the power supply until all connections are completed.**

- 1) Connect the power supply to the pads labeled VDD and GND on the MAX9588 EV kit.
- 2) Connect the desired test signals from the video signal generator to the IN\_A/CVBS, IN\_B/LUMA(Y), and IN\_C/CHROMA(C) BNC connectors.
- 3) Connect the output signals from the OUT\_A, OUT\_B, and OUT\_C BNC connectors to the inputs of the video measurement equipment.
- 4) Turn on the power supply and verify the output signals.

Evaluates: MAX9588

# MAX9588 Evaluation Kit

## Detailed Description

The MAX9588 EV kit demonstrates the MAX9588 low-power, triple-channel video filter amplifier with integrated reconstruction filters. The EV kit operates from 2.7V to 3.6V with a 2V/V fixed gain.

The MAX9588 has  $\pm 1\text{dB}$  (typ) passband flatness at 7MHz and 40dB attenuation at 27MHz and the outputs can be DC-coupled to a  $75\Omega$  load, which is the equivalent of two video loads, or AC-coupled to a  $150\Omega$  load.

## AC-Coupling the Output

The output of the MAX9588 can be AC-coupled. To keep the highpass formed by the  $150\Omega$  equivalent resistance of the video transmission line to a corner frequency of 4.8Hz or lower, remove the  $0\Omega$  resistors on R7, R8, and R9 and install  $\geq 220\mu\text{F}$  coupling capacitors on the C6, C7, and C8 pads.

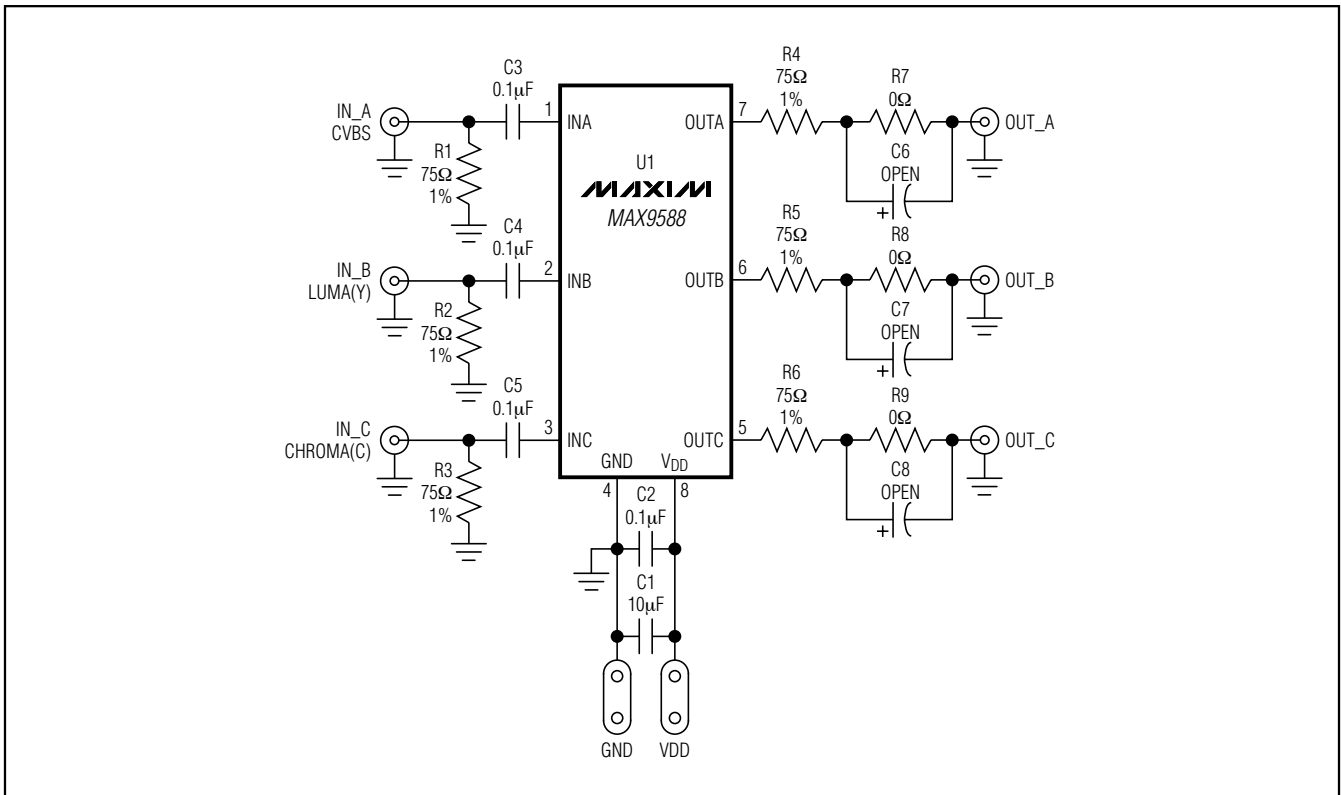

Figure 1. MAX9588 EV Kit Schematic

# MAX9588 Evaluation Kit

Evaluates: MAX9588

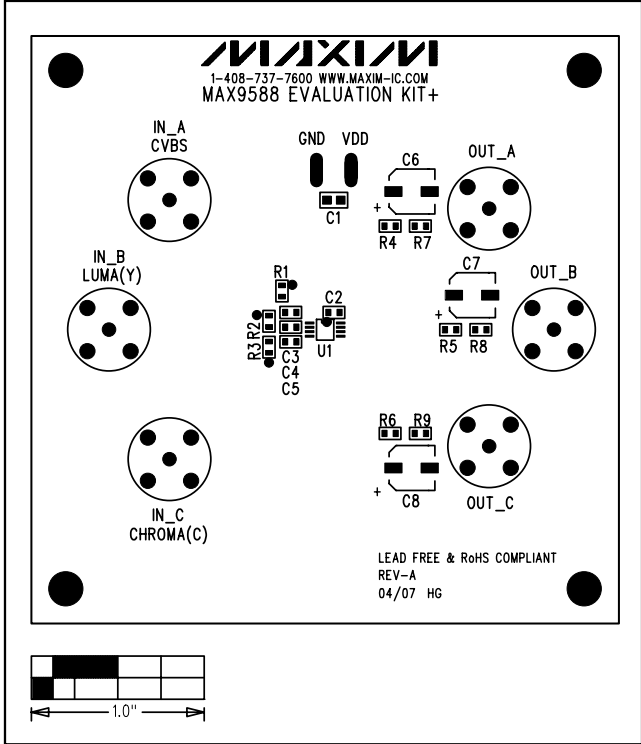

Figure 2. MAX9588 EV Kit Component Placement Guide—Component Side

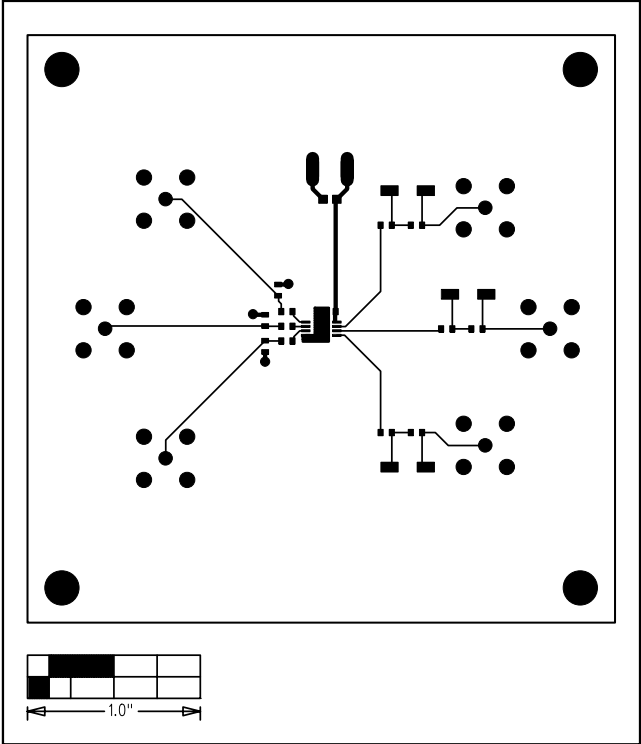

Figure 3. MAX9588 EV Kit PCB Layout—Component Side

# **MAX9588 Evaluation Kit**

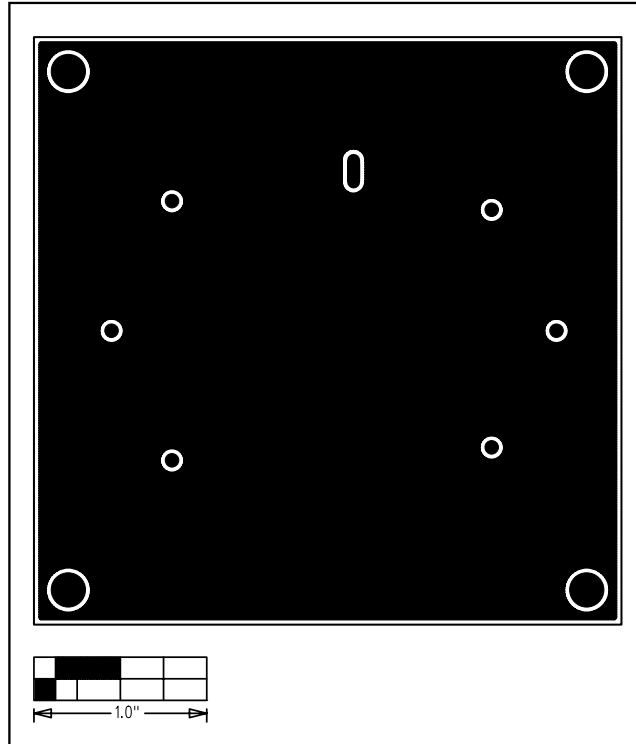

Figure 4. MAX9588 EV Kit PCB Layout—Solder Side

Maxim cannot assume responsibility for use of any circuitry other than circuitry entirely embodied in a Maxim product. No circuit patent licenses are implied. Maxim reserves the right to change the circuitry and specifications without notice at any time.

4 \_\_\_\_\_ **Maxim Integrated Products, 120 San Gabriel Drive, Sunnyvale, CA 94086 408-737-7600**