

ITEM #	PART #	QTY	DESCRIPTION
1	AJ-117BR-9	1	BUSHING - 1/4"
2	AJ-117BR-10	1	WASHER- 1/4"
3	AJ-117BR-11	1	STUD, SHELL - 1/4"
4	AJ-117BR-15	1	SPRING - 1/4"
5	MAP-50-03	1	WASHER, RUBBER
6	MAP-57-01	1	STRAIN RELIEF
7	MAP-50-10	1	PLUG INSERT, 7 COND.
8	MAP-50-53	1	PLUG HOUSING ASS'Y
9	MAP-50-24	1	NUT ADAPTER
10	MAP-50-27	1	FIT SEAL - PLUG

B MAP-57-30

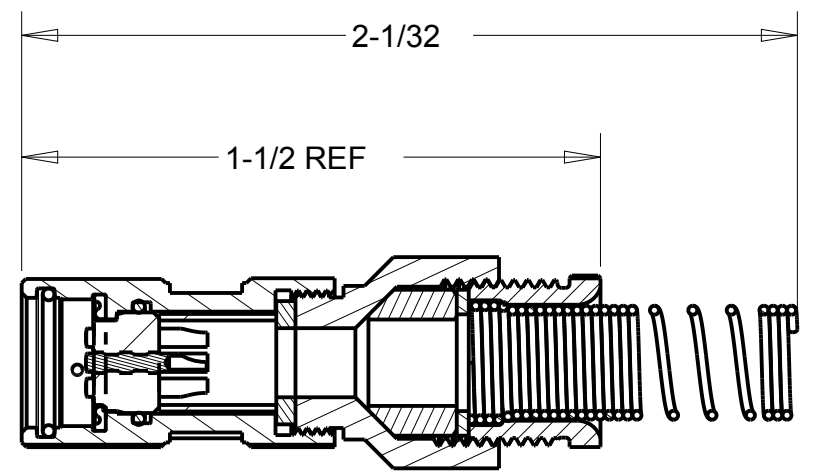
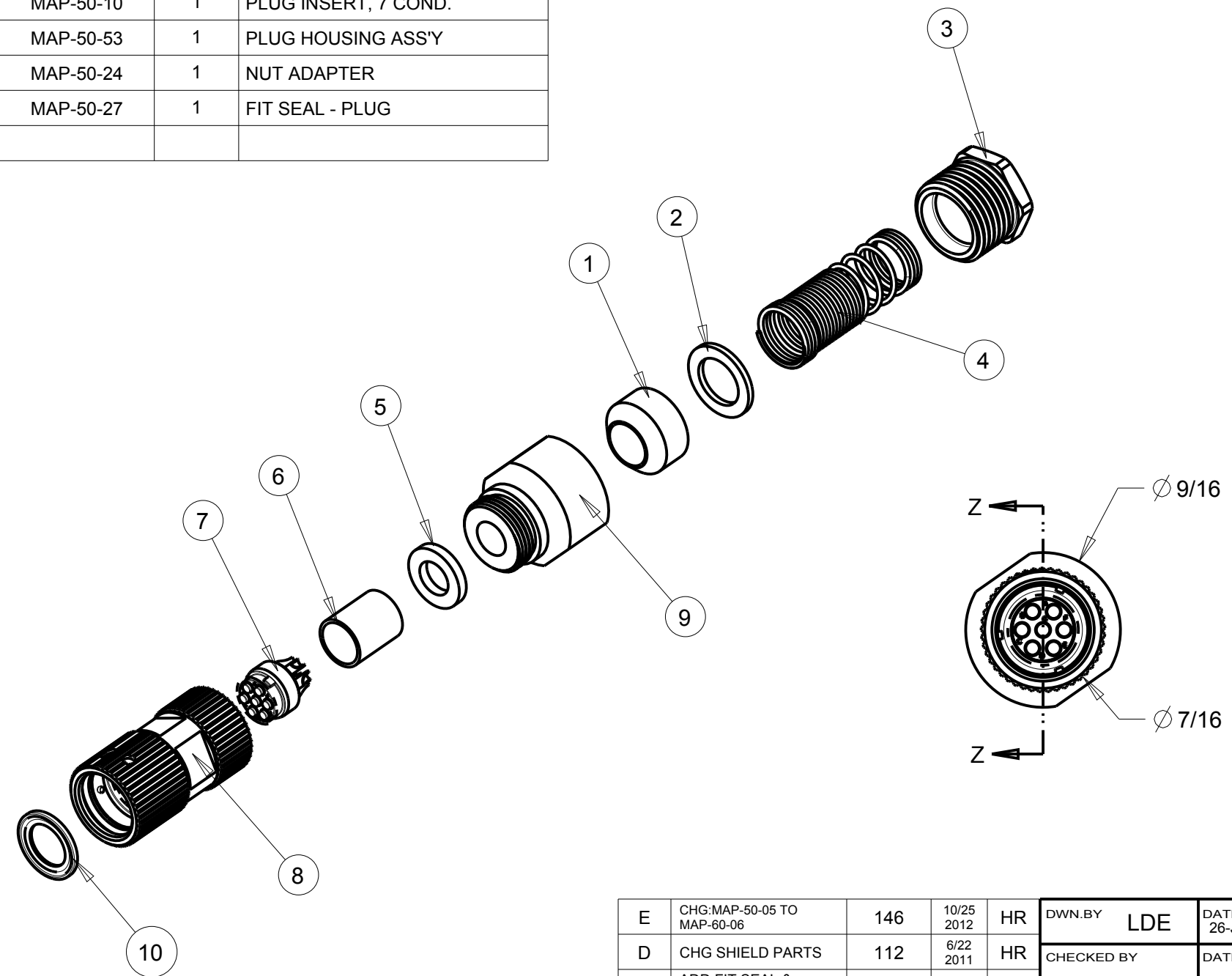
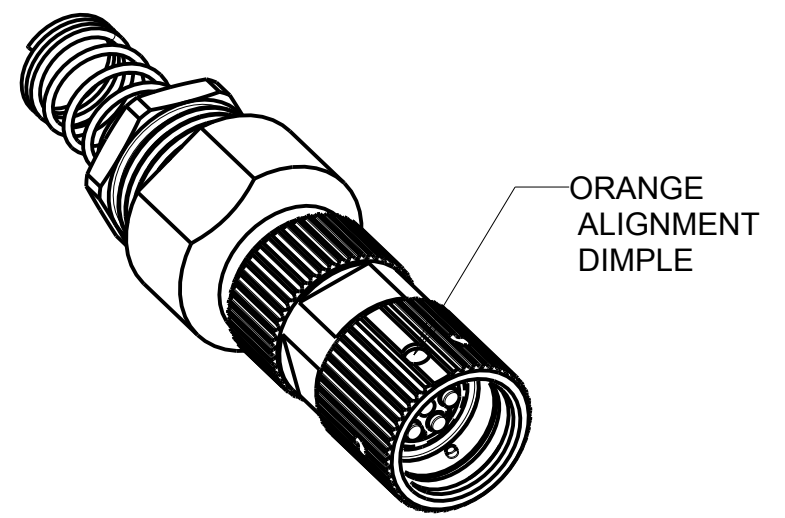

SECTION Z-Z

THIS DOCUMENT CONTAINS PROPRIETARY INFORMATION OF NEXUS, INCORPORATED AND SUCH INFORMATION MAY NOT BE DISCLOSED TO OTHERS FOR ANY PURPOSE OR USED FOR ANY PURPOSE WITHOUT THE WRITTEN CONSENT OF NEXUS.

<table border="1"> <tr> <td>E</td> <td>CHG:MAP-50-05 TO MAP-60-06</td> <td>146</td> <td>10/25 2012</td> <td>HR</td> </tr> <tr> <td>D</td> <td>CHG SHIELD PARTS</td> <td>112</td> <td>6/22 2011</td> <td>HR</td> </tr> <tr> <td>C</td> <td>ADD FIT SEAL & ALIGNMENT MARK WAS A SIZE - ADD MAT'L</td> <td></td> <td>06/04 2010</td> <td></td> </tr> <tr> <td>B</td> <td>SHIELDING WASHERS</td> <td></td> <td>03/25 2010</td> <td></td> </tr> <tr> <td>F</td> <td>CHG: MAP-60-06 TO MAP-57-01, ADD: 2-1/32</td> <td>152</td> <td>1/24 2013</td> <td>HR</td> </tr> </table>					E	CHG:MAP-50-05 TO MAP-60-06	146	10/25 2012	HR	D	CHG SHIELD PARTS	112	6/22 2011	HR	C	ADD FIT SEAL & ALIGNMENT MARK WAS A SIZE - ADD MAT'L		06/04 2010		B	SHIELDING WASHERS		03/25 2010		F	CHG: MAP-60-06 TO MAP-57-01, ADD: 2-1/32	152	1/24 2013	HR	<table border="1"> <tr> <td>DWN.BY</td> <td>LDE</td> <td>DATE</td> <td>26-Jan-10</td> </tr> <tr> <td>CHECKED BY</td> <td></td> <td>DATE</td> <td></td> </tr> <tr> <td>APPR.BY</td> <td></td> <td>DATE</td> <td></td> </tr> </table>		DWN.BY	LDE	DATE	26-Jan-10	CHECKED BY		DATE		APPR.BY		DATE		<table border="1"> <tr> <td colspan="2">MATERIAL</td> </tr> <tr> <td colspan="2">FINISH</td> </tr> <tr> <td>WEIGHT</td> <td>SCALE = 2.00 :1</td> </tr> <tr> <td colspan="2">TITLE</td> </tr> <tr> <td colspan="2">7 COND. PLUG-1/4" CABLE</td> </tr> <tr> <td colspan="2">DO NOT SCALE DWG.</td> </tr> </table>		MATERIAL		FINISH		WEIGHT	SCALE = 2.00 :1	TITLE		7 COND. PLUG-1/4" CABLE		DO NOT SCALE DWG.		<table border="1"> <tr> <td colspan="2">NEXUS STAMFORD, CONN</td> </tr> <tr> <td>SIZE</td> <td>DWG. NO.</td> </tr> <tr> <td>B</td> <td>MAP-57-30</td> </tr> </table>		NEXUS STAMFORD, CONN		SIZE	DWG. NO.	B	MAP-57-30
E	CHG:MAP-50-05 TO MAP-60-06	146	10/25 2012	HR																																																													
D	CHG SHIELD PARTS	112	6/22 2011	HR																																																													
C	ADD FIT SEAL & ALIGNMENT MARK WAS A SIZE - ADD MAT'L		06/04 2010																																																														
B	SHIELDING WASHERS		03/25 2010																																																														
F	CHG: MAP-60-06 TO MAP-57-01, ADD: 2-1/32	152	1/24 2013	HR																																																													
DWN.BY	LDE	DATE	26-Jan-10																																																														
CHECKED BY		DATE																																																															
APPR.BY		DATE																																																															
MATERIAL																																																																	
FINISH																																																																	
WEIGHT	SCALE = 2.00 :1																																																																
TITLE																																																																	
7 COND. PLUG-1/4" CABLE																																																																	
DO NOT SCALE DWG.																																																																	
NEXUS STAMFORD, CONN																																																																	
SIZE	DWG. NO.																																																																
B	MAP-57-30																																																																
<table border="1"> <tr> <td>LET</td> <td>REVISION</td> <td>CN #</td> <td>DATE</td> <td>CHK</td> <td>LET.</td> <td>REVISION</td> <td>CN #</td> <td>DATE</td> <td>CHK.</td> </tr> </table>					LET	REVISION	CN #	DATE	CHK	LET.	REVISION	CN #	DATE	CHK.	<table border="1"> <tr> <td colspan="2">UNLESS OTHERWISE SPECIFIED: DIMENSIONS ARE IN INCHES &/OR (mm)</td> </tr> <tr> <td>TOLERANCES:</td> <td></td> </tr> <tr> <td>DECIMAL: .XX[X.X] .XXX[X.XX]</td> <td></td> </tr> <tr> <td>± .01[0.3] ± .003[0.08]</td> <td></td> </tr> <tr> <td>FRACTION: X/X</td> <td>ANGLES: .X</td> </tr> <tr> <td>± 1/64</td> <td>± .5°</td> </tr> </table>		UNLESS OTHERWISE SPECIFIED: DIMENSIONS ARE IN INCHES &/OR (mm)		TOLERANCES:		DECIMAL: .XX[X.X] .XXX[X.XX]		± .01[0.3] ± .003[0.08]		FRACTION: X/X	ANGLES: .X	± 1/64	± .5°	<table border="1"> <tr> <td colspan="2">SHEET 1 OF 1</td> </tr> </table>		SHEET 1 OF 1																																		
LET	REVISION	CN #	DATE	CHK	LET.	REVISION	CN #	DATE	CHK.																																																								
UNLESS OTHERWISE SPECIFIED: DIMENSIONS ARE IN INCHES &/OR (mm)																																																																	
TOLERANCES:																																																																	
DECIMAL: .XX[X.X] .XXX[X.XX]																																																																	
± .01[0.3] ± .003[0.08]																																																																	
FRACTION: X/X	ANGLES: .X																																																																
± 1/64	± .5°																																																																
SHEET 1 OF 1																																																																	