

ITEM #	PART #	QTY	DESCRIPTION
1	MAJ-60-12	1	OM PLUG HOUSING
2	MAJ-60-08P	1	JACK INSERT, 10 COND
3	MAP-60-06	1	STRAIN RELIEF
4	MAP-60-07	1	WASHER, RUBBER
5	MAP-60-08	1	NUT, ADAPTER
6	AJ-117BR-9	1	BUSHING - 1/4
7	AJ-117BR-10	1	WASHER - 1/4
8	AJ-117BR-15	1	SPRING - 1/4
9	AJ-117BR-11	1	STUD, SHELL - 1/4

B MAJ-60-30CP

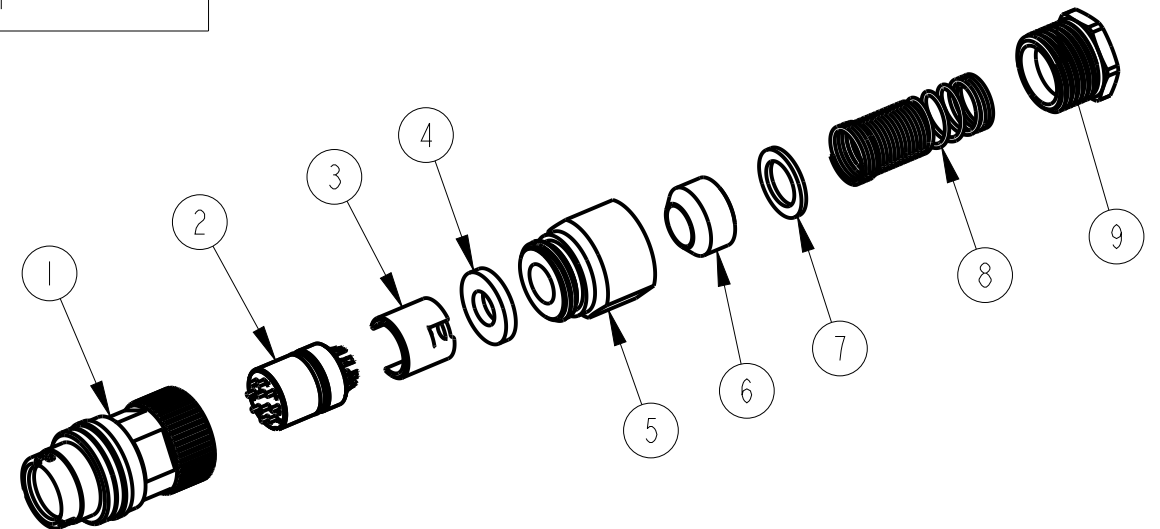

NOTES:
1) ORANGE ALIGNMENT DIMPLE

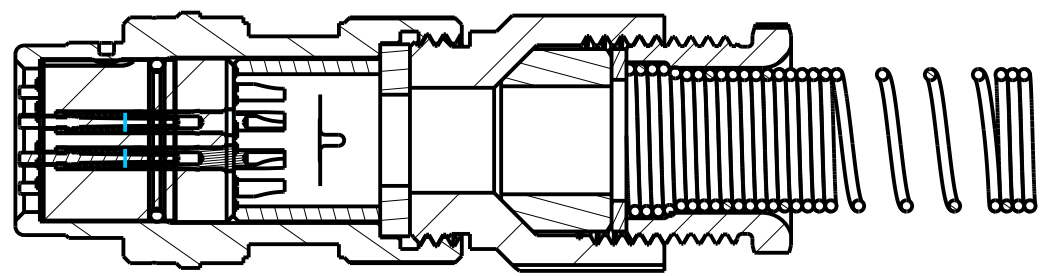
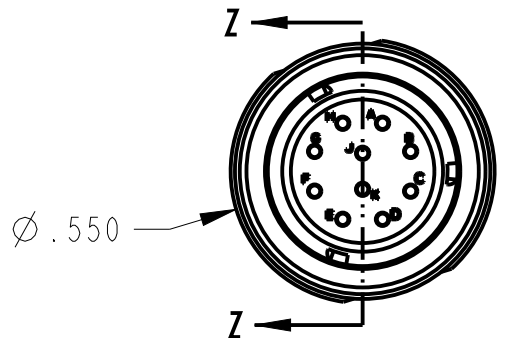
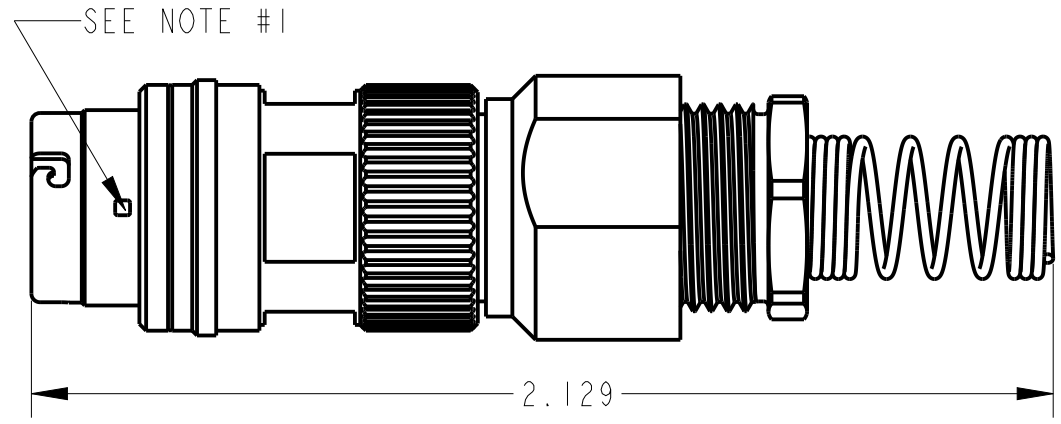

SECTION Z-Z

THIS DOCUMENT CONTAINS PROPRIETARY INFORMATION OF NEXUS, INCORPORATED AND SUCH INFORMATION MAY NOT BE DISCLOSED TO OTHERS FOR ANY PURPOSE OR USED FOR ANY PURPOSE WITHOUT THE WRITTEN CONSENT OF NEXUS.

DWN. BY		HR	DATE		8/11/17	MATERIAL	
CHECKED BY			DATE			FINISH	
APPR. BY			DATE			WEIGHT	SCALE = 2.00 : 1
C	REPLACE CONTACT INSERT WAS MAJ-60-01	1259	10/11 2019	BAM	TITLE		NEXUS STAMFORD, CONN
B	CHG: MAP-60-06 TO MAP-60-06C	243	9/21 2017	HR	10-COND RECEPTACLE $\varnothing .250$ CABLE		
A	NEW RELEASE		8/11 2017	HR	DO NOT SCALE DWG.		SIZE B
LET.	REVISION	CN #	DATE	CHK.	SHEET 1 OF 1		DWG. NO. MAJ-60-30CP

UNLESS OTHERWISE SPECIFIED:
DIMENSIONS ARE IN INCHES &/OR [mm]
TOLERANCES:
DECIMAL: .XX[X.X] .XXX[X.XX]
 ±.01[0.3] ±.003[0.08]
FRACTION: X/X ANGLES: .X
 ±1/64 ±.5°