

- 1
- 2
- 3
- 4
- 5
- 6
- 7
- 8
- 9
- 10
- 11
- 12
- 13
- 14
- 15
- 16
- 17
- 18

PASS-THROUGH HANDLE SHANKS

Glass-fibre reinforced polyamide based (PA) technopolymer, black colour, matte finish.

To prevent tube rotation, screw up to the stop the self-tapping screw $\varnothing 3,9 \times 6,5$ arranged inside the handle shank.

CLOSING CAPS

Polyamide based (PA) technopolymer, black colour, matte finish.

Included in the supply, push-fit assembly (Fig.1), removable by a screwdriver.

Available also as accessories sold separately (see table ECS).

Code	Description
29882-C9	ECS.T2-C9

TUBE

AISI 304 stainless steel.

END CAPS

Polyamide based (PA) technopolymer, matte finish.

MOUNTING

Pass-through hole for front or rear mounting by means of cylindrical-head screws with hexagon socket, hexagonal-head screws or standard nuts.

TECHNICAL DATA

Tubular handles are characterised by a variable handle shank, the handle shanks being adjustable on the tube by means of the set screw.

Tensile stress: F values reported in the table are the result of breaking tests carried out with the appropriate dynamometric equipment under the test conditions shown in the figure with ambient temperature.

SPECIAL EXECUTIONS ON REQUEST

- Different lengths.
- Closing caps in different colours.



ELESA Original design

Fig.1

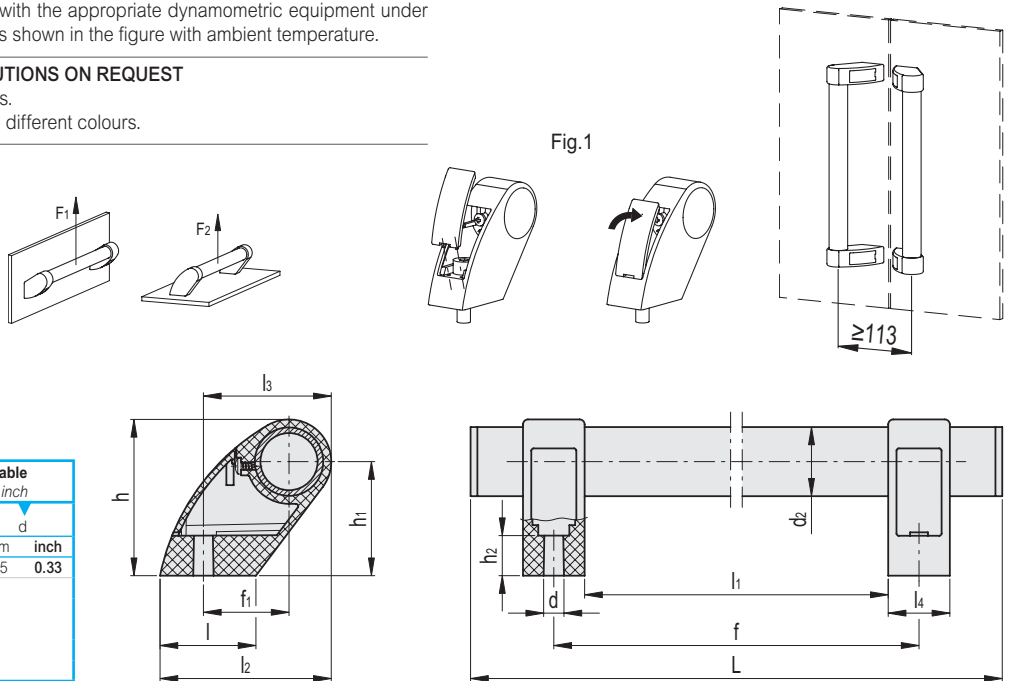

Conversion Table			
1 mm = 0,039 inch			
L		d	
mm	inch	mm	inch
324	12.75	8.5	0.33
374	14.72		
424	16.69		
524	20.63		
624	24.57		
724	28.50		

INOX STAINLESS STEEL METRIC

Code	Description	d2	f _{max} ±1	f1	L	d	h	h1	h2	l	l1 max.	l2	l3	l4	F1 [N]*	F1 [N]#	F2 [N]*	F2 [N]#	Δ
36907	M.1053 P/30-295-SST	30	295	37.5	324	8.5	68.5	50	17.5	42	268	75	56	27	2600	4700	3500	5600	231
36917	M.1053 P/30-345-SST	30	345	37.5	374	8.5	68.5	50	17.5	42	318	75	56	27	2500	4600	3300	5200	249
36927	M.1053 P/30-395-SST	30	395	37.5	424	8.5	68.5	50	17.5	42	368	75	56	27	2100	3900	3000	4500	266
36937	M.1053 P/30-495-SST	30	495	37.5	524	8.5	68.5	50	17.5	42	468	75	56	27	1950	3000	2850	3600	301
36947	M.1053 P/30-595-SST	30	595	37.5	624	8.5	68.5	50	17.5	42	568	75	56	27	1650	2850	2100	3600	336
36957	M.1053 P/30-695-SST	30	695	37.5	724	8.5	68.5	50	17.5	42	668	75	56	27	1500	2400	1800	2800	371

Lift & Pull handles

* Maximum working load # Load at breakage.