

Approved	Checked	Designed	DEVELOPMENT SPECIFICATION			
<i>K. Sarada</i>	<i>S. Takami</i>	<i>M. Nijouma</i>		P/N: LNV810105A	8	1

TYPE	10-ELEMENT BAR GRAPH ARRAY (Lighting color:Orange)																		
MATERIAL	GaAsP																		
APPLICATION	Indicators																		
OUTLINE	See attached drawing																		
CONNECTION	See attached drawing																		
ABSOLUTE MAXIMUM RATINGS	<table border="1"> <tr> <td>P/seg</td> <td>*1 I_{FP}/seg</td> <td>I_{FDC}/seg</td> <td>V_R</td> <td>Topr</td> <td>Tstg</td> </tr> <tr> <td>60</td> <td>100</td> <td>20</td> <td>3</td> <td>-25~+80</td> <td>-30~+85</td> </tr> <tr> <td>mW</td> <td>mA</td> <td>mA</td> <td>V</td> <td>°C</td> <td>°C</td> </tr> </table>	P/seg	*1 I _{FP} /seg	I _{FDC} /seg	V _R	Topr	Tstg	60	100	20	3	-25~+80	-30~+85	mW	mA	mA	V	°C	°C
P/seg	*1 I _{FP} /seg	I _{FDC} /seg	V _R	Topr	Tstg														
60	100	20	3	-25~+80	-30~+85														
mW	mA	mA	V	°C	°C														
CONDITION	Ta =25±3° C																		

Test Specification

Item	Symbol	condition	Typ.	Limit		Unit
				Min.	Max.	
Forward Voltage	V _F	I _F =10mA	1.93		2.8	V
Reverse leakage Current	I _R	V _R = 3V			10	μA
Luminous intensity per LED	*2 I _o	I _{FDC} =10mA	1000	300		μcd
Peak Emission Wavelength	λ _p	I _{FDC} =10mA	630			nm
Spectral Line Half Width	Δλ	I _{FDC} =10mA	40			nm

*1 The Condition of I_{FP} is duty 10% , pulse width 1ms.

*2 I_o scattering of the same element in the same case I_o max/min ≤ 2.5
(condition is I_{FDC} =10mA/chip)

SEP. 25. 1998			
---------------	--	--	--

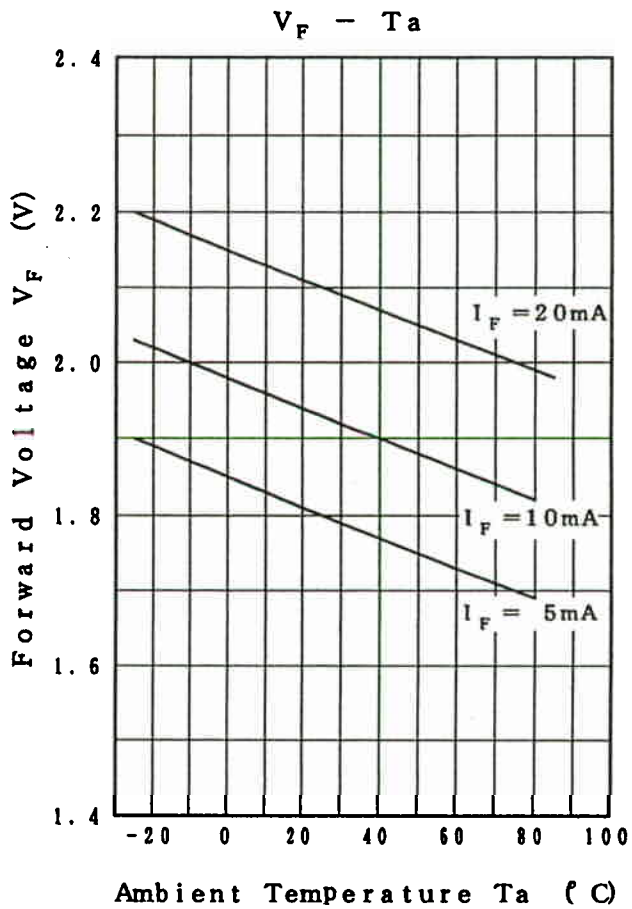
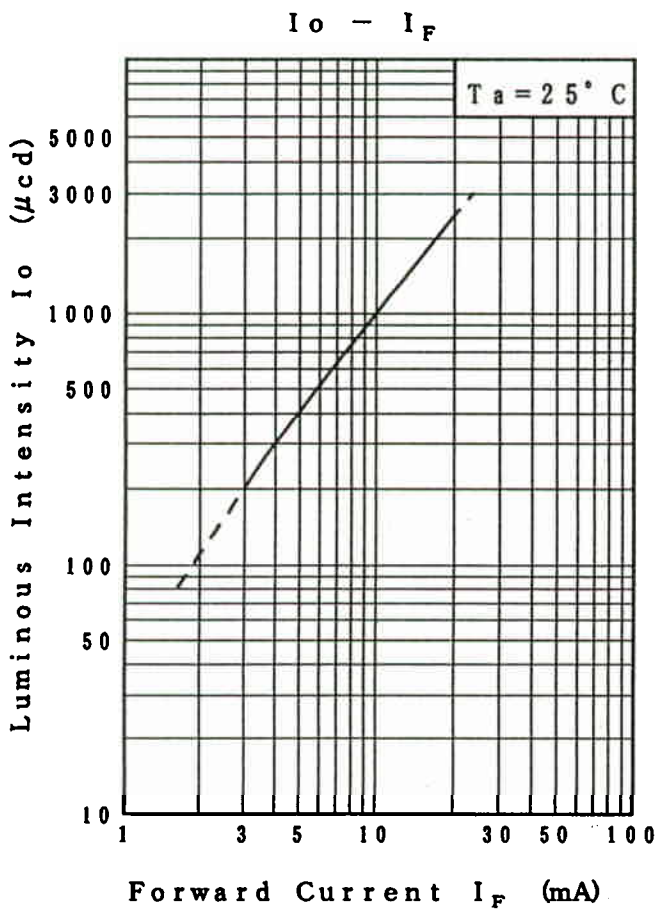
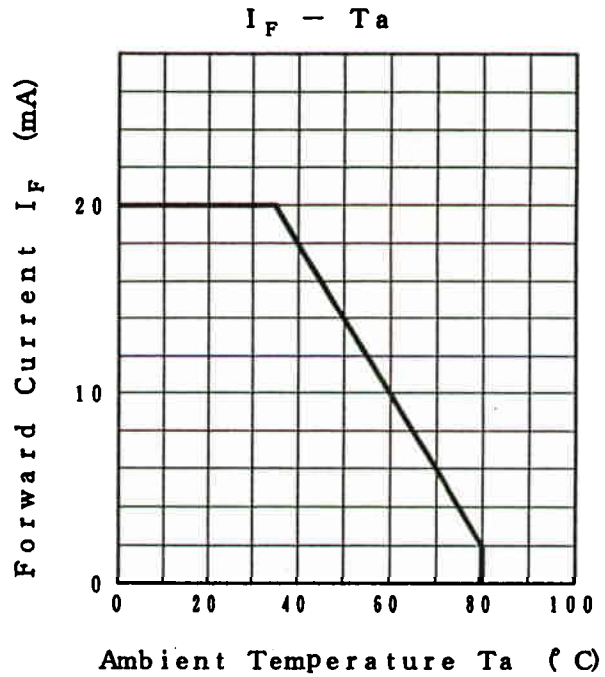
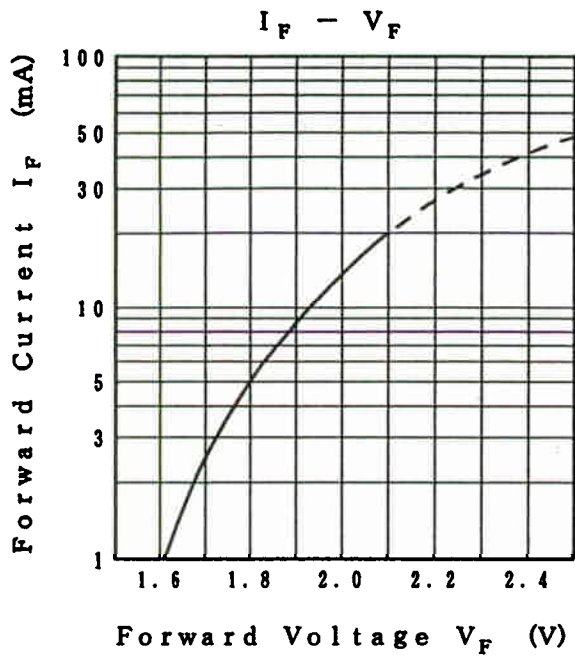

Approved Checked Designed

K. Senech
S. T...
M. P...

DEVELOPMENT SPECIFICATION

P/N: LNV810105A

8

3

$I_o - T_a$

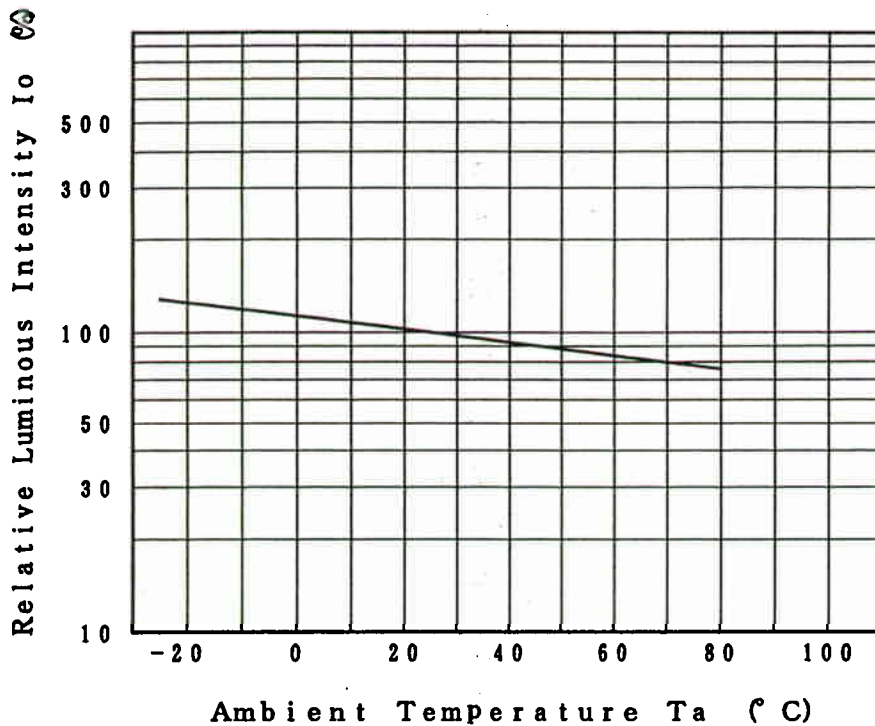

Relative Luminous Intensity
Wavelength Characteristics

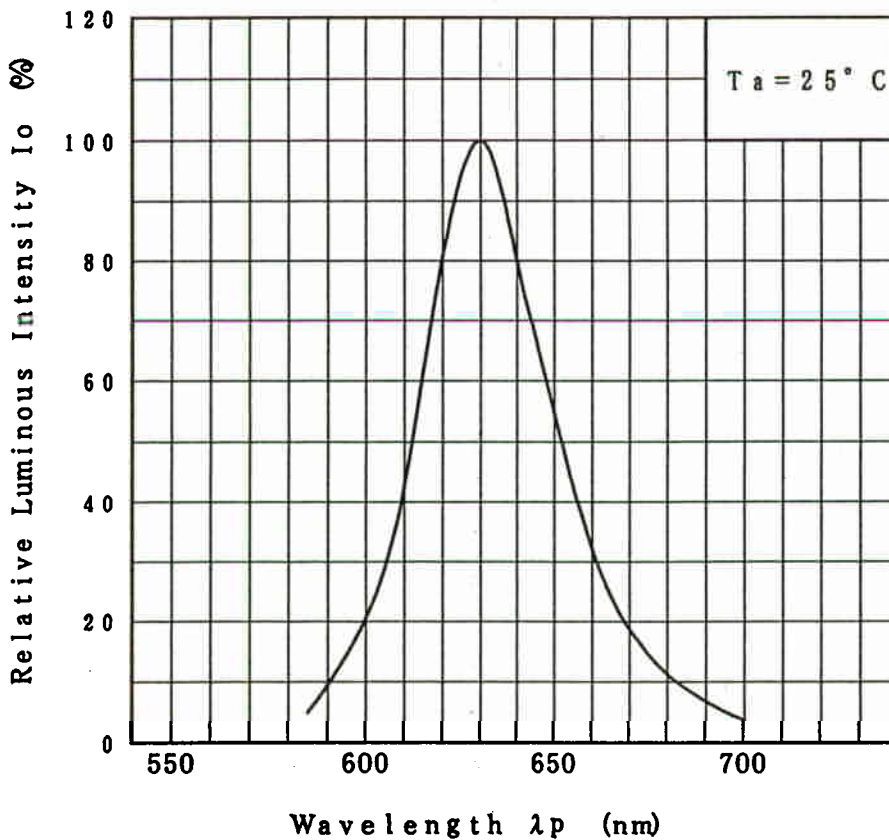

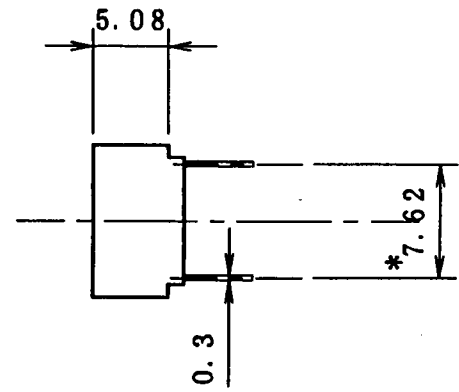
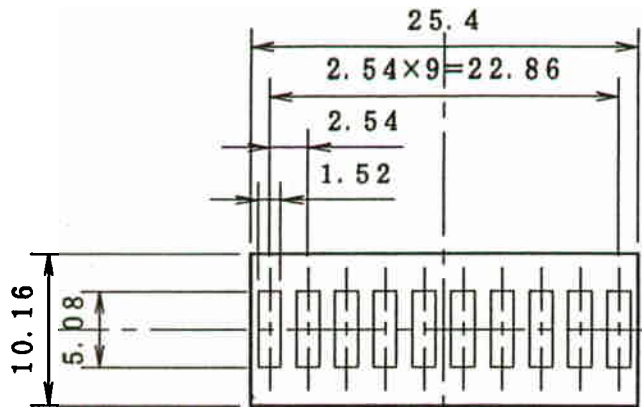

Gray coating

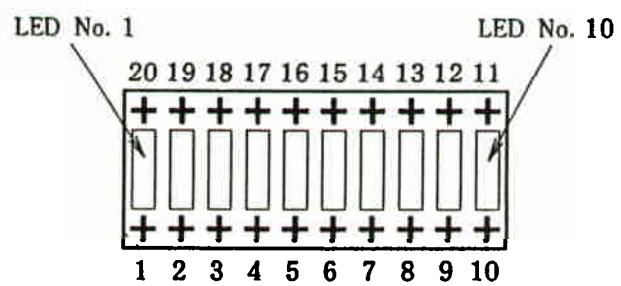
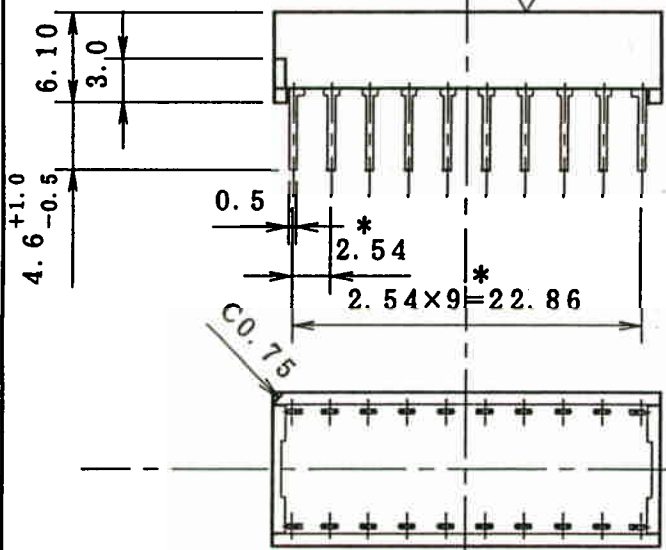

Pin No.	Function	Pin No.	Function
1	Anode 1	11	Cathode 10
2	Anode 2	12	Cathode 9
3	Anode 3	13	Cathode 8
4	Anode 4	14	Cathode 7
5	Anode 5	15	Cathode 6
6	Anode 6	16	Cathode 5
7	Anode 7	17	Cathode 4
8	Anode 8	18	Cathode 3
9	Anode 9	19	Cathode 2
10	Anode 10	20	Cathode 1

Notes:

1. Dimensional tolerance without any indication shall be ± 0.3
2. "*" Lead wire dimension. (The bottom of lead.)
3. It is out of spec for lead bending.
4. Soldering Recommendations: Max. 260°C, Less than 5 seconds.
5. Keep away at least 2 mm from resinous base of the lead.
6. Don't use freon solvent to wash.

SCALE: 2/1 THIRD ANGLE PROJECTION. ALL DIMENSIONS IN MILLIMETERS.

SEP. 25. 1998

Approved	Checked	Designed	DEVELOPMENT SPECIFICATION			
<i>K. S. Sarda</i>	<i>S. Takami</i>	<i>A. H. J. J. J.</i>	P/N: LNV810105A			
				8		5

MARKING STYLE

1. The contents of marking.



- ① The trademark of Panasonic.
- ② A customer part number.
- ③ The country of origin.
- ④ A manufacturing lot number.

2. The marking position.

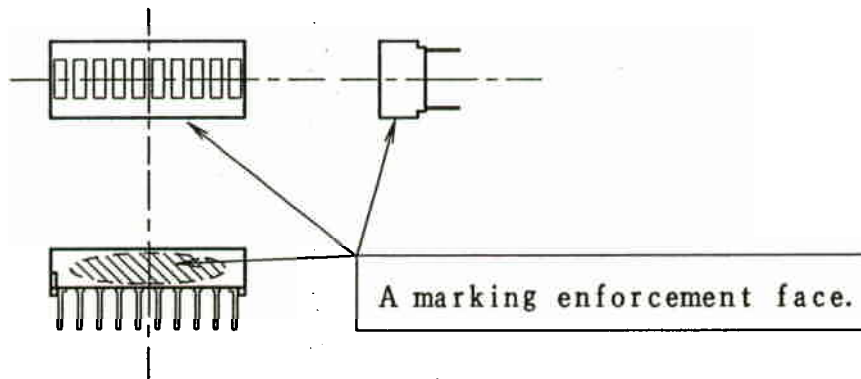

3. Color of ink.

BLACK

4. The standard that gives a manufacturing lot number.

< Example >

< Meaning >



Production : A. D. 1998, September

The month when this part was manufactured.
 JAN:1 , FEB:2 , MAR:3 , APR:4 , MAY:5 ,
 JUN:6 , JUL:7 , AUG:8 , SEP:9 , OCT:0 ,
 NOV:N , DEC:D

The year when this part was manufactured.
 1998 → 8

SEP. 25. 1998			
---------------	--	--	--

PACKING STYLE

※Line the products into a sheet with their direction corresponded with each other.

1. SHEET

(7 pcs × 5 lines = 35pcs)

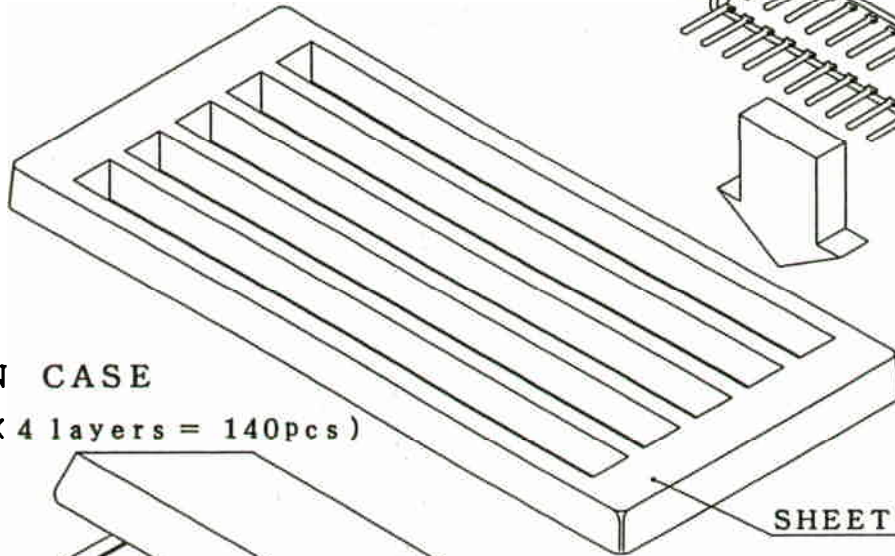
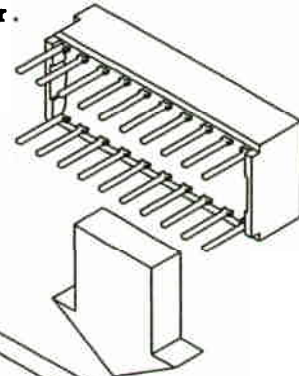

2. CARTON CASE

(35 pcs × 4 layers = 140pcs)

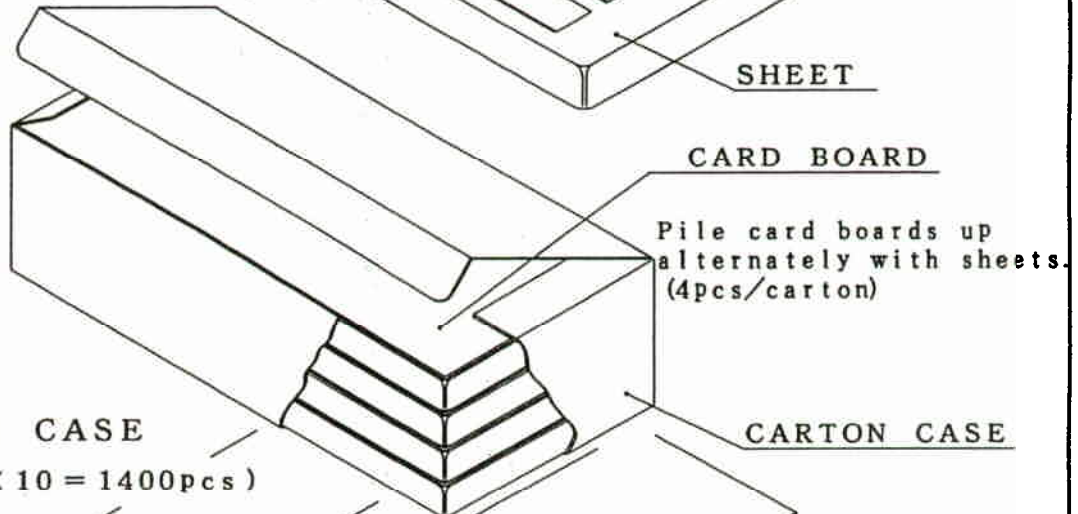

3. PACKING CASE

(140 pcs × 10 = 1400pcs)

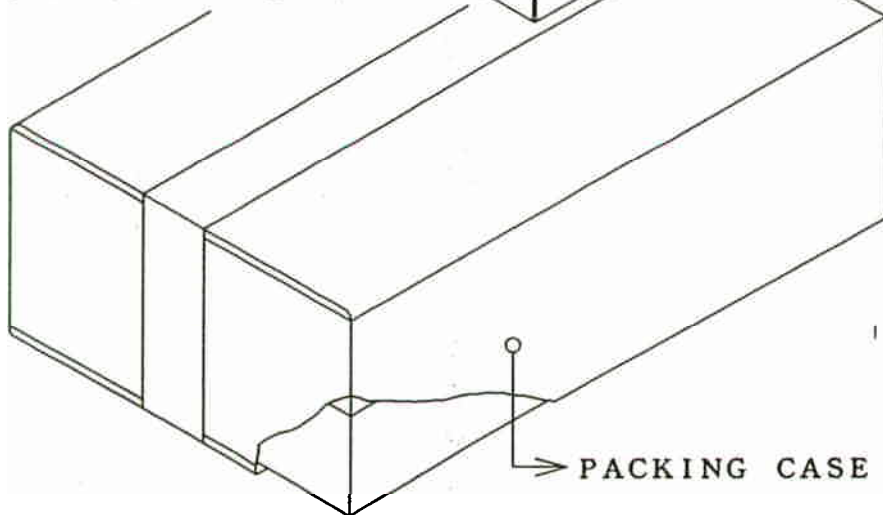

4. Number of components used for packing.

SHEET	1/35pcs	CARTON CASE	1/140pcs
CARD BOARD	1/35pcs	PACKING CASE	1/1400pcs

Approved	Checked	Designed
<i>K. Sameda</i>	<i>S. Takahashi</i>	<i>A. Nishiyama</i>

DEVELOPMENT SPECIFICATION

P/N: LNV810105A

8

7

Specification of contents entry to packing materials.

1. Contents that enter to a laber.

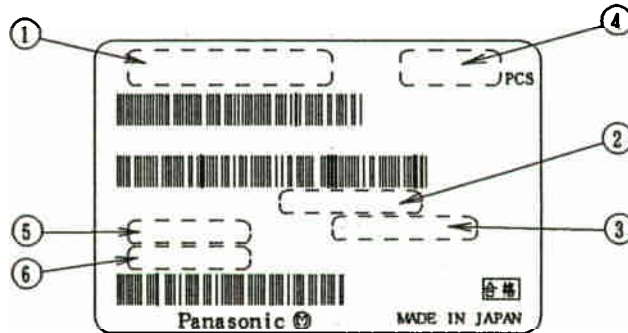

- ① — A customer number.
- ② — A maker part number.
- ③ — A maker part number.
- ④ — Packing quantity.
- ⑤ — A luminous intensity rank.
However, we do not carry out a luminous intensity rank.
- ⑥ — A manufacturing lot number.

3. Label position.

A label is attached to the position where it shows with a rough sketch.

< CARTON CASE >

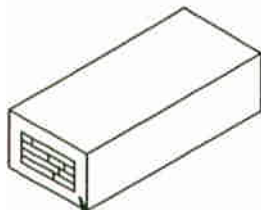

Label position.

< PACKING CASE >

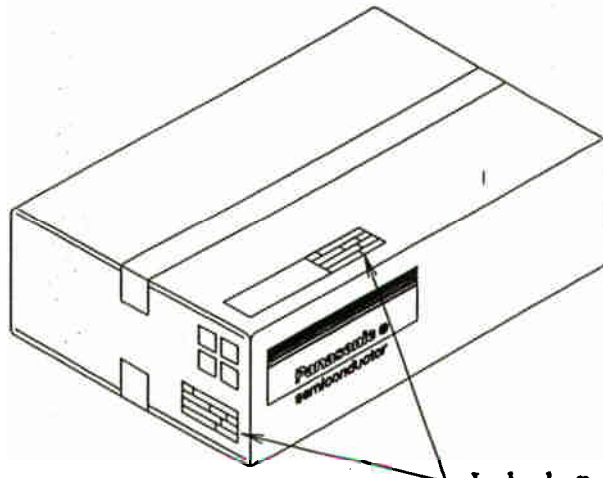

Label position.

Approved	Checked	Designed	DEVELOPMENT SPECIFICATION		
<i>K. Sameda</i>	<i>S. Takami</i>	<i>M. Niijawaki</i>	P/N: <u>LNV810105A</u>		
			8		8

Requests and Cautions for Use

1. An export permit needs to be obtained from the competent authorities of the Japanese Government if any of the products or technologies described in this document and controlled under the "Foreign Exchange and Foreign Trade Control Law" is to be exported or taken out of Japan.
2. The technical information described in this document is limited to showing representative characteristics and applied circuit examples of the products. It does not constitute the warranting of industrial property, the granting of relative rights, or the granting of any license.
3. The products described in this document are intended to be used for standard applications or general electronic equipment (such as office equipment, communications equipment, measuring instruments and household appliances).
 Consult our sales staff in advance for information on the following applications:
 - Special applications (such as for airplanes, aerospace, automobiles, traffic control equipment, combustion equipment, life support systems and safety devices) in which exceptional quality and reliability are required, or if the failure or malfunction of the products may directly jeopardize life or harm the human body.
 - Any applications other than the standard applications intended.
4. When designing your equipment, comply with the guaranteed values, in particular those of maximum rating, the range of operating power supply voltage and heat radiation characteristics. Otherwise, we will not be liable for any defect which may arise later in the equipment.
 Even when the products are used within the guaranteed values, redundant design is recommended, so that such equipment may not violate relevant laws or regulations because of the function of our products.
5. When using products for which vacuum packing is required, observe the conditions (including shelf life and after-unpacking stand-by time) agreed upon when specification sheets are individually exchanged.

SEP.25.1998			