

200 Watt - LD200W Series

CONSTANT VOLTAGE OR CONSTANT CURRENT LED DRIVER WITH DIMMING



200W
 LD200W Series
 DIMMING

Model: LD200W Series

- Drive Mode: Constant Current or Constant Voltage
- Technology: PFC Corrected 2-Stage Switch Mode
- Output Power: 200W Max.
- Input Voltage: 90 to 305VAC, 47- 63Hz
- Number of Outputs: One
- Output Voltages: 8VDC - 445VDC
- Output Currents: 450mA - 8330mA
- Optional 0-10V or PWM Positive Dimming 10% ~ 100%

Environmental

1. Operating temperature: Tc 90C Maximum. Reference -30 to +60°C ambient
2. UL Type TL (Tref Max/Meas. Tref): 90/82°C
3. Storage temperature range: -40 to +85°C
4. Humidity (non-condensing): 5% - 95%RH
5. Cooling: Convection
6. Vibration Frequency: 5-55Hz/2g, 30 minutes
7. Impact resistance: 1g/s
8. MTBF@ 40°C: 280,000 hours @ Full Load per MIL-217F Notice 2.

Safety and Compliance

1. UL8750, EN61347, CSA 22.2, UL Type TL & HL recognized.
2. FCC, 47CFR Part 15 Class B certified
3. Water resistant and Dust Proof Design: IP66, NEMA6, for Dry, Damp, Wet Locations.
4. Compact Miniature, Lightweight Design.
5. Safety Isolation between Primary and Secondary
6. Meets EN61000-3-2 & EN61000-3-3 Class C
7. Protection: output over-voltage, output over-current, output short circuit, auto-recovery.
8. EN61000-4-5: 2kV/4kV 8/20 µsec surge protection.

Electrical Specifications at 25°C

- Input voltage range: 90 to 305VAC
- Frequency: 47- 63HZ
- Power Factor: ≥ 0.90 at $\geq 60\%$ Load, 120Vac/230Vac/277Vac 50/60Hz
- THD%: $\leq 20\%$ at $\geq 60\%$ Load, 120Vac/230Vac/277Vac 50/60Hz
- Inrush current: $<60A$ at 25C, 277Vac, cold start, Full Load
- Input current: 0.96A Max @ 230Vac, 1.82A Max @ 120Vac, Full Load
- Efficiency: Up to 92% typical at 230Vac Full Load
- Line regulation accuracy: $\pm 3\%$
- Load regulation accuracy: $\pm 4\%$
- Leakage current: 600uA typical; Hold up time: half cycle

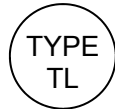

IP66



Constant Current Versions

Part Number ⁽²⁾	UL Types	Output Voltage Range	Output Constant Current	Current Accuracy	Output Power Maximum	Typical Efficiency ⁽¹⁾
LD200W-445-C0450	TL & HL	149 - 445 VDC	450 mA	$\pm 5\%$	200W	92%
LD200W-285-C0700	TL & HL	95 - 285 VDC	700 mA	$\pm 5\%$	200W	92%
LD200W-190-C1050	TL & HL	64 - 190 VDC	1050 mA	$\pm 5\%$	200W	91%
LD200W-142-C1400	TL & HL	48 - 142 VDC	1400 mA	$\pm 5\%$	200W	91%
LD200W-114-C1750	TL & HL	38 - 114 VDC	1750 mA	$\pm 5\%$	200W	91%
LD200W-95-C2100	TL & HL	32 - 95 VDC	2100 mA	$\pm 5\%$	200W	91%
LD200W-81-C2450	TL & HL	27 - 81 VDC	2450 mA	$\pm 5\%$	200W	90%
LD200W-71-C2800	TL & HL	24 - 71 VDC	2800 mA	$\pm 5\%$	200W	90%
LD200W-63-C3150	TL & HL	21 - 63 VDC	3150 mA	$\pm 5\%$	200W	90%
LD200W-57-C3500	TL & HL	19 - 57 VDC	3500 mA	$\pm 5\%$	200W	90%
LD200W-47-C4200	TL & HL	16 - 47 VDC	4200 mA	$\pm 5\%$	200W	89%
LD200W-40-C4900	TL & HL	14 - 40 VDC	4900 mA	$\pm 5\%$	200W	89%
LD200W-35-C5600	TL & HL	12 - 35 VDC	5600 mA	$\pm 5\%$	200W	89%
LD200W-32-C6300	TL & HL	11 - 32 VDC	6300 mA	$\pm 5\%$	200W	88%
LD200W-24-C8330 ⁽⁵⁾	TL & HL	8 - 24 VDC	8330 mA	$\pm 5\%$	200W	88%

Notes

1. Typical efficiency measured at 230VAC input, full load
2. For dimmable versions add appropriate designator to the end of the part number: For Example: LD200W-24-C8330-RD is 0-10V or resistance dimmable version, LD200W-24-C8330-PD is PWM dimmable version.
 -RD 0-10V & Resistance dimmable version comes with an extra two wires +Purple/-Grey on the output side.
 -PD PWM Dimmable version comes with an extra two wires +Purple/-Grey on the output side.
3. -RD 0-10V Dimming is compatible with most quality 0-10V wall dimmers and direct 0-10V analog signal. See page 3 for details.
4. -PD PWM version is PWM Dimmable via a positive 10% to 100% Duty Cycle, 500Hz to 1.5kHz, 0-10V Pulse. See page 4 for details.
5. SAM Recognized.

200 Watt - LD200W Series

CONSTANT VOLTAGE OR CONSTANT CURRENT LED DRIVER WITH DIMMING

Constant Voltage Versions

Part Number	UL Types	Output Constant Voltage	Output Current Range	Voltage Accuracy	Output Power Maximum	Typical Efficiency ⁽¹⁾
LD200W-445	TL & HL	445 VDC	113 - 450 mA	± 5%	200W	92%
LD200W-285	TL & HL	285 VDC	175 - 700 mA	± 5%	200W	92%
LD200W-190	TL & HL	190 VDC	263 - 1050 mA	± 5%	200W	91%
LD200W-142	TL & HL	142 VDC	350 - 1400 mA	± 5%	200W	91%
LD200W-114	TL & HL	114 VDC	438 - 1750 mA	± 5%	200W	91%
LD200W-95	TL & HL	95 VDC	525 - 2100 mA	± 5%	200W	91%
LD200W-81	TL & HL	81 VDC	613 - 2450 mA	± 5%	200W	90%
LD200W-71	TL & HL	71 VDC	700 - 2800 mA	± 5%	200W	90%
LD200W-63	TL & HL	63 VDC	788 - 3150 mA	± 5%	200W	90%
LD200W-57	TL & HL	57 VDC	875 - 3500 mA	± 5%	200W	90%
LD200W-47	TL & HL	47 VDC	1050 - 4200 mA	± 5%	200W	89%
LD200W-40	TL & HL	40 VDC	1225 - 4900 mA	± 5%	200W	89%
LD200W-35	TL & HL	35 VDC	1400 - 5600 mA	± 5%	200W	89%
LD200W-32	TL & HL	32 VDC	1575 - 6300 mA	± 5%	200W	88%
LD200W-24 ⁽⁵⁾	TL & HL	24 VDC	2083 - 8330 mA	± 5%	200W	88%

Mechanical Dimensions: Inches [mm]

Material: Black Aluminum Housing
Fully Encapsulated
Weight: 940 grams (33.2 oz) Typical

Labeling Example

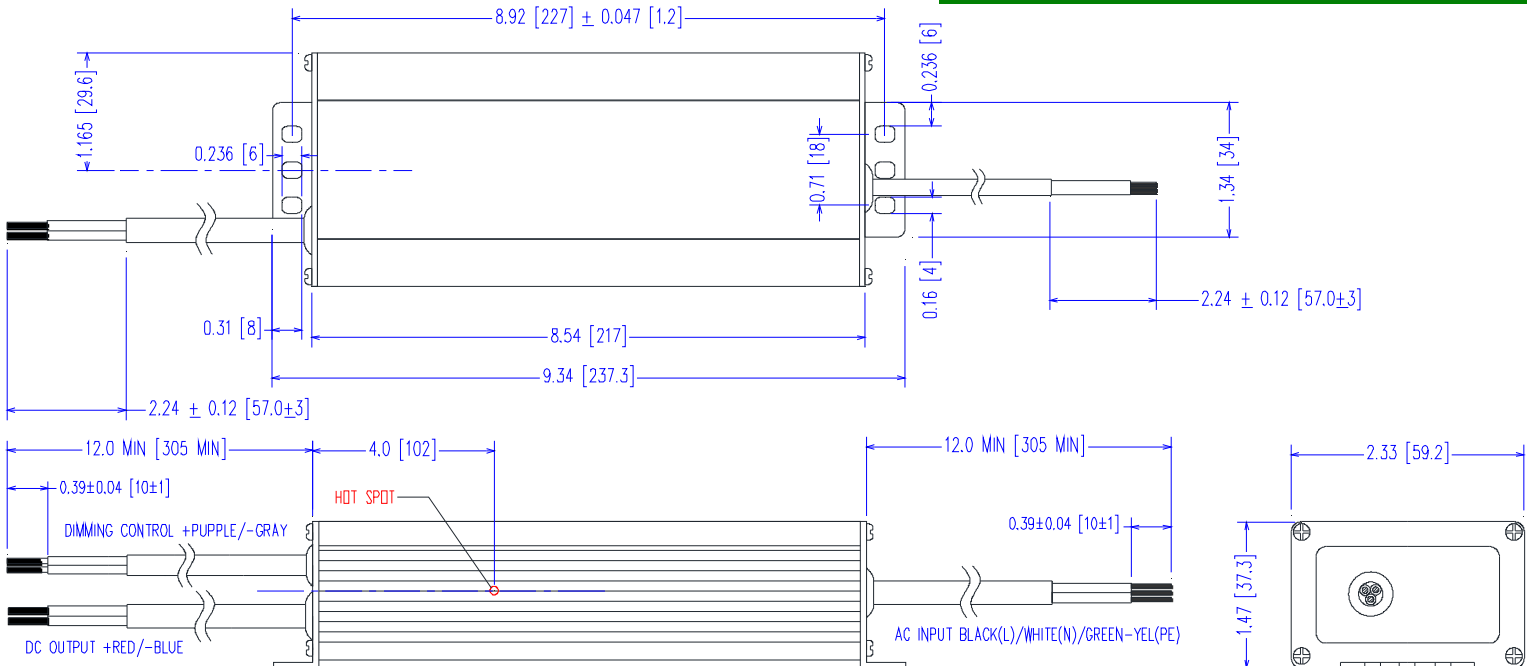
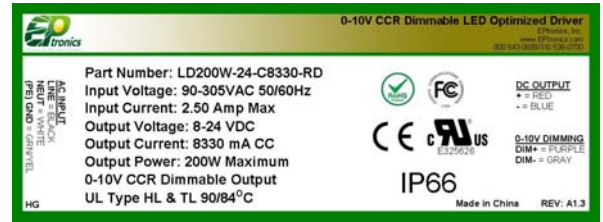

200 Watt - LD200W Series

CONSTANT VOLTAGE OR CONSTANT CURRENT LED DRIVER WITH DIMMING

200W
 LD200W Series
 DIMMING

-RD 2-Wire 0-10V CCR Dimming Scheme

Parameters	Minimum	Typical	Maximum
Source Current out of 0-10V Purple Wire	0mA	—	2mA
Absolute Voltage Range on 0-10V (+) Purple Wire	-2.0V	—	+15V
Sink Current into 0-10V Purple Wire	0mA	—	1.2mA

Notes

1. -RD 0-10V dimmable version comes with an extra two wires +Purple/-Grey on the output side.
2. -RD version is compatible with most 0-10V Wall Slide dimmers and direct 0-10V analog signal.
Recommended wall slide dimmer is Leviton IP710 or equivalent
3. -RD 0-10V dimmable version is not intended to dim below about 5% @ 0V or 10% @ 1.0V
4. -RD 0-10V dimmable version output will be 100% with Purple/Grey open and minimum with Purple/Grey Shorted.

-RD 2-Wire Resistance Dimming Scheme

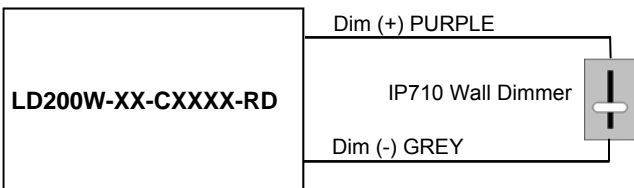

-RD 2-Wire 0-10V Analog Dimming Scheme

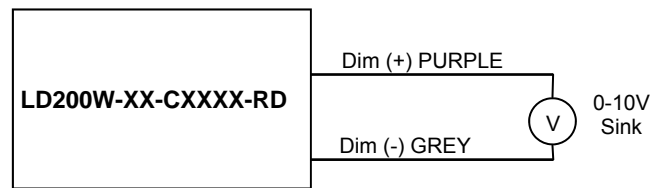

% Output Current vs. 0-10VDC Dimming Input

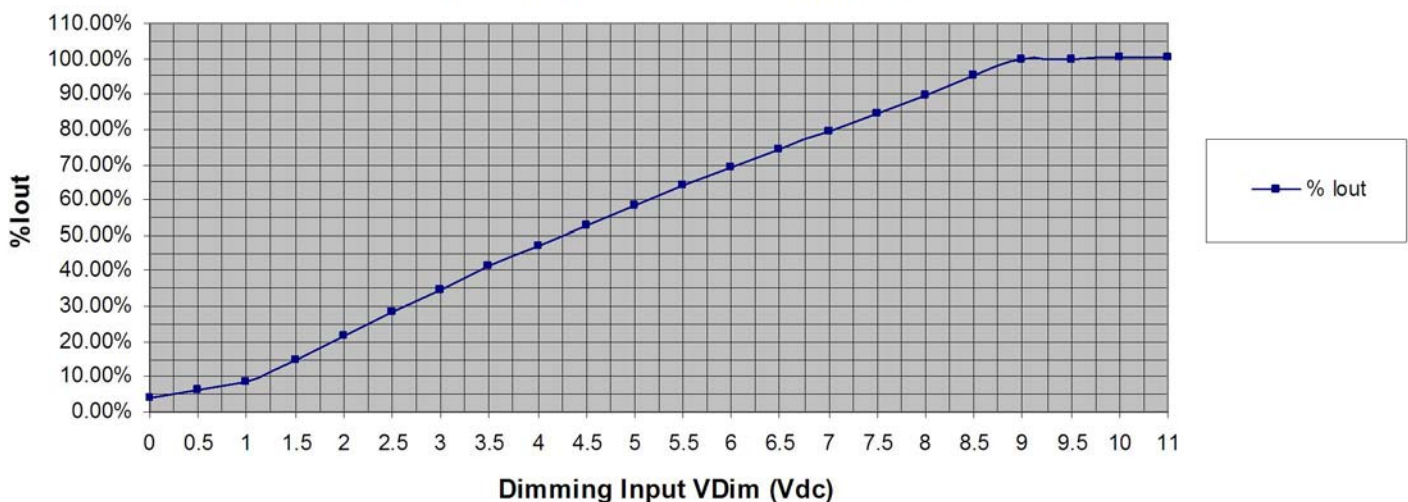

200 Watt - LD200W Series

CONSTANT VOLTAGE OR CONSTANT CURRENT LED DRIVER WITH DIMMING

-PD 2-Wire CCR PWM Positive Dimming Scheme

Parameters	Minimum	Typical	Maximum
Absolute Maximum Voltage Range on PWM Input (Purple Wire)	-2.0V	10V	+15V
Input LOW Level Voltage Range (Purple Wire)	-2.0V	0V	+5.5V
Input HIGH Level Voltage Range (Purple Wire)	+9.0V	10V	+15V
Current into PWM Input (Purple Wire)	0mA	—	1.2mA
Source Current out of PWM Input (Purple Wire)	0mA	—	2mA
PWM Input Signal Frequency	500Hz	—	1500Hz
PWM Input Signal Positive Duty Cycle	0%	10-90%	100%

Notes

1. -PD PWM Dimmable version comes with an extra 2 wires +Purple/-Grey on the output side.
2. -PD PWM Dimmable version is not intended to dim below about 5% @ 0% Duty Cycle or 10% @ 10% Duty Cycle
3. -PD PWM dimmable version output will be 100% with Purple/Grey open and minimum with Purple/Grey Shorted.

-PD 2-Wire PWM Positive Dimming Scheme

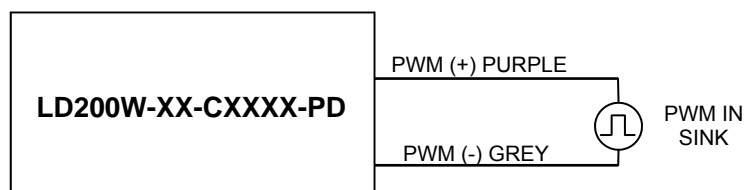

% Output Current vs. 1.0 kHz, Positive Duty Cycle Dimming Input

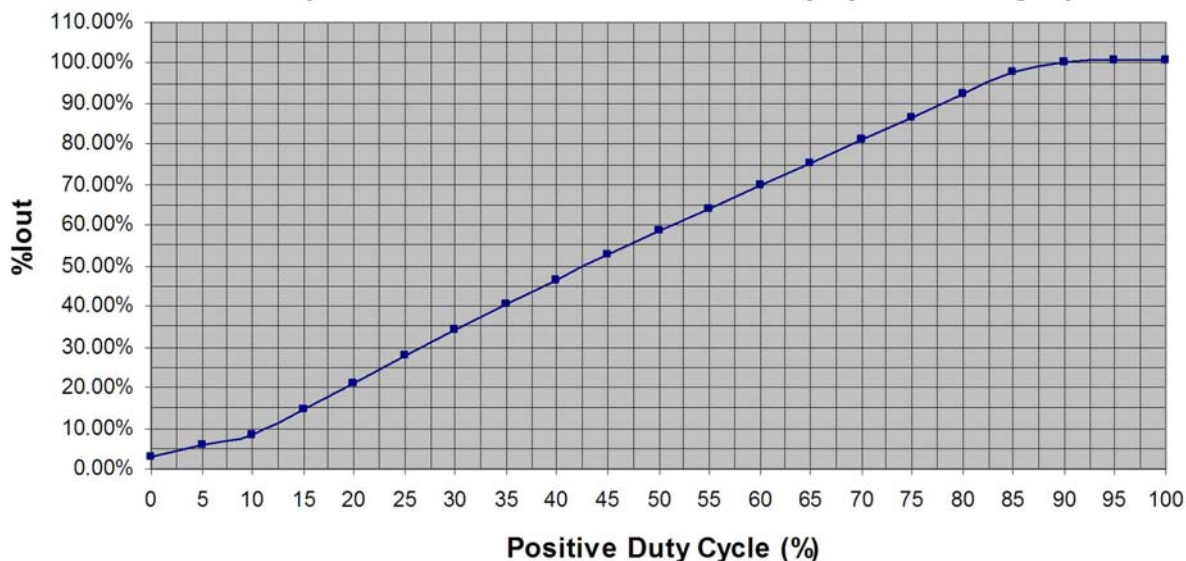

200 Watt - LD200W Series

CONSTANT VOLTAGE OR CONSTANT CURRENT LED DRIVER WITH DIMMING

200W
 LD200W Series
 DIMMING

Input Specifications

Parameter	Min.	Typ.	Max.	Notes/Conditions
Input Voltage	90 Vac	—	305 Vac	120, 230, 240, 277 Vac Nominal Values
Input Frequency	47 Hz	—	63 Hz	50/60Hz Nominal
Input AC Current	—	—	1.82 A	Measured at 120Vac/60Hz Input, Output Full load.
	—	—	0.96 A	Measured at 230Vac/60Hz Input, Output Full load.
Inrush Current (Peak)	—	—	60A	Measured at 277Vac/60Hz Input, Output Full Load, Ta 25°C, Cold Start 50% I _{peak} duration \approx 750 μ sec ($1/2 \cdot I_p^2 \cdot t$)
Inrush Current (I ² t)	—	—	1.35 A ² s	
Leakage Current	—	—	0.68mA	Measured at 120Vac/60Hz Input, Output Full load.
	—	—	0.75mA	Measured at 277Vac/60Hz Input, Output Full load.
THD	—	—	20%	Measured at 120, 230, 277Vac Input, Output \geq 60% Load, See Graphs
Power Factor (PF)	0.90	—	—	Measured at 120, 230, 277Vac Input, Output \geq 60% Load, See Graphs

Output Specifications

Parameter	Min.	Typ.	Max.	Notes/Conditions
DC Output Voltage	Per Table	—	Per Table	Per Tables on Page 1
DC Output Constant Current	-5%	Per Table	+5%	Per Tables on Page 1
Output Power	—	—	Per Table	Per Tables on Page 1
Ripple & Noise (V _{pk-pk})	—	—	5% V _o	20 MHz BW, Full load output in parallel with 0.1 μ F ceramic & 10 μ F Electrolytic. 120 Hz component (Flicker Free)
Ripple (I _{pk-pk})	—	—	5% I _o	20 MHz BW, Full load output in parallel with 0.1 μ F ceramic & 10 μ F Electrolytic. 120 Hz component (Flicker Free)
Start-up Time	—	150 mS	1000 mS	Measured at 120Vac/60Hz Input, Output Full load.
Hold-up Time	—	30 mS	—	Typical @ 277Vac Input, Output Full load.

Environmental Specifications

Parameter	Min.	Typ.	Max.	Notes/Conditions
Case Temperature (T _c)	-30 °C	—	+90 °C	Measured at location specified on case.
Operating Temperature (T _a)	-30 °C	—	+60 °C	This is a reference range. T _c controls temperature range.
Storage Temperature (T _s)	-40 °C	—	+85 °C	Non operating temperature range.
Operating Humidity	—	—	95% RH	Relative Humidity, non-condensing.
Vibration	5 Hz	—	55 Hz	2G, 10 minutes/1 cycle, period 30 minutes, each along X, Y, Z axis.
MTBF	280,000 Hours	—	—	MIL-HDBK-217F Notice 2, T _a = 40C, Output Full Load.

Protection Specifications

Parameter	Min.	Typ.	Max.	Notes/Conditions
Output Short Circuit (SCP)	—	—	—	No Damage, Auto recovery after short is removed.
Output Over Current (OCP)	—	—	+10% I _o	Constant Current Limiting circuit.
Output Over Voltage (OVP)	—	—	120% V _o	No Damage, Auto recovery after fault is removed.

200 Watt - LD200W Series

CONSTANT VOLTAGE OR CONSTANT CURRENT LED DRIVER WITH DIMMING

Safety Certification

Safety	Notes/Standards
UL/CUL	UL8750, UL1310 for UL Class 2 & CAN/CSA C22.2 No. 250.13, UL Type HL & TL 90/84 °C
CE	EN61347-1, EN61347-2-13
Withstand Voltage	Input to Output: 3750 Vac. Parts use a GDT. Hipot cannot be done with Case or GND connected.
Isolation Resistance	Input to Output: >100 MΩ, 500VDC @ 25 °C, 70 % RH
Dimming Circuit	Dim+ Purple/Dim- Grey are considered part of the secondary circuit.

EMC Certification

Standard	Notes/Conditions
FCC, 47CFR Part 15	Class B
EN 55015	Limits and methods of measurement of radio disturbance characteristics of electrical lighting and similar equipment.
EN 61000-3-2	Part 3-2: Limits for harmonic current emissions Class C, ≥80% Rated Power
EN 61000-3-3	Part 3-3: Limitation of voltage changes, voltage fluctuations and flicker.
EN 61000-4-5	Part 4-5: Surge Immunity test, 2 kV L-N, 4 kV L-FG & N-FG
Energy Star	Energy Star transient protection: Ballast or driver shall comply with ANSI/IEEE C62.41.1-2002 and ANSI/IEEE C62.41.2-2002, Category A operation. The line transient shall consist of seven strikes of a 100 kHz ring wave, 2.5 kV level, for both common mode and differential mode.

Power Factor Curves (Typical)

PF vs. Output Power

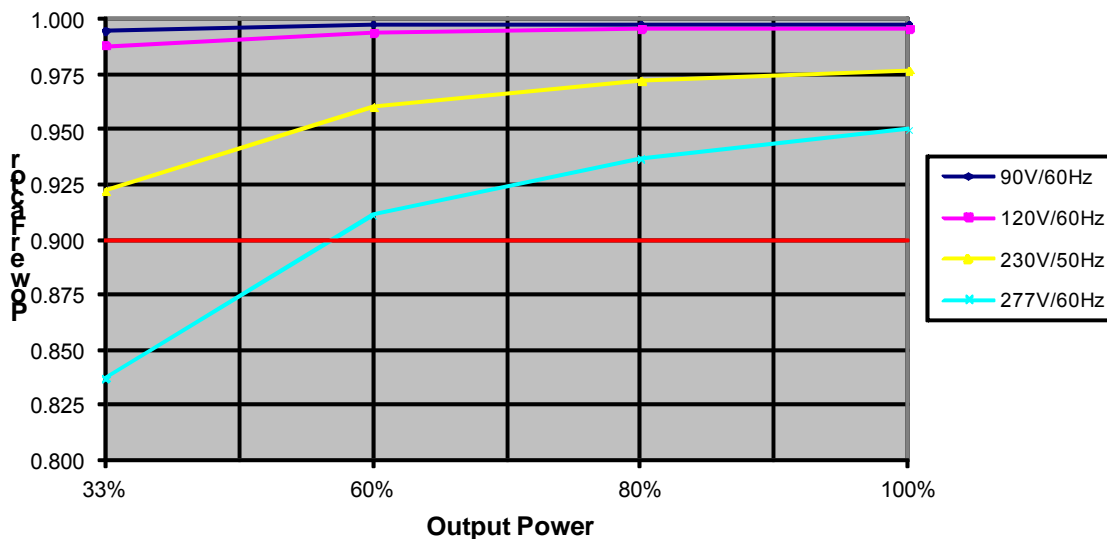

200 Watt - LD200W Series

CONSTANT VOLTAGE OR CONSTANT CURRENT LED DRIVER WITH DIMMING

200W
 LD200W Series
 DIMMING

THD Curves (Typical)

THD vs. Output Power

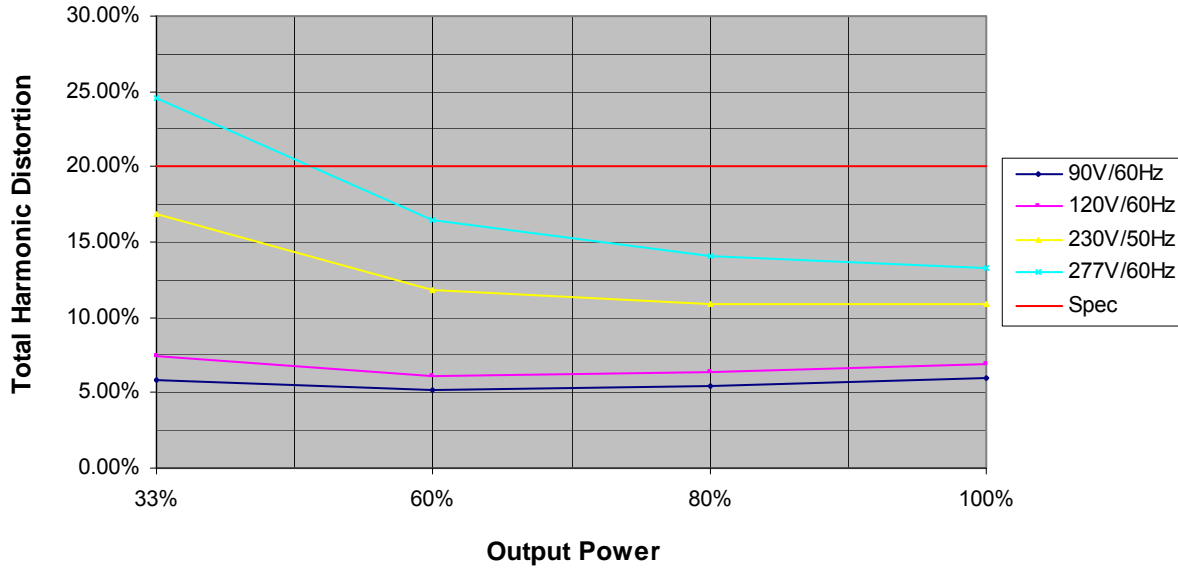

Efficiency Curve (Typical) LD200W-445-C0450-RD

Efficiency vs. Output Power

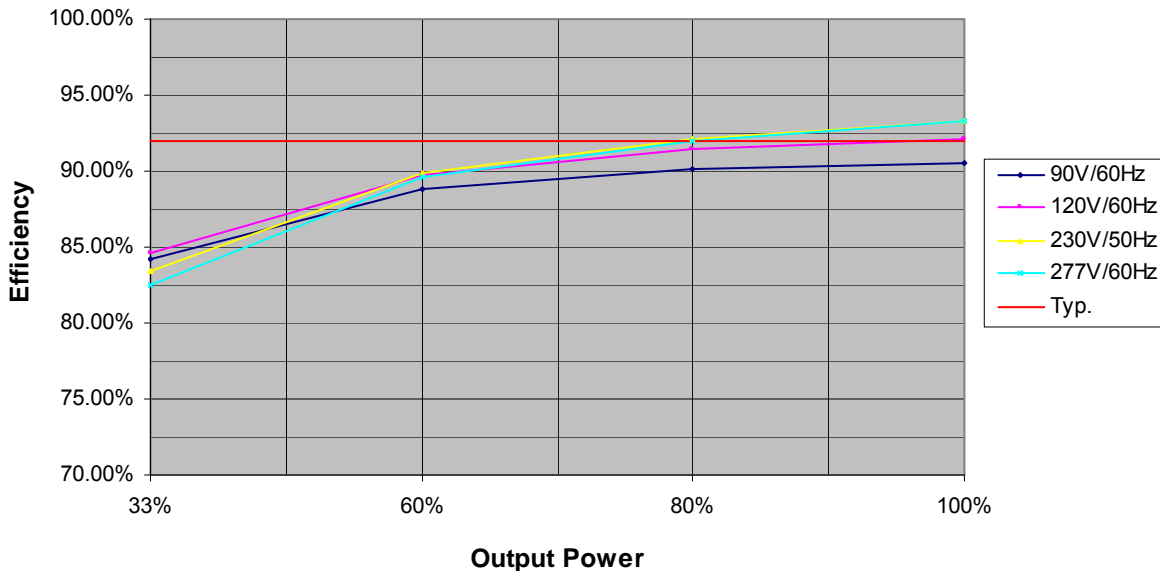

200 Watt - LD200W Series

CONSTANT VOLTAGE OR CONSTANT CURRENT LED DRIVER WITH DIMMING

Life vs. Ambient Temperature

LD200W Estimated Life Full Load @ 120Vac

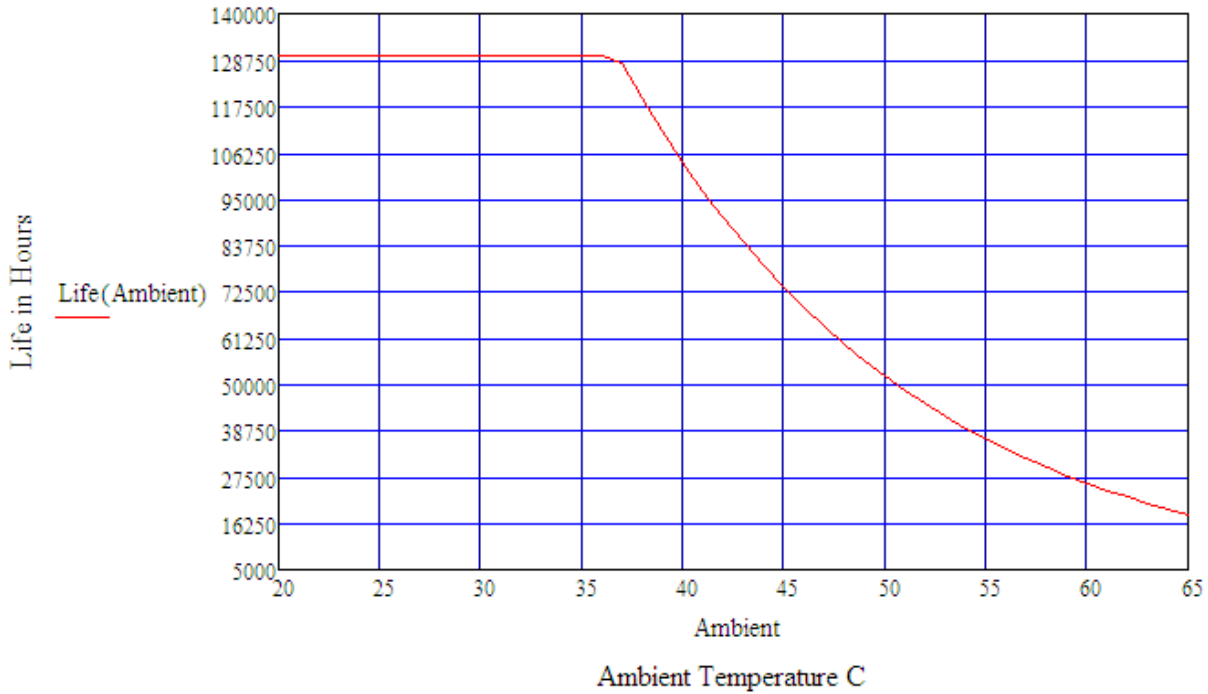

Life vs. Case (Tc) Temperature

LD200W Estimated Life Full Load @ 120Vac

