

- 1
- 2
- 3
- 4
- 5
- 6
- 7
- 8
- 9
- 10
- 11
- 12
- 13
- 14
- 15
- 16
- 17
- 18

LEVER BODY

Glass-fibre reinforced polyamide based (PA) technopolymer, black colour, glossy finish.

LEVER ARM

Matte chrome-plated steel with cylindrical handle 1.280 (see page 648) in Duroplast.

SELF-ADHESIVE FRONT PLATE

Matte anodised aluminium to be fitted after the assembly of the lever.

STANDARD EXECUTIONS

- **LBR-A:** black-oxide steel boss, H7 reamed hole.
 - **LBR-N:** without boss, with plain hole and flat face.
- LBR.45 N and LBR.54 N: flat face opposite to the arm.
LBR.75 N: flat face in correspondance of the arm.

MANOEUVRE ANGLE LIMITATION

A limited manoeuvre angle is possible by fitting stop pins in the rear guide slot.

ACCESSORIES ON REQUEST

- Axial retaining washer GN 184 (see page 1021).
- Ball and spring for clicking operation to be fitted into the two holes d3 drilled at 180° (see ball and spring MS. on page 713).

SPECIAL EXECUTIONS ON REQUEST

- Different arm lengths and handle shapes.
- Front plate with words, marks, symbols, graphics.



ELESA Original design **if79**

Assembly examples

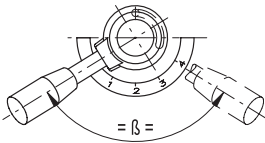

Assembly by means of angle limit stop pins

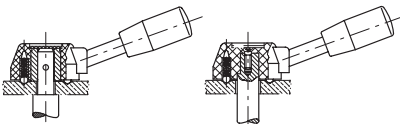

Assembly by means of ball and spring for clicking operation

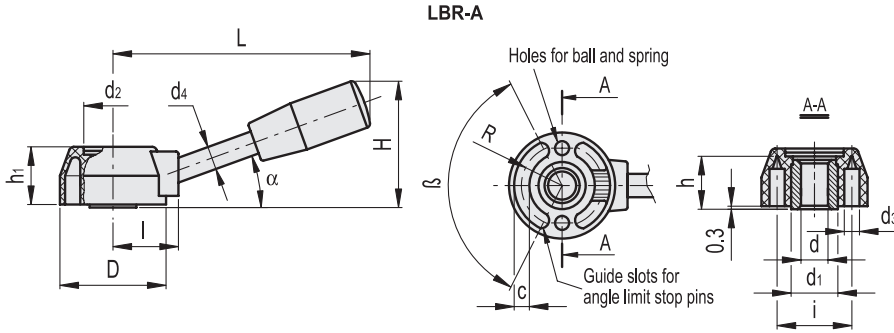

LBR-A

METRIC

Code	Description	D	dH7	L	H	h	h1	d1	d2	d3*	d4	i	l	R	c	α	β	⚖
33101	LBR.37/85 A-8	37	8	81	46	17	20	18	21	5	10	26	22	13.8	4.3	25°	125±1°	75
33102	LBR.37/85 A-10	37	10	81	46	17	20	18	21	5	10	26	22	13.8	4.3	25°	125±1°	71
33103	LBR.37/85 A-12	37	12	81	46	17	20	18	21	5	10	26	22	13.8	4.3	25°	125±1°	66
33201	LBR.45/110 A-8	45	8	108	52	22	25	22	25	6	10	32	28	17.5	7	20°	125±1°	132
33202	LBR.45/110 A-12	45	12	108	52	22	25	22	25	6	10	32	28	17.5	7	20°	125±1°	120
33203	LBR.45/110 A-15	45	15	108	52	22	25	22	25	6	10	32	28	17.5	7	20°	125±1°	105
33301	LBR.54/130 A-10	54	10	127	61	27	30	26	31	8	12	39	34	20.2	7.3	20°	125±1°	213
33302	LBR.54/130 A-14	54	14	127	61	27	30	26	31	8	12	39	34	20.2	7.3	20°	125±1°	198
33303	LBR.54/130 A-18	54	18	127	61	27	30	26	31	8	12	39	34	20.2	7.3	20°	125±1°	175
33401	LBR.75/170 A-18	75	18	170	80	34	38	30	42	10	14	55	45	26	15	20°	105±1°	360

* Ball diameter

Conversion Table	
1 mm = 0.039 inch	
D	
mm	inch
37	1.46
45	1.77
54	2.13
75	2.95

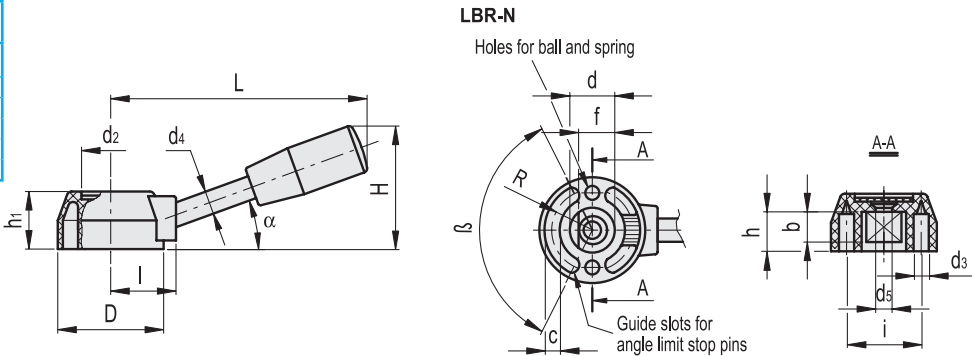

LBR-N

METRIC

Code	Description	D	dH8	L	H	h	h1	d2	d3*	d4	d5	i	l	R	c	α	β	f+0.05	b	⚖
33211	LBR.45/110 N-16	45	16	108	52	16	25	25	6	10	6.5	32	28	17.5	7	20°	125±1°	13	12	80
33311	LBR.54/130 N-22	54	22	125	66	21	30	31	8	12	6.5	39	34	20.2	7.3	25°	125±1°	19	16	130
33411	LBR.75/170 N-25	75	25	170	80	26	38	42	10	14	8.5	55	45	26	15	20°	105±1°	22	21	255

* Ball diameter