



TAOGLAS®



Datasheet

2.4GHz Embedded Loop Chip Antenna

Part No:
LA.02

Description

1dBi 2400MHz to 2500MHz Wi-Fi/Bluetooth/Bluetooth LE/ ZigBee

Features:

8*2*2mm Ceramic Antenna

Surface Mount

Low Profile

Peak gain 1.9dBi

50 Ohm Impedance

Components can be mounted on opposite side of board to the antenna

RoHS & REACH Compliant

1.	Introduction	2
2.	Specification	4
3.	Antenna Characteristics	5
4.	Radiation Patterns	8
5.	Mechanical Drawing	12
6.	Packaging	13
7.	Antenna Integration Guide	15
8.	Solder Reflow Profile	21
<hr/>		
	Changelog	23

Taoglas makes no warranties based on the accuracy or completeness of the contents of this document and reserves the right to make changes to specifications and product descriptions at any time without notice. Taoglas reserves all rights to this document and the information contained herein. Reproduction, use or disclosure to third parties without express permission is strictly prohibited.



1. Introduction



The LA.02 is a 2.4GHz embedded loop chip antenna that has best in class efficiency, 70% on center frequency. It's a miniature SMD ceramic component, designed to be mounted directly on the edge of the main device PCB and is suitable especially for very small space requirements for Bluetooth LE, Wi-Fi, 802.11 applications. The LA.02 uses this main PCB ground plane to increase antenna efficiency, requiring minimum ground-clearance around the antenna. The opposite side of the board on which the antenna is mounted does not need ground-clearance, allowing more space for components or signal routing. This antenna is delivered on tape and reel.

Some frequency offset may happen as is normal with antennas embedded devices, so the antenna can be tuned for different PCB sizes and enclosures by simply changing the value of the matching circuit. Please contact your regional Taoglas sales office for support.

Many module manufacturers specify peak gain limits for any antennas that are to be connected to that module. Those peak gain limits are based on free-space conditions. In practice, the peak gain of an antenna tested in free-space can degrade by at least 1 or 2dBi when put inside a device. So ideally you should go for a slightly higher peak gain antenna than mentioned on the module specification to compensate for this effect, giving you better performance.

Upon testing of any of our antennas with your device and a selection of appropriate layout, integration technique, or cable, Taoglas can make sure any of our antennas' peak gain will be below the peak gain limits. Taoglas can then issue a specification and/or report for the selected antenna in your device that will clearly show it complying with the peak gain limits, so you can be assured you are meeting regulatory requirements for that module.

For example, a module manufacturer may state that the antenna must have less than 2dBi peak gain, but you don't need to select an embedded antenna that has a peak gain of less than 2dBi in free-space. This will give you a less optimized solution. It is better to go for a slightly higher free-space peak gain of 3dBi or more if available. Once that antenna gets integrated into your device, performance will degrade below this 2dBi peak gain due to the effects of GND plane, surrounding components, and device housing. If you want to be absolutely sure, contact Taoglas and we will test. Choosing a Taoglas antenna with a higher peak gain than what is specified by the module manufacturer and enlisting our help will ensure you are getting the best performance possible without exceeding the peak gain limits.

This antenna can be mounted with no performance degradation in either orientation as long as the antenna is soldered correctly via Surface mounting. Please see the integration instructions section for further detail regarding the optimum way to integrate this antenna into your device.

For further optimization to customer-specific device environments and for support to integrate and test this antennas performance in your device, contact your regional Taoglas Customer Services Team.

Applications:

Telematics devices

Bluetooth LE Wearables

Bluetooth Headsets

Hand-held devices when Bluetooth/Wi-Fi functions are needed, e.g., smart phone.

IEEE802.11 b/g

ZigBee

Wireless PCMCIA cards or USB dongle

2. Specification

Electrical								
Band	Frequency (MHz)	Efficiency (%)	Average Gain (dB)	Peak Gain (dBi)	Impedance	Polarization	Radiation Pattern	Max. input power
Wi-Fi - 2GHz	2400-2500	58.9	-2.30	1.78	50 Ω	Linear	Omni	2W

Mechanical	
Dimensions (mm)	8.0 x 2.0 x 2.0
Material	Ceramic
Weight (g)	0.11

Environmental	
Temperature Range	-40°C to 85°C
Storage Temperature	-40°C to 105°C
Temperature Coefficient (τf)	0 ± 20 ppm @-20°C to +80°C
Recommended Reel Storage Condition	5°C to 40°C Relative Humidity 20% to 70%
Moisture Sensitivity Level	3 (168 Hours)

3. Antenna Characteristics

3.1 Test Setup

AUT



Vector Network Analyzer

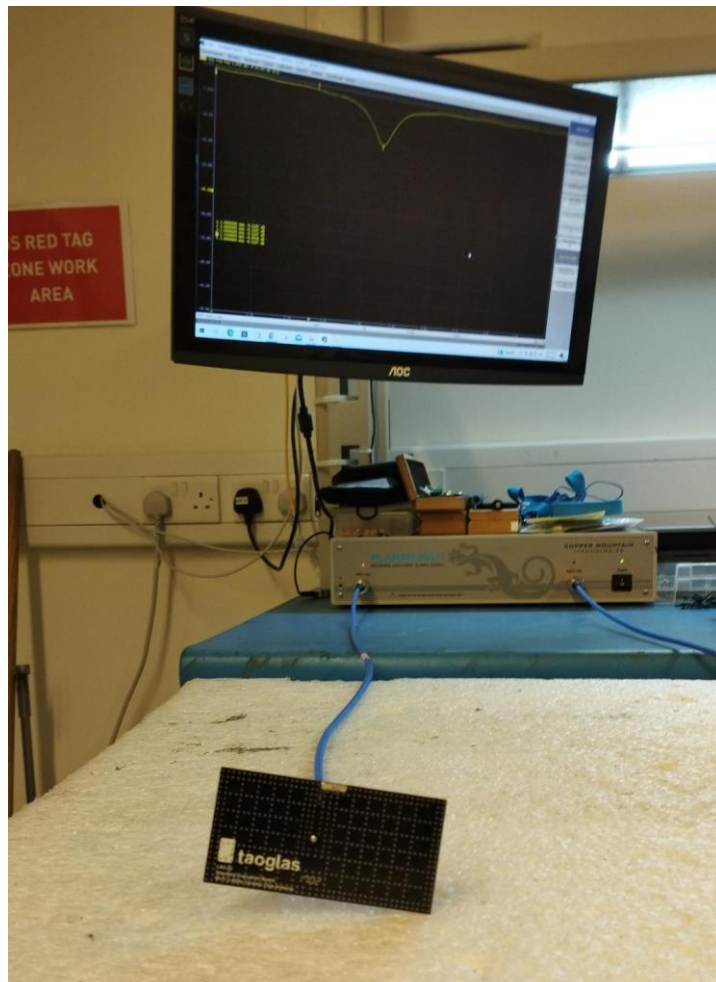

3.2 Return Loss

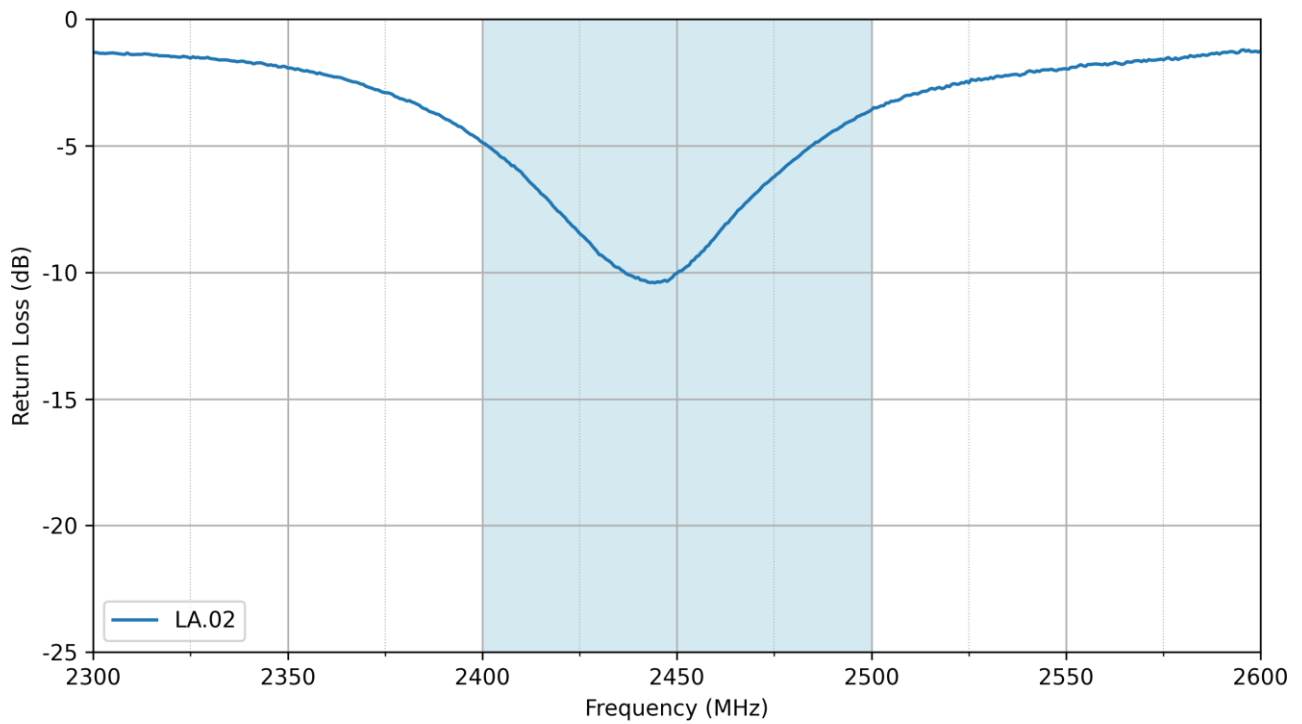

3.3 Efficiency

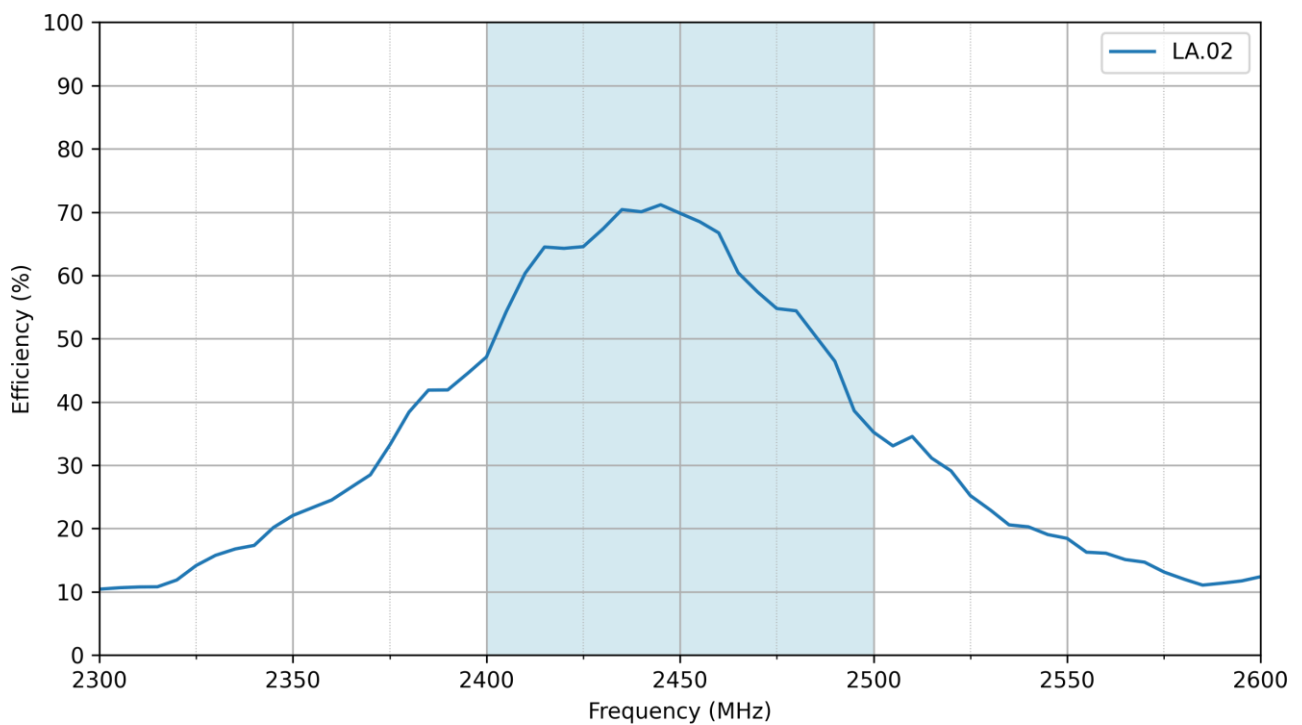

3.4 Average Gain

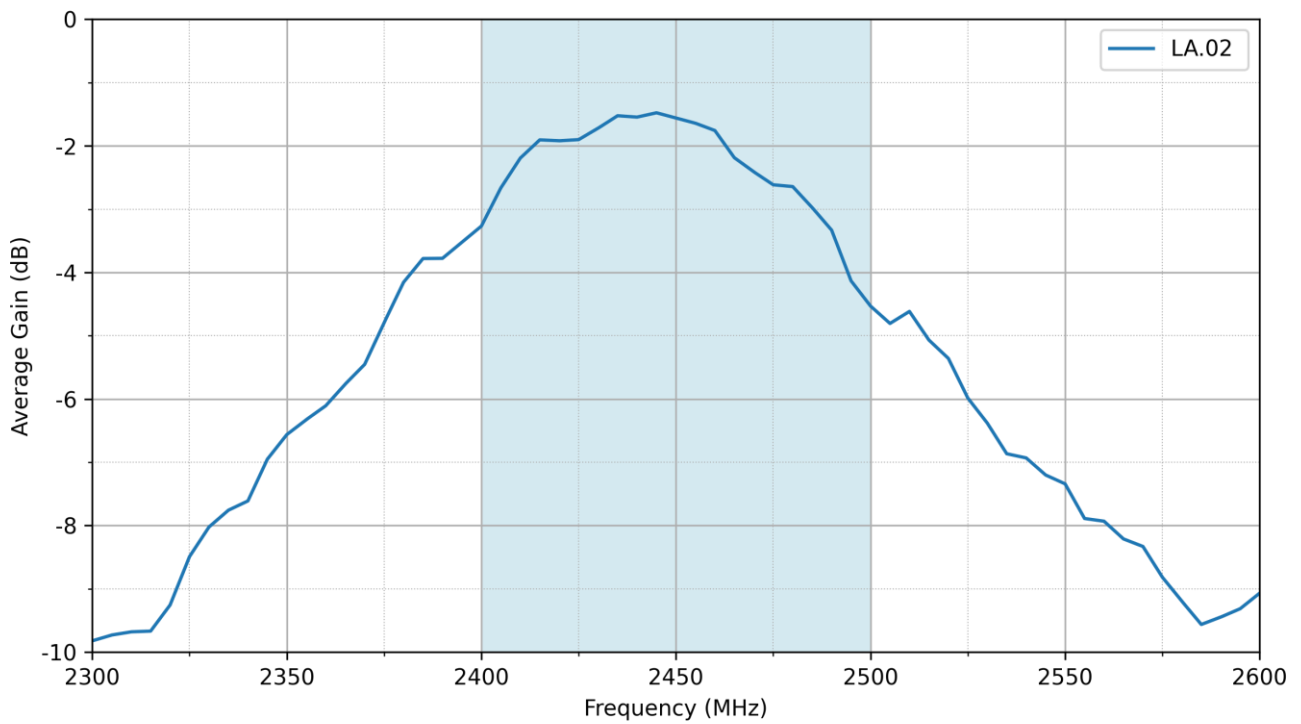

3.5 Peak Gain

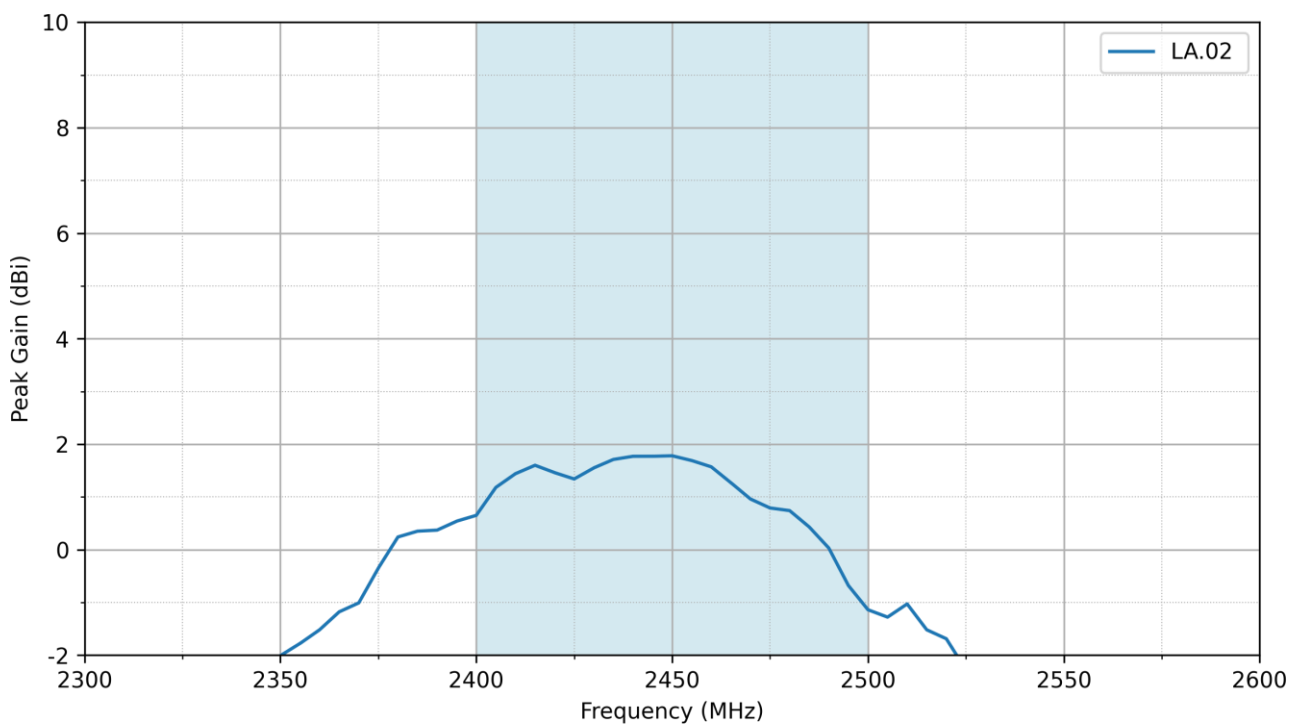

4. Radiation Patterns

4.1 Test Setup

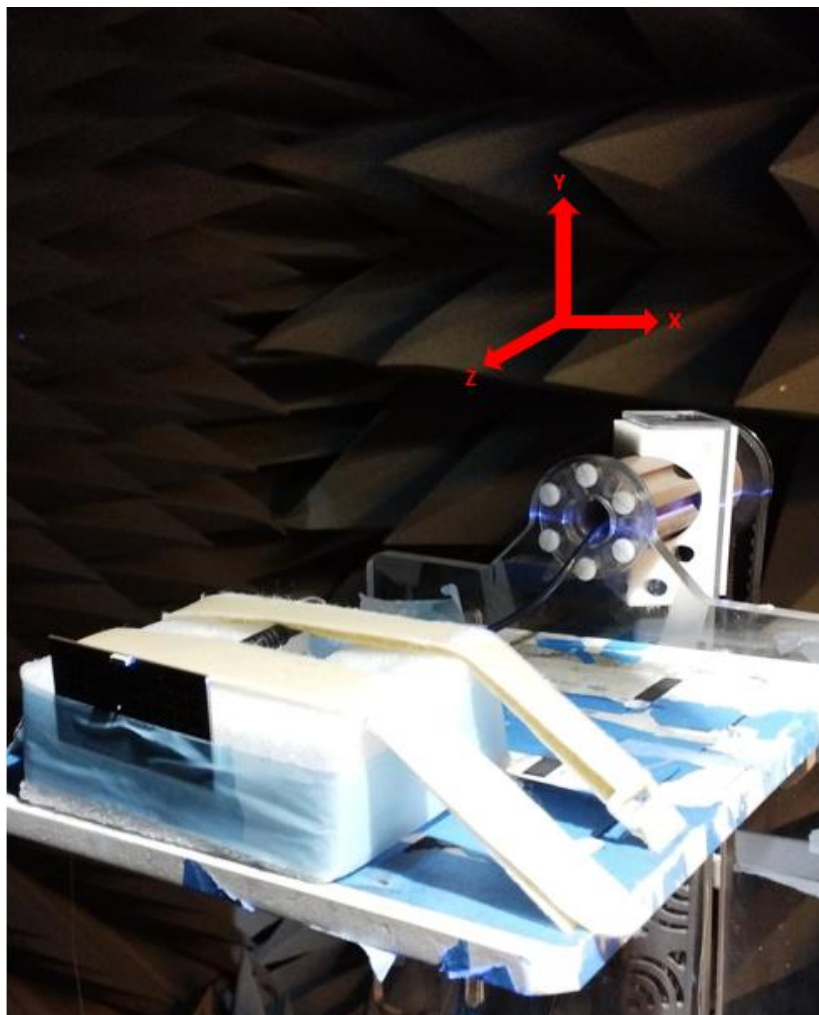
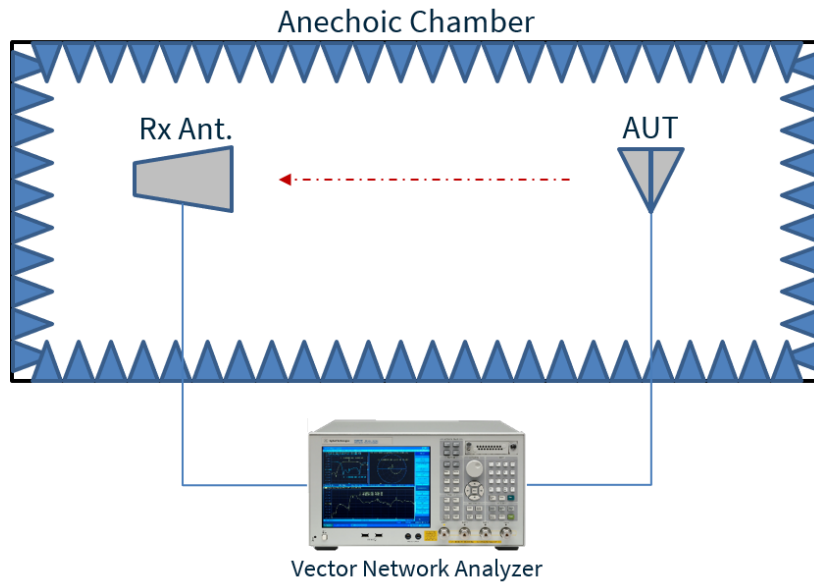

4.2 LA.02 Patterns at 2400 MHz

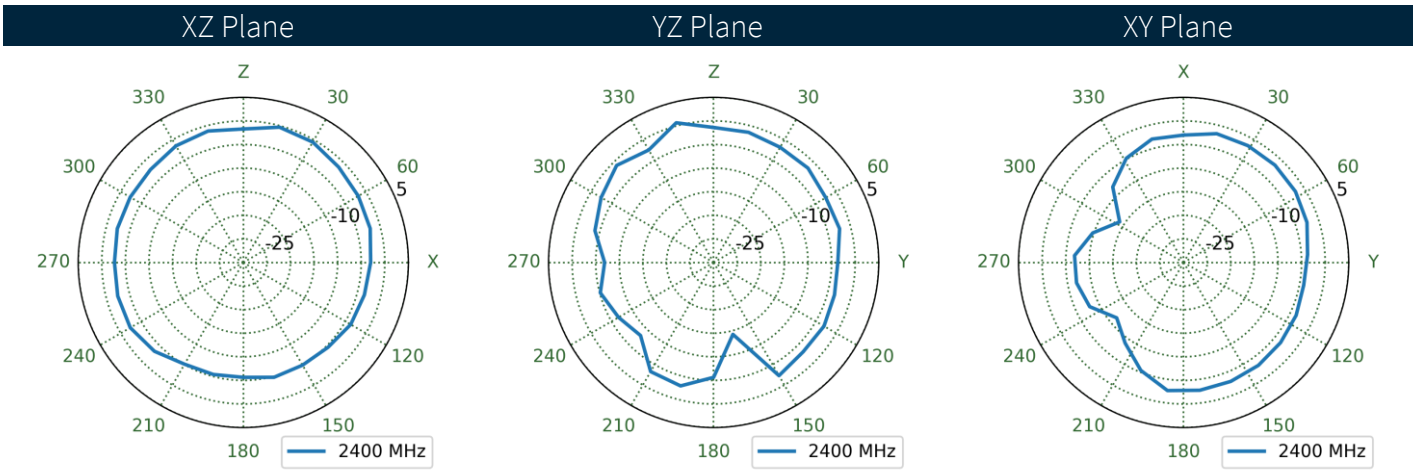
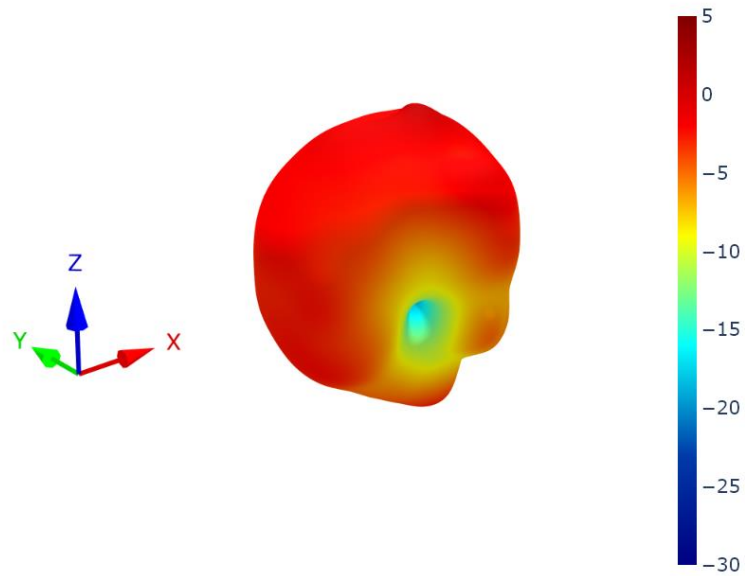

4.3 LA.02 Patterns at 2450 MHz

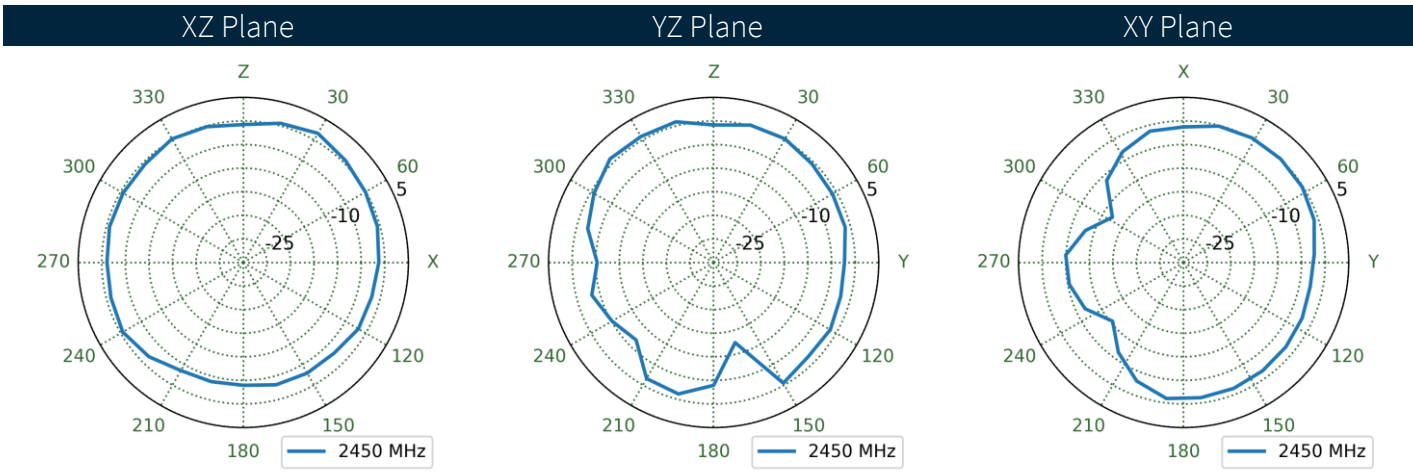
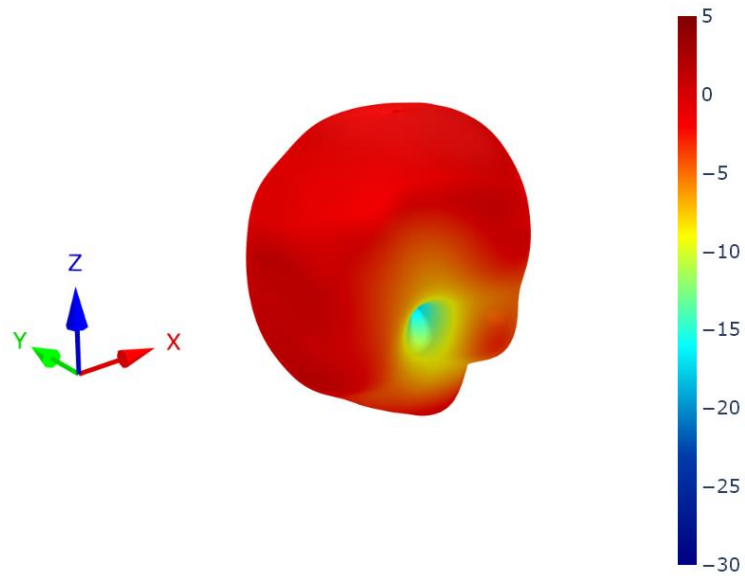

4.4 LA.02 Patterns at 2500 MHz

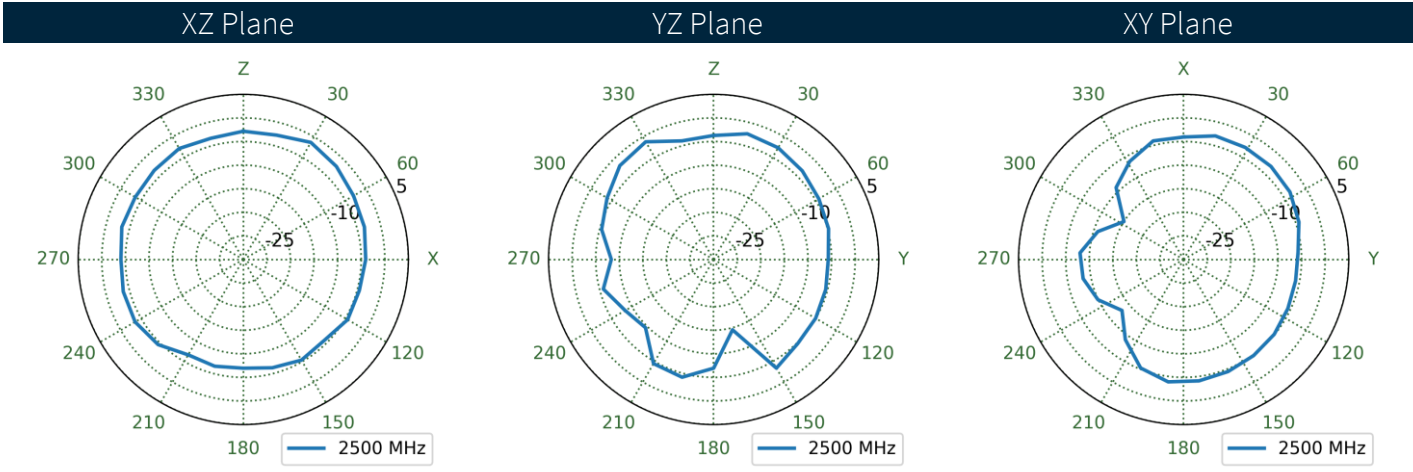
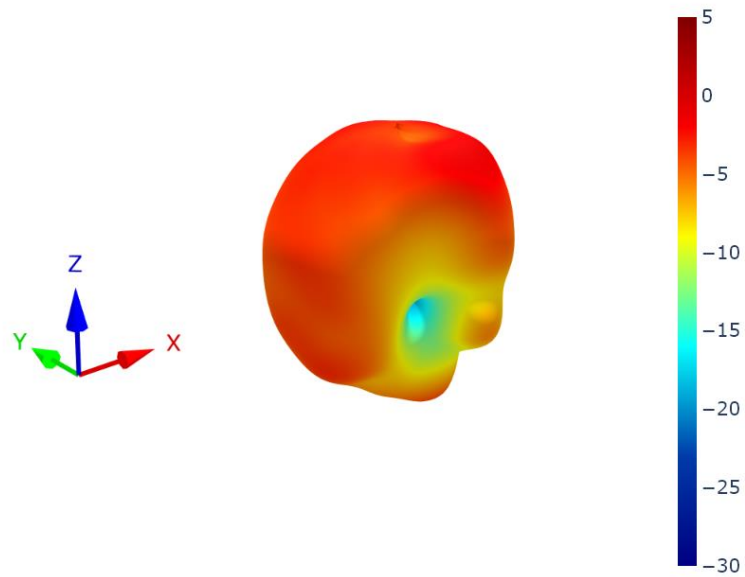

5. Mechanical Drawing

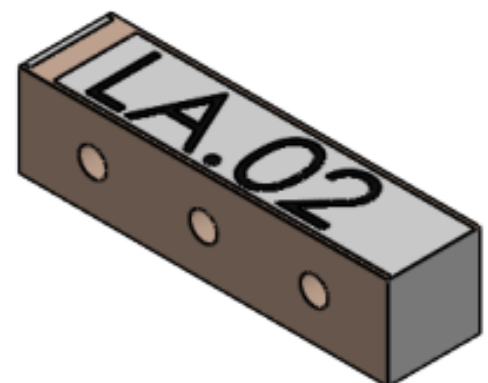
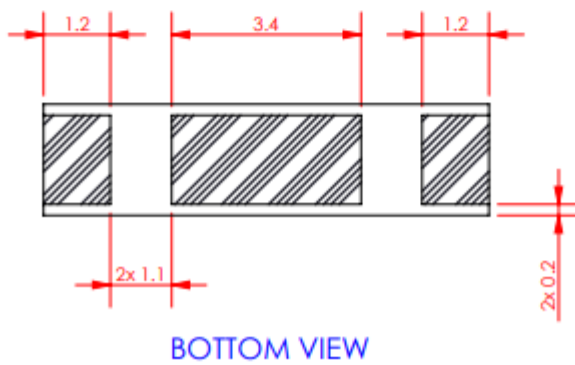
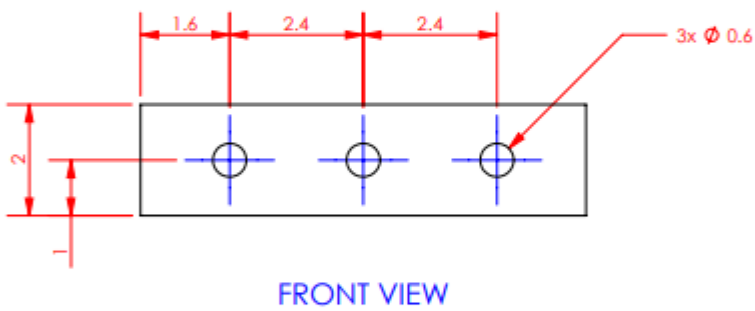
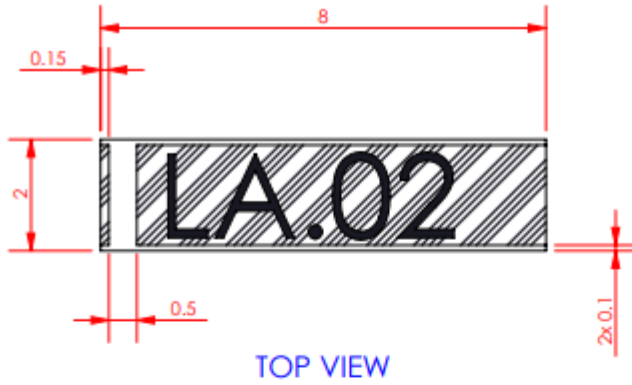

1 pc reel in small inner box
 Dimensions - 350*340*47mm
 Weight - 1Kg

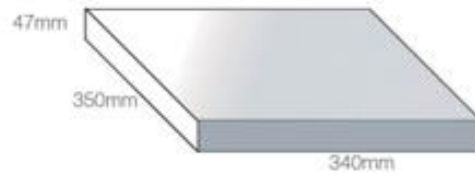

5 Reels / 10,000 pcs in one carton
 Carton Dimensions - 360*370*275mm
 Weight - 6Kg

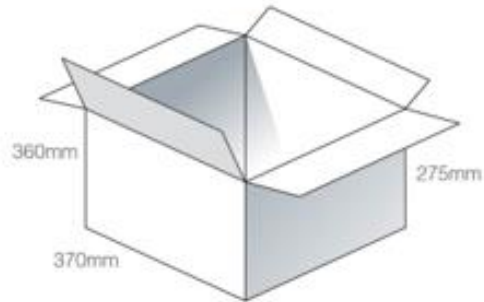

Pallet Dimensions 1100*1100*1550mm
 45 Cartons per Pallet
 9 Cartons per layer
 5 Layers

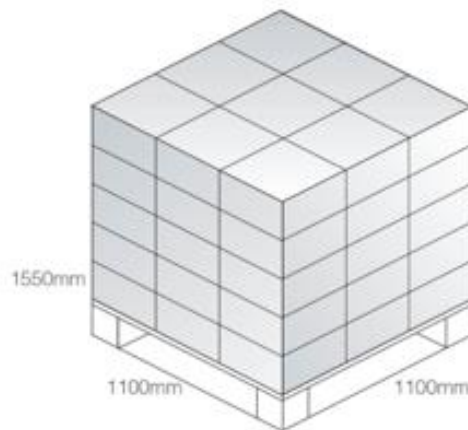

7. Antenna Integration Guide



7.1 Schematic and Symbol Definition

The circuit symbol for the antenna is shown below. The antenna has 4 pins with all pins as functional.

Pin	Description
1	RF Feed
2	FTE (Fine Tuning Element)
3, 4	Ground

TAOGLAS_LA.02
ANT1

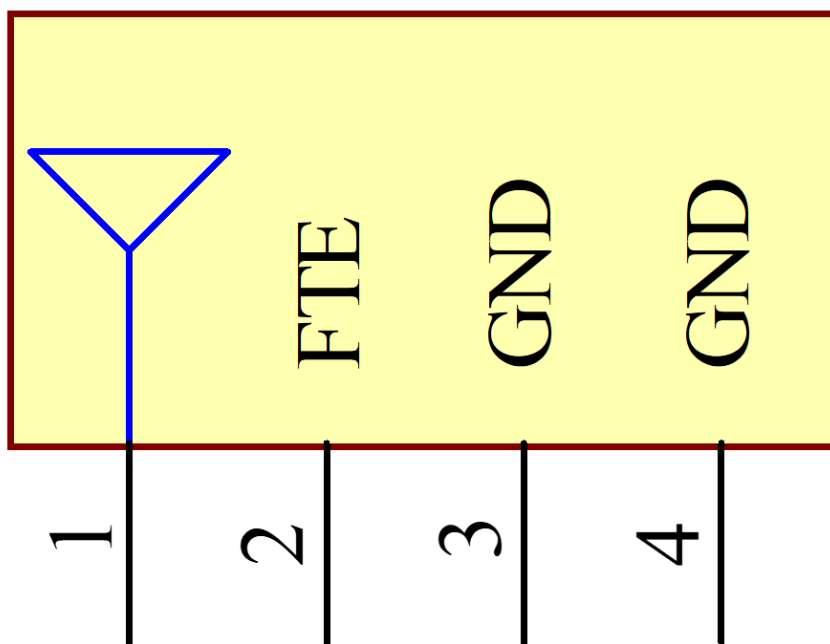

7.2 Antenna Integration

For any given PCB size, the antenna should ideally be placed on the PCB's longest side, to take advantage of the ground plane. Optimized matching components can be placed as shown.

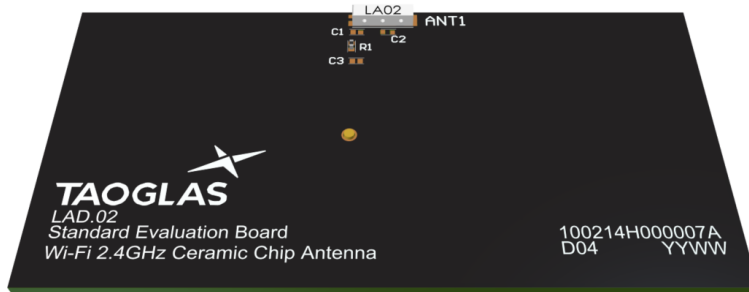

With Solder Mask

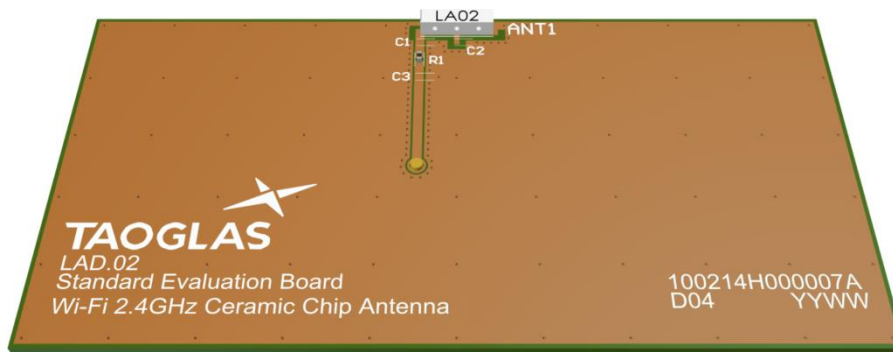

Without Solder Mask

7.3 PCB Clearance

Below shows the antenna footprint and clearance through ALL layers on the PCB. Only the antenna pads and connections to feed and GND are present within this clearance area (marked RED). The clearance area extends to 10.6mm in width and 2.8mm in length from the midpoint of the topside edge of the PCB. This clearance area only includes the topside layer.

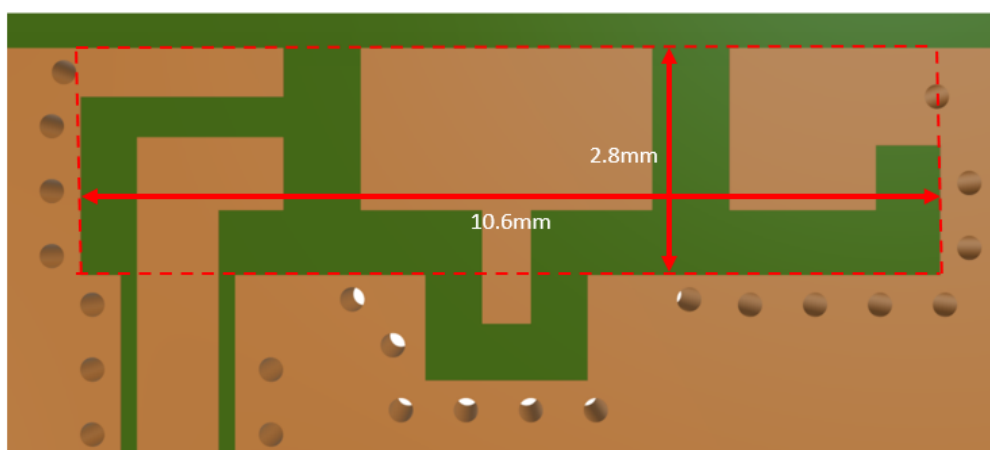

7.4 Evaluation Board

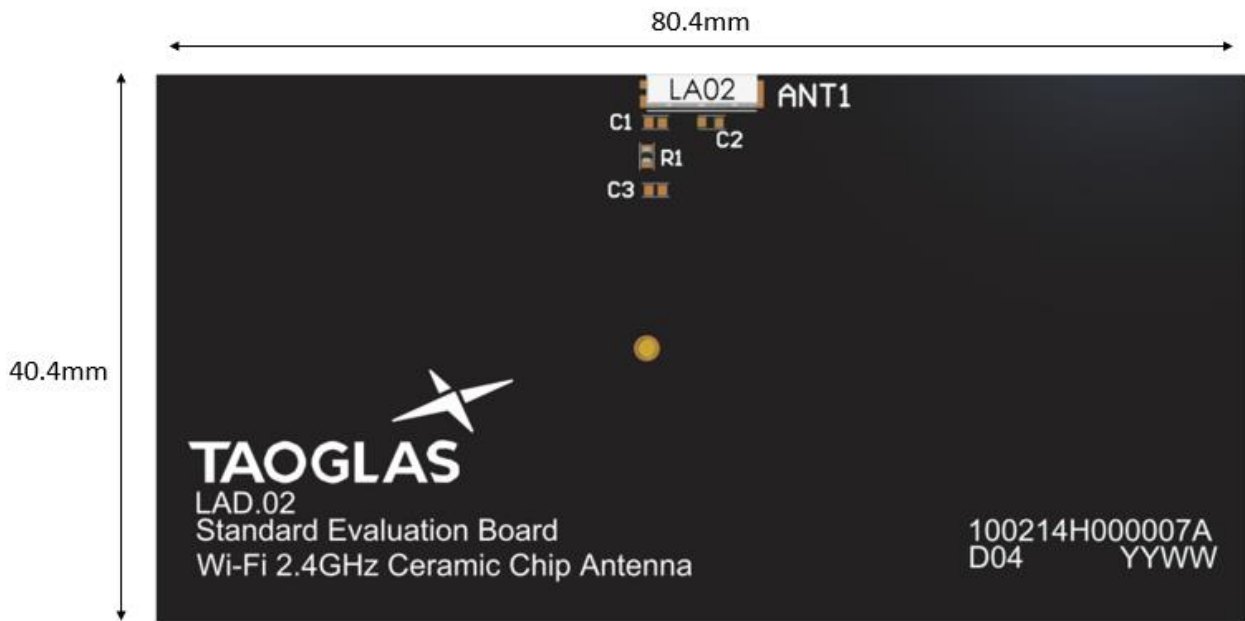

7.5 Evaluation Board Matching Circuit

Matching Components with the LA.02 are recommended for the antenna to have optimal performance on the evaluation board, located in the spaces specified in previous sections. Additional matching components may be necessary for your device, so we recommend incorporating extra component footprints, forming a “pi” network, between the cellular module and the edge of the ground plane.

Designator	Type	Value	Manufacturer	Manufacturer Part Number
R1	Resistor	0 Ohms	YAGEO	RC0402JR-070RL
C1, C2, C3	Capacitor	Not Fitted	-	-

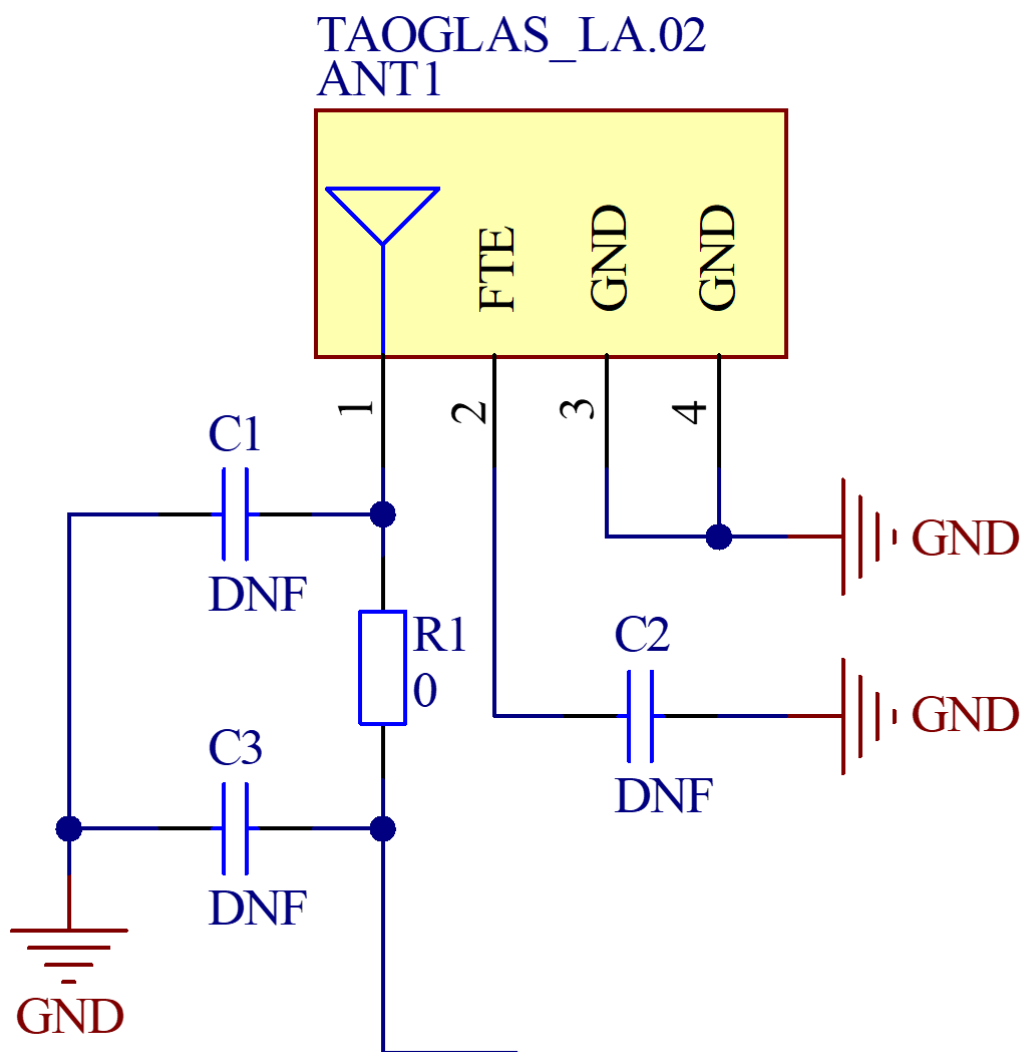

7.6 Footprint

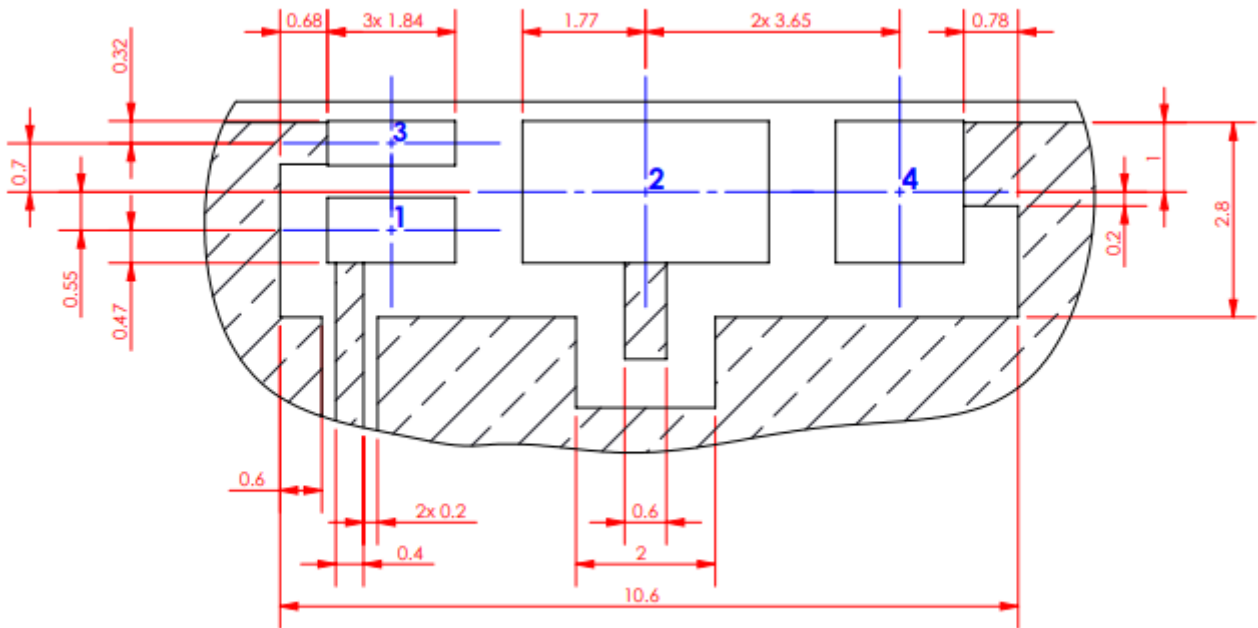

FOOTPRINT PCB

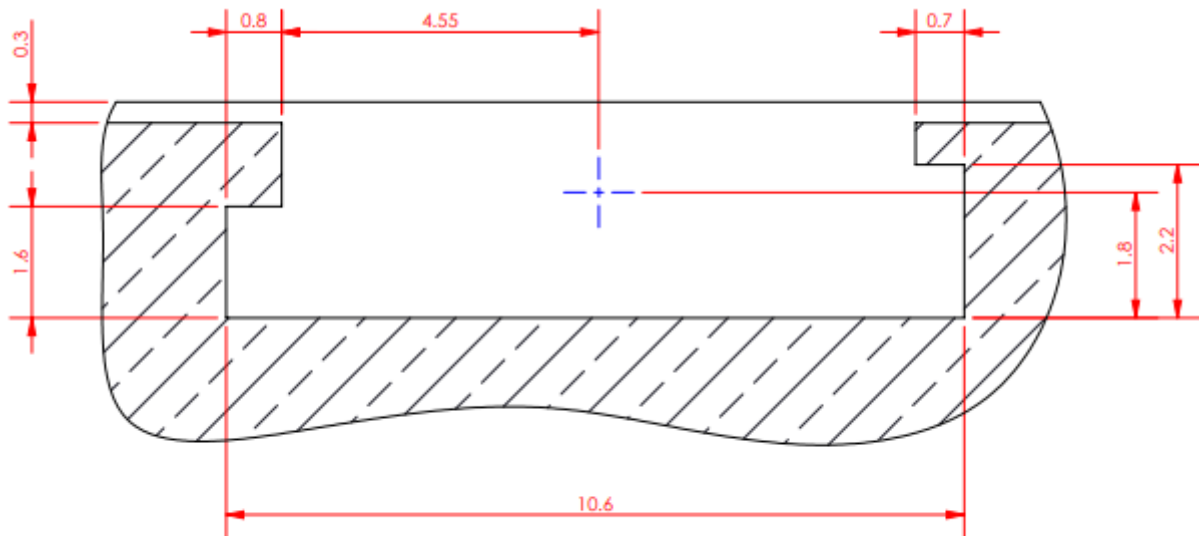

GROUND CLEARANCE BOTTOM VIEW

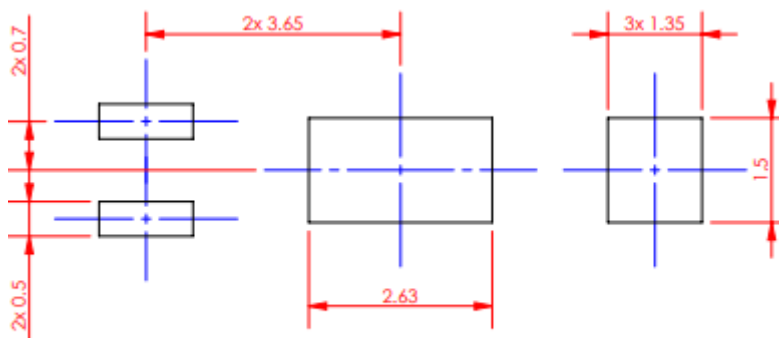

SOLDER PASTE

8. Solder Reflow Profile

Phase	Profile features	Pb-Free Assembly (SnAgCu)
PREHEAT	-Temperature Min(T_{smin}) -Temperature Max(T_{smax}) -Time(t_s) from (T_{smin} to T_{smax})	150°C 200°C 60-120 seconds
RAMP-UP	Avg. Ramp-up Rate (T_{smax} to TP)	3°C/second(max)
REFLOW	-Temperature(T_L) -Total Time above T_L (t_L)	217°C 30-100 seconds
PEAK	-Temperature(T_P) -Time(t_p)	260°C 5-10 second
RAMP-DOWN	Rate	6°C / second max.
Time from 25°C to Peak Temperature		8 minutes max.
Composition of solder paste		96.5Sn/3Ag/0.5Cu
Solder Paste Model		SHENMAO PF606-P26

The graphic shows temperature profile for component assembly process in reflow ovens

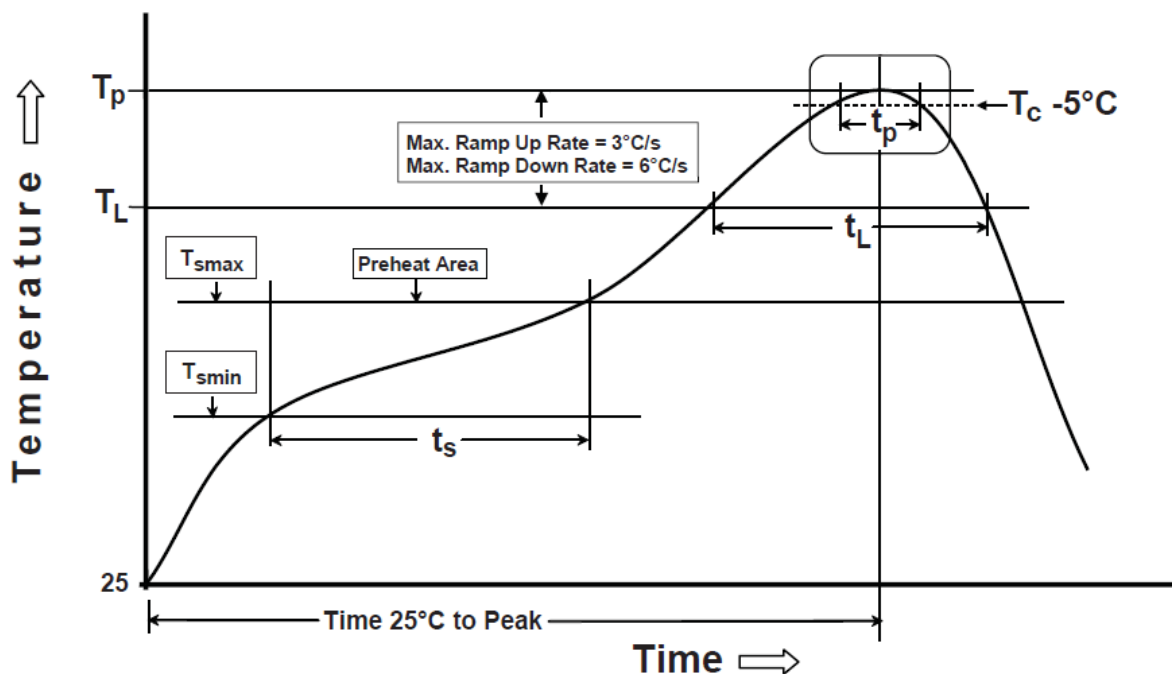

Changelog for the datasheet

SPE-15-8-040 – LA.02

Revision: E (Current Version)

Date:	2023-03-31
Changes:	Full datasheet update
Changes Made by:	Cesar Sousa

Previous Revisions

Revision: D

Date:	2023-03-13
Changes:	Added Antenna Integration Guide
Changes Made by:	Cesar Sousa

Revision: C

Date:	2021-11-1
Changes:	Format Change, MSL
Changes Made by:	Erik Landi

Revision: B

Date:	2021-05-18
Changes:	Amended Footprint drawing
Changes Made by:	Erik Landi

Revision: A (Original First Release)

Date:	2016-06-17
Notes:	Initial Release
Author:	STAFF



www.taoglas.com

