



NB-IOT & GNSS PHONE

BG96 NB-IoT & GNSS Phone Technical Specifications & User Manual



Purpose of the Document

The purpose of this document is to explain the technical specifications and manual for using the NB-IoT & GNSS Phone.

Document History

Version	Author	Date	Description
A	5G HUB	01.02.2021	Initial Document

Table of Contents

Purpose of the Document	2
Document History	2
1 Package contents:	4
1.1 NB-IoT & GNSS Phone Package	4
1.2 Download	4
2 General Description	5
2.1 Overview	5
2.2 Key Features.....	5
2.3 Overview Diagrams	7
2.4 Physical Characteristics	8
2.5 Peripherals – Key Components	9
2.6 Peripherals – IO Connections.....	12
2.7 Hardware Specification	13
2.8 PIN Description.....	14
2.9 BG96 chipset	15
2.10 Interface between SAM21D and BG96	15
3 References.....	16

1 Package contents:

1.1 NB-IoT & GNSS Phone Package

- NB-IoT & GNSS modem with full-color LCD, keypad, re-chargeable battery, SD card in a phone-like shape.

1.2 Download

Arduino software can be downloaded from the following website:

<https://github.com/5ghub/5G-NB-IoT/tree/master/KitSketches>

To use the NB-IoT phone with Arduino IDE and starts running Arduino projects and sketches, install the following software:

Install Arduino IDE for Windows from the following website

<https://www.arduino.cc/en/Main/Software>

Download and Install LTE&GNSS modem driver for Windows OS:

<https://github.com/5ghub/5G-NB-IoT/tree/master/Driver>

Download and Install QNavigator & QCOM tools for Quectel BG96 here:

<https://github.com/5ghub/5G-NB-IoT/tree/master/Tools>

Download and install Arduino library (**5G-NB-IoT_Arduino.zip**) here:

<https://github.com/5ghub/5G-NB-IoT>

All the following software can be installed from the GitHub location here:

<https://github.com/5ghub/5G-NB-IoT>

The NB-IoT phone Arduino sketches are in this folder:

<https://github.com/5ghub/5G-NB-IoT/tree/master/NBiotPhone>

[LTE cellular connectivity on Windows OS](#)

2 General Description

2.1 Overview

The NB-IoT & GNSS IoT phone is like a real phone. It is a cellular NB-IoT and GPS device that can be used for the 5G wireless technology. The phone has a keypad and full-color TFT LCD display with LTE & GNSS antenna connectors (or on-board antennas). The phone is a powerful board that features a microcontroller, wireless modem, keypad, a full-color TFT LCD, re-chargeable battery, and SD card. The microcontroller is an Atmel's SAMD21G18A MCU which features a 32-bit ARM Cortex® M0+ core. The wireless modem is BG96 which is an embedded IoT (LTE Cat-M1, LTE Cat-NB1 and EGPRS) wireless communication module. BG96 wireless modem provides a maximum data rate of 375Kbps downlink and 375Kbps uplink. It features ultra-low power consumption, provides data connectivity on LTE-TDD/LTE-FDD/GPRS/EDGE networks, and supports half-duplex operation in LTE networks. It also provides GNSS to meet customers' specific application demands.

The LCD is a full-color, 2.4 inch with 240x320 pixel resolution. The Keypad consist of 25 keys covering numbers, alphabets, characters, Up/Down/Right/Left buttons, and functions buttons. The IoT phone can be powered from either a UCB power source or a re-chargeable battery.

The IoT phone provides rich sets of Internet protocols, industry-standard interfaces (USB/UART/I²C/Status Indicator) and abundant functionalities. The board offer a high integration level and enables integrators and developers to easily design their applications and take advantage of the board low power consumption, many functionalities, and USB drivers for Windows 7/8/8.1/10, Linux and Android.

The NB-IoT phone mimics real cellular phone and is a rich hardware board that can be used for the latest 5G wireless technology and enables a variety of smart and 5G applications for devices, and acts as a great educational tool for learning about 5G and 32-bit application development. It enables large number of applications such as wireless POS, smart metering, tracking, smart transportation, smart buildings, smart city, and smart homes.

The NB-IoT phone is also compatible with Arduino and Arduino software (IDE). Arduino sketches and examples are provided with the kit and additional sketches can be developed and uploaded to the board.

2.2 Key Features

- Atmel ATSAMD21G18 MCU
- Quectel BG96 NB-IoT module
- Full-color, 2.4 inch with 240x320 pixel resolution LCD
- 25-buttons keypad with backlight LEDs
- SD Card slot
- Can be powered and charging a re-chargeable battery
- Supports LTE NB-IoT and Machine Type Communications (MTC)
- Supports EGPRS
- Global Frequency Band B1/B2/B3/B4/B5/B8/B12/B13/B18/B19/B20/B26/B28/B39 (B39 for Cat.M1 only) for LTE and 850/900/1800/1900MHz for EGPRS
- Supports the protocols TCP/UDP/PPP/ SSL/ TLS/ FTP(S)/ HTTP(S)/ NITZ/ PING/ MQTT
- Supports SMS
- Supports GNSS technology (GPS, GLONASS, BeiDou/Compass, Galileo, QZSS)

- Compact board size of 65 mm x 30mm
- Nano USIM card slot
- Arduino IDE Compatible
- Works with Windows, Linux, or Android
- Ready for smart applications and development (smart home, smart city, smart transportation, smart metering, smart farming, smart waste management, asset tracking, location, navigation, mapping, and timing applications). Application such as Gas Detector, Soil PH Tester, Optical Sensor, Machinery Alarm System, Irrigation Controller, Elevator, Asset Tracking Electronics, Person/Pet Tracking, Water/Gas Metering, Smart Parking System, Fire Hydrant, Smoke Alarm, Trash Bin, Street Lighting
- The board can be powered via the USB connector
- Each of the 14 general purpose I/O pins on the board can be used for digital input or digital output using [pinMode\(\)](#), [digitalWrite\(\)](#), and [digitalRead\(\)](#) functions. Pins used for PWM can be using [analogWrite\(\)](#) function. All pins operate at 3.3 volts. Each pin can source or sink a maximum of 10 mA and has an internal pull-up resistor (disconnected by default) of 20-60 K ohm.

2.3 Overview Diagrams

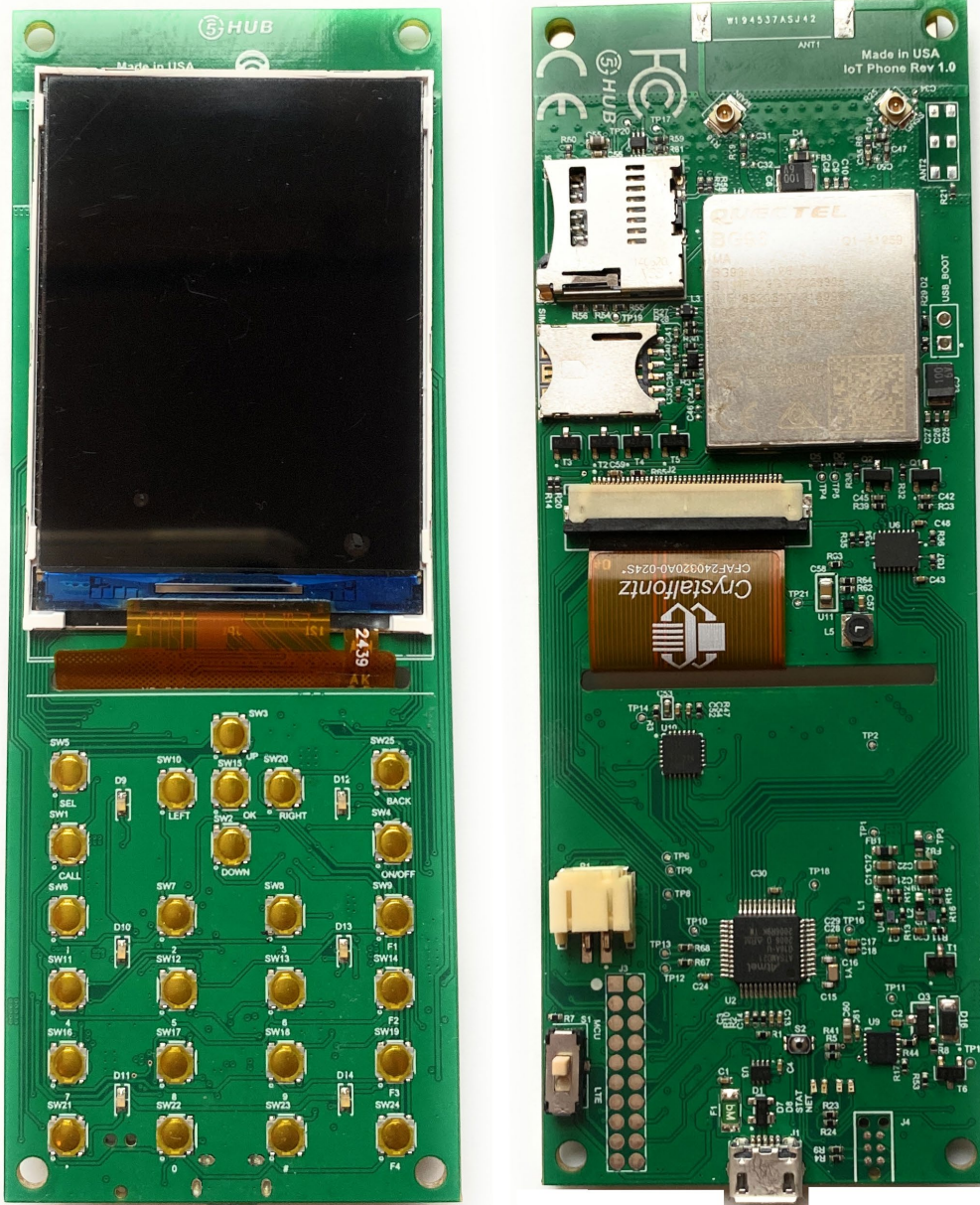

Figure 1. NB-IoT Phone Overview Diagram – Top & Bottom Views

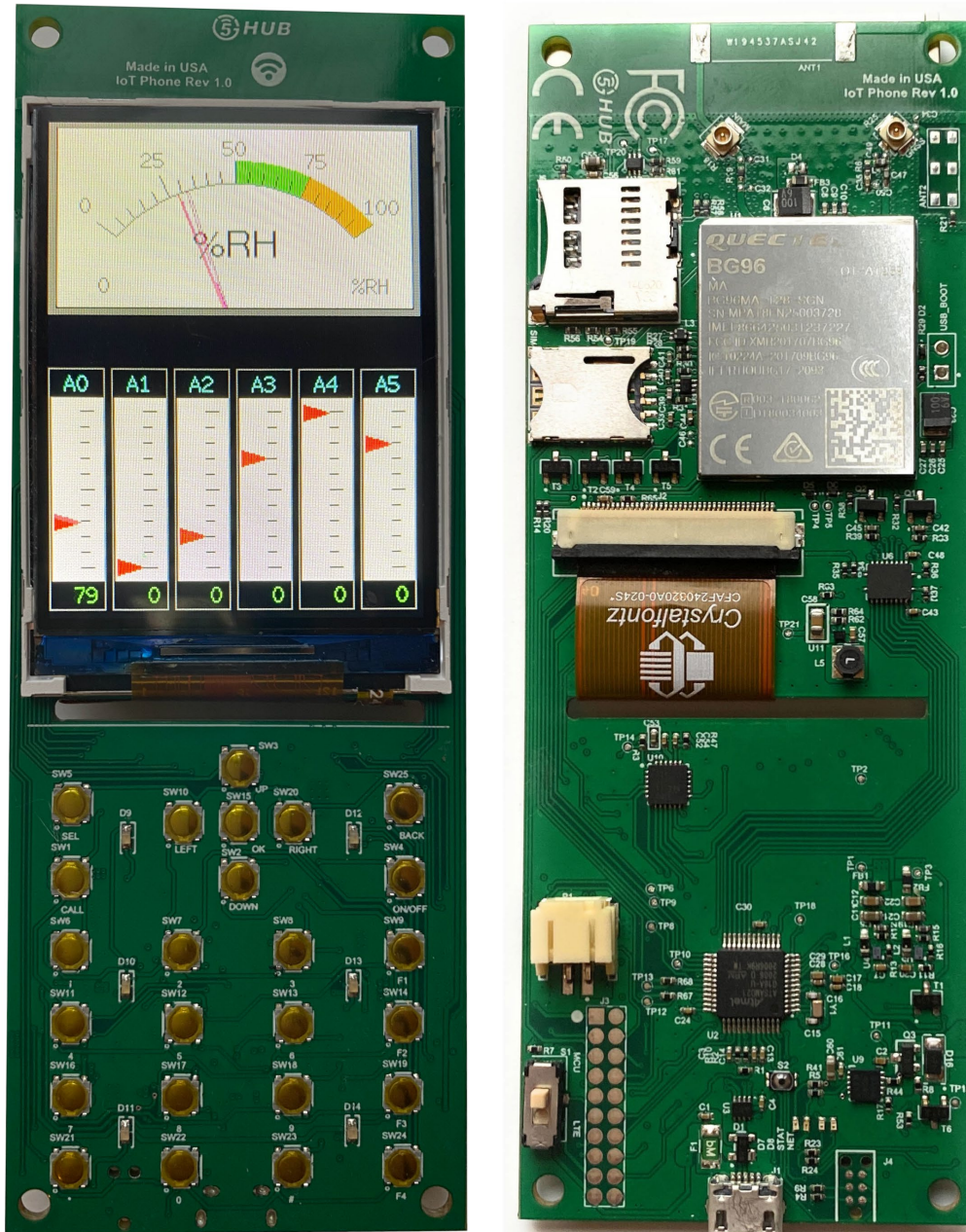

Figure 2. NB-IoT Phone Top View – LCD is ON

2.4 Physical Characteristics

The width and length of the IoT phone is 64 mm (width) by 123 mm (length). The board has four screw holes in each corner that allows the board to be attached to a surface or case.

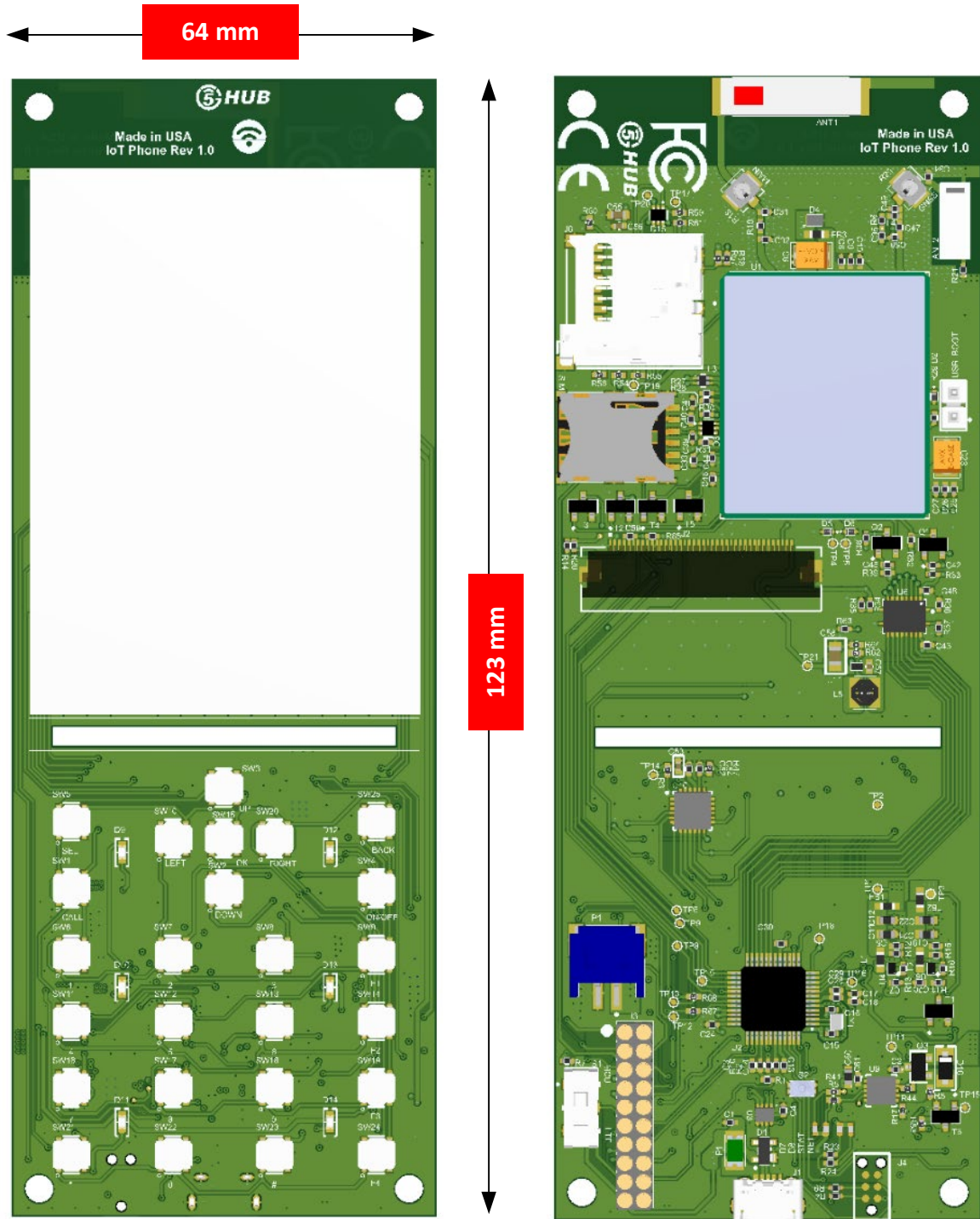

Figure 3. Physical Characteristics.

2.5 Peripherals – Key Components

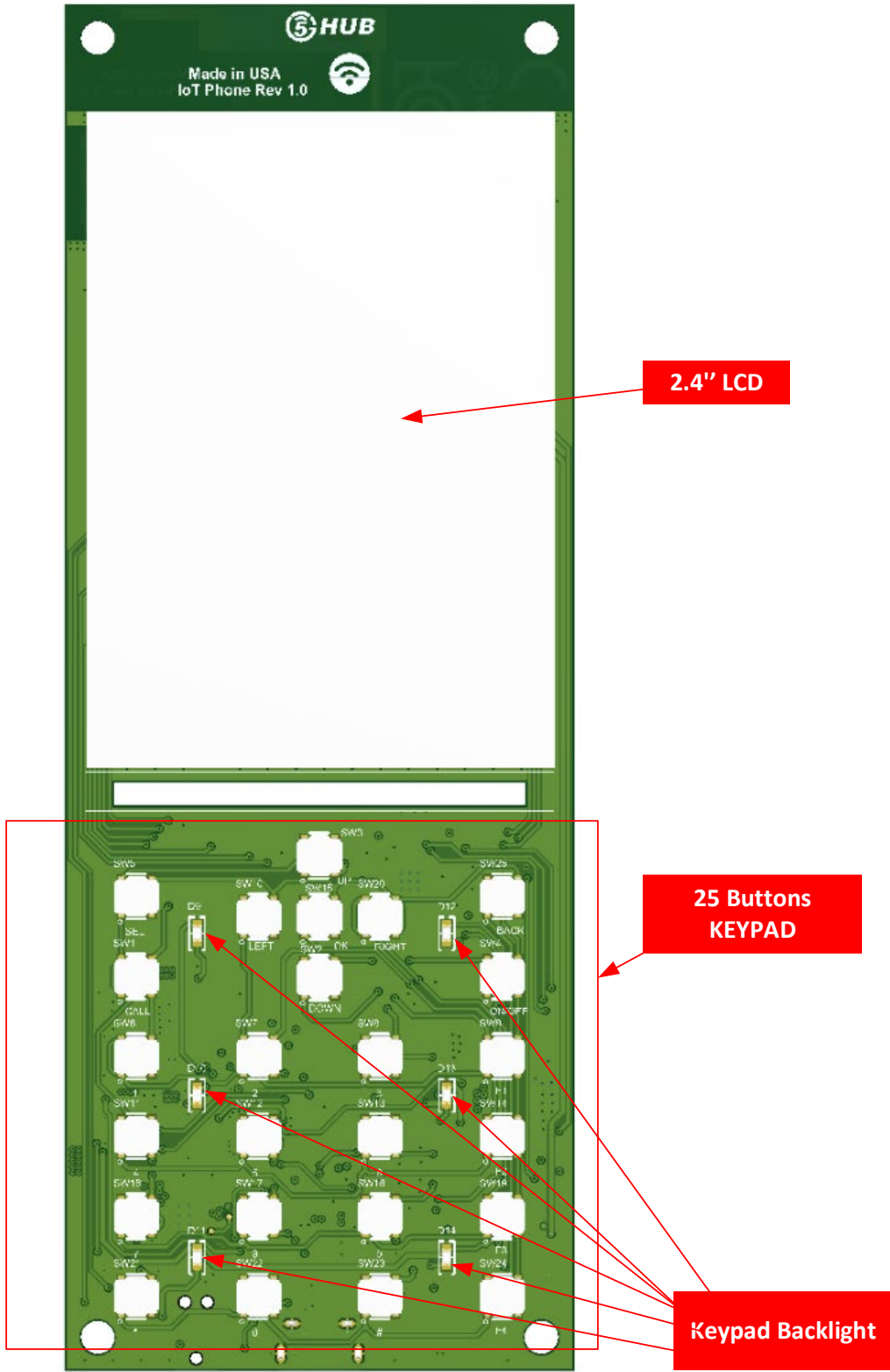

Figure 4. NB-IoT Phone Top Side – Key Components

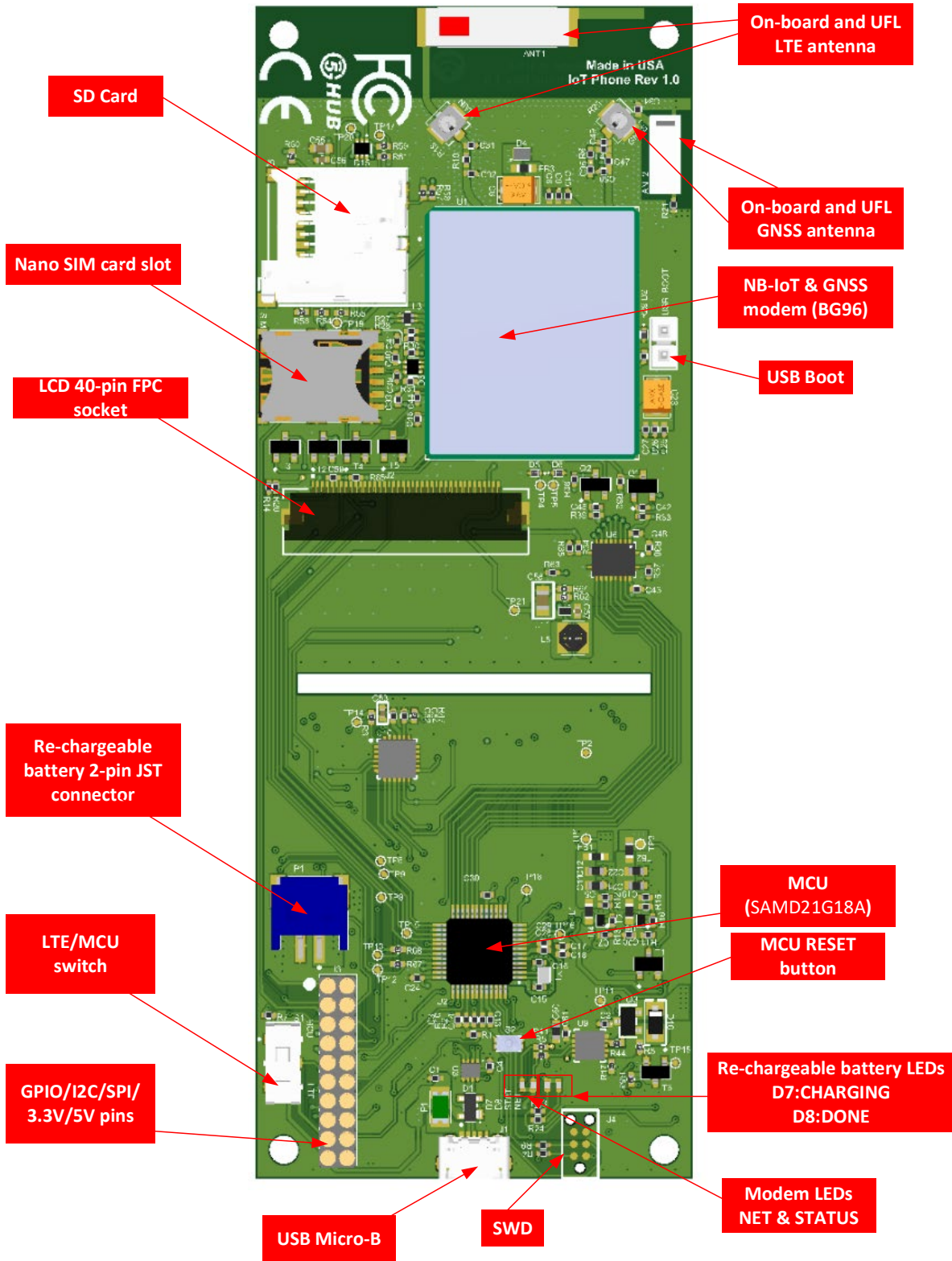

Figure 5. NB-IoT Phone Bottom Side – Key Components

2.6 Peripherals – IO Connections

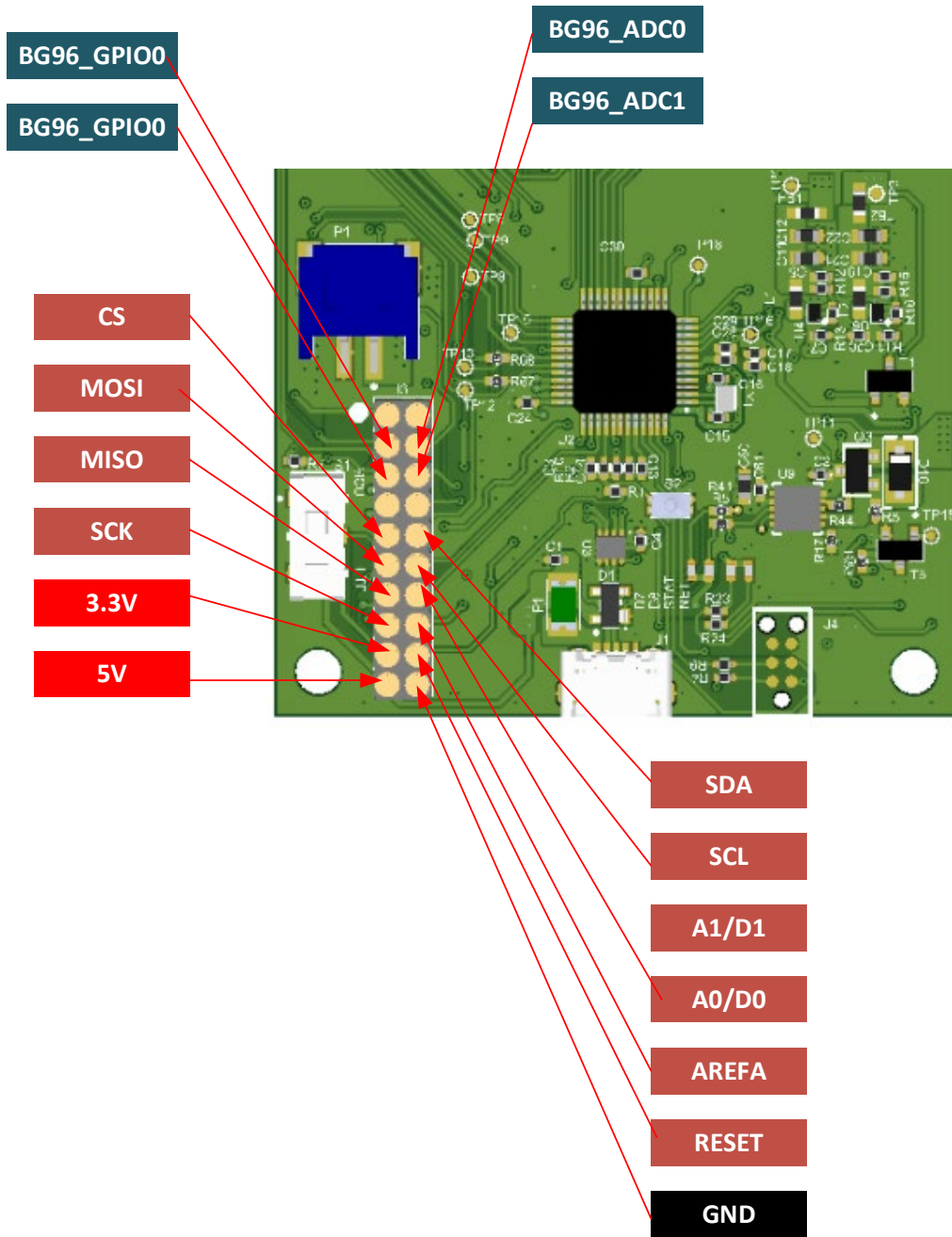

Figure 6. NB-IoT Phone Connectors

* I²C interface lines might be configured as USART interface (SDA line can work then as USART TXD and SCL line can work as USART RXD)

** MOSI and SCK lines might be configured as USART interface (MOSI line can work then as USART TXD and SCK line can work as USART RXD)

2.7 Hardware Specification

Technical Specification	
Microcontroller (MCU)	Atmel ATSAM21G18, 32-Bit ARM Cortex M0+
Clock Speed	48 MHz
Flash Memory	256 KB
SRAM	32 KB
NB-IoT Module	Quectel BG96
Dimension	64 mm (width) by 123 mm (length)
Weight	30 grams
Power Supply	USB (5V), re-chargeable battery
Keypad	25 buttons keypad
LEDs	Two modem LEDs: Status LED, Netlight LED; Keypad: 6 LEDs as backlight LEDs; Re-chargeable battery: 2 LEDs
LCD	Full-color 2.4 inch, 240x320 pixel resolution
Re-chargeable battery	One circuit for re-chargeable battery
SD Card	1
Interfacing Logic Voltage Level (Operating Voltage)	3.3V
Voltage output	5V, 3.3V
RESET buttons	one for MCU
USB Switch	1 switch to connect to MCU directly or BG96 directly
General-purpose digital I/O Pins	8 (A0/A1, D0/D1, CS, MOSI, MISO, SCK, SDA, SCL)
Modem GPIO	2 connected to BG96
Modem ADC	2 connected to BG96
USB	1
I ² C	1
SPI	1
GPIO	2
UART	1
ADC pins	2 (8/10/12-bit ADC channels)
DAC pin	2 (10-bit DAC)
External interrupts	8 (All general-purpose PINs)
PWM pin	2
DC Current per I/O Pin	10 mA
JTAG Debug	Cortex Debug Connector (Single Wire Debug)
USIM	Nano
GNSS	GPS, GLONASS, BeiDou/Compass, Galileo, QZSS
Antenna	1 main antenna and 1 GPS antenna
Band	LTE-FDD, B1/B2/B3/B4/B5/B8/B12/ B13/B18/B19/B20/B26/B28 LTE-TDD: B39 (for Cat M1 only)
Certification	FCC, CE
Mobile Operator Certification	Verizon and currently for AT&T

Notes:

- UART can be programmed through any of general-purpose pins.
- SPI can be programmed through any of general-purpose pins.

2.8 PIN Description

PIN	DIRECTION	Description
USB Connector	I	The NB-IoT Phone is powered from the USB port (3.8V-5V) or from re-chargeable battery
JST Connector (Re-chargeable battery)	IO	2-pin connector for re-chargeable battery. Provides power from the re-chargeable battery and recharge the battery
Keypad LED	O	Six keypad Backlight LEDs
LCD	O	2.4 inch, full color, 240x320 pixel resolution TFT LCD
LED (NET)	O	Indicate the BG96 operation status
LED (STAT)	O	Indicate the BG96 network activity status
Re-chargeable battery LED	O	Two LEDs indicating whether the re-chargeable battery is charging or is done charging and full
SD Card	IO	One SD card slot
MCU RESET button	I	Reset the MCU
USB Switch	I	1 switch to connect to the USB port directly to MCU or BG96
3.3V	O	3.3V generated by the on-board regulator. Maximum current drawn is 3A. The regulator also provides power to the MCU and BG96
5V	O	5V generated from the board. The board is supplied with power from USB connector (typical 5V)
GND		Ground
A0	IO	Two analog inputs which can provide up to 12 bits of resolution (i.e. 4096 different values). By default, each input measures from ground to 3.3 volts, though is it possible to change the upper end of their range using the AREF pin A0 can also be used as a DAC output and provides a 10 bit voltage output with analogWrite() function Analog pins can be used as GPIOs
A1	IO	
SCL	IO	I ² C. The SCL (clock line). Can be used as GPIO
SDA	IO	I ² C. The SDA (data line). Can be used as GPIO
AREFA	I	Input reference voltage for the analog inputs used for either the ADC or the DAC
SCK	IO	SPI Interface. Can be used as GPIO
MISO	IO	SPI Interface. Can be used as GPIO
MOSI	IO	SPI Interface. Can be used as GPIO
CS	IO	SPI Interface. Can be used as GPIO
D0	IO	GPIO. Can be used as GPIO
D1	IO	

Cortex Debug Connector	IO	Using Single Wire Debug to burn bootloader and debug the board.
Modem ADC0	I	Connected to BG96. General purpose analogue to digital converter
Modem ADC1	I	Connected to BG96. General purpose analogue to digital converter
Modem GPIO0	IO	Connected to BG96. General purpose IO
Modem GPIO1	IO	Connected to BG96. General purpose IO
USIM	I	Used to insert a Nano USIM. Connected to BG96
USB Boot	I	Connected to BG96. Force the BG96 to enter emergency download mode

Precaution

The NB-IoT phone runs at 3.3V. The maximum voltage that the I/O pins can tolerate is 3.3V. Applying voltages higher than 3.3V to any I/O pin could damage the board

2.9 BG96 chipset

All functionality of the BG96 chipset shall be implemented excluding the following features. That is, the following features are not supported [1][2].

- Audio, Earphone, and Codes are not supported.
- PCM and I²C are not supported
- PSM_IND and AP_READY are not supported

2.10 Interface between SAM21D and BG96

The Microcontroller communicates with the BG96 through UART interfaces:

- **UART1:** (PA12/PA13/PA14/PA15). Used for data transmission and AT command communication 115200bps by default. The default frame format is 8N1 (8 data bits, no parity, 1 stop bit) Support RTS and CTS hardware flow control.
- **UART3:** (PB23/PB22). Used for outputting GNSS data or NEMA sentences 115200bps baud rate.

3 References

- [1] Quectel_BG96_Hardware_Design_V1.2.pdf
- [2] Quectel_BG96_Reference_Design_Rev.A_20170814.pdf
- [3] Quectel_Antenna_Design_Note_V2.0.pdf
- [4] Quectel_RF_Layout_Application_Note_V2.2.pdf
- [5] Quectel_QFlash_User_Guide_V2.3
- [6] Arduino IDE, <https://www.arduino.cc/en/Main/Software>
- [7] Arduino IDE, <https://www.arduino.cc/en/Guide/ArduinoZero>
- [8] Microchip, “Low-Power, 32-bit Cortex-M0+ MCU with Advanced Analog and PWM”