



TAOGLAS®



Datasheet

Low Profile and High Efficiency 868 MHz ISM Band Loop Antenna

Part No:
ILA.02

Description

868 MHz ISM Band Loop Antenna

Features:

- Small size antenna, low profile, and high efficiency
- 868 MHz ISM Band
- 1 dBi Peak Gain
- 10 x 3.2 x 0.5 mm size
- SMT Compatible
- RoHS & REACH Compliant

1.	Introduction	2
2.	Specification	3
3.	Antenna Characteristics	4
4.	Radiation Patterns	8
5.	Mechanical Drawing	10
6.	Packaging	11
7.	Antenna Integration Guide	13
8.	Solder Reflow Profile	20
<hr/>		
	Changelog	21

Taoglas makes no warranties based on the accuracy or completeness of the contents of this document and reserves the right to make changes to specifications and product descriptions at any time without notice. Taoglas reserves all rights to this document and the information contained herein. Reproduction, use or disclosure to third parties without express permission is strictly prohibited.

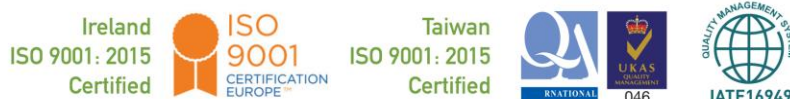

1. Introduction



The ILA.02 is a 868 MHz ISM band antenna featuring an excellent efficiency of 60% across the band. This antenna works the best when placed at the center of the board edge. The antenna, at 10 x 3.2 x 0.5 mm, is low profile and would be suitable for devices with space constraints. The ILA.02 is delivered on tape and reel and now allows M2M customers to use an omni-directional SMT antenna. The omni-directional radiation characteristics allow for excellent performance regardless of device orientation. This is especially useful for devices that are not fixed in one particular spot during use. When there is little PCB space available for antenna placement, but high performance is required, the ILA.02 is the ideal choice.

This antenna can be mounted with no performance degradation in either orientation as long as the antenna is soldered correctly via Surface mounting. Please see the integration instructions section for further detail regarding the optimum way to integrate this antenna into your device.

For further optimization to customer-specific device environments and for support to integrate and test this antennas performance in your device, contact your regional Taoglas Customer Services Team.

Applications:

- Automated Meter Reading (AMR)
- Radio Frequency Identification (RFID)
- Remote Monitoring
- Healthcare
- Sensing
- 868 MHz Applications

2. Specification

LTE Electrical

Band	Frequency (MHz)	Efficiency (%)	Average Gain (dB)	Peak Gain (dBi)	Impedance	Polarization	Radiation Pattern	Max. input power
868MHz	863-870	58.7	-2.31	0.95	50 Ω	Linear	Omni	5W

Mechanical

Dimensions (mm)	10 x 3.2 x 0.5
Required Space (mm)	11 x 10.4
Material	Ceramic
EVB Connector	SMA(F)

Environmental

Temperature Range	-40°C to 85°C
Storage Temperature	-40°C to 105°C
Humidity	40% to 95%
Moisture Sensitivity Level	3 (168 Hours)

3. Antenna Characteristics

3.1 Test Setup

AUT



Vector Network Analyzer

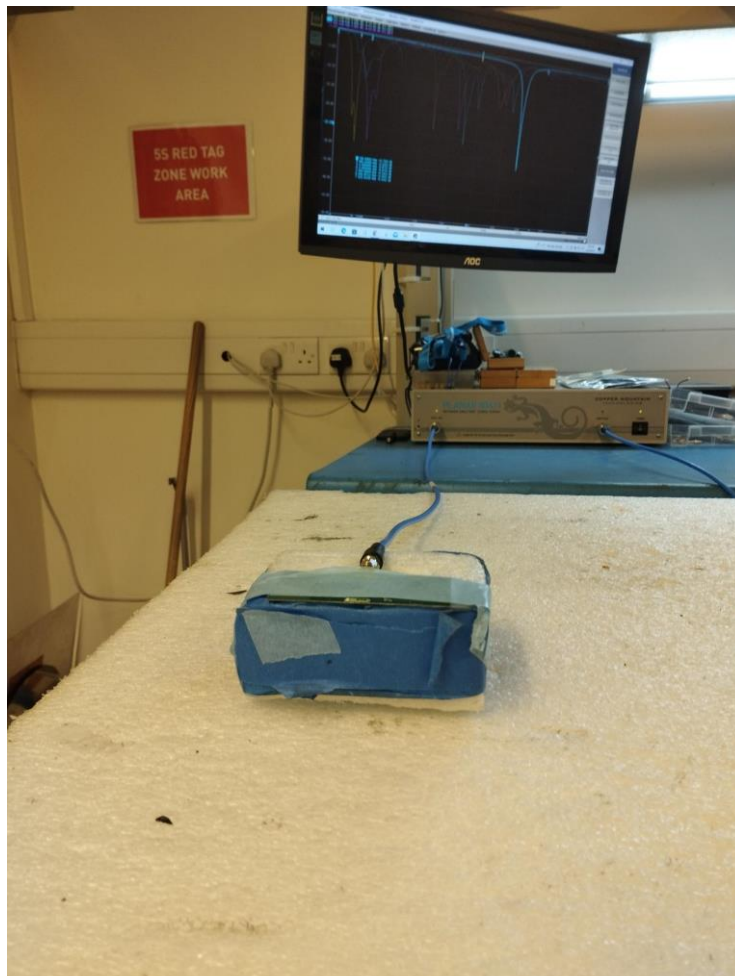

3.2 Return Loss

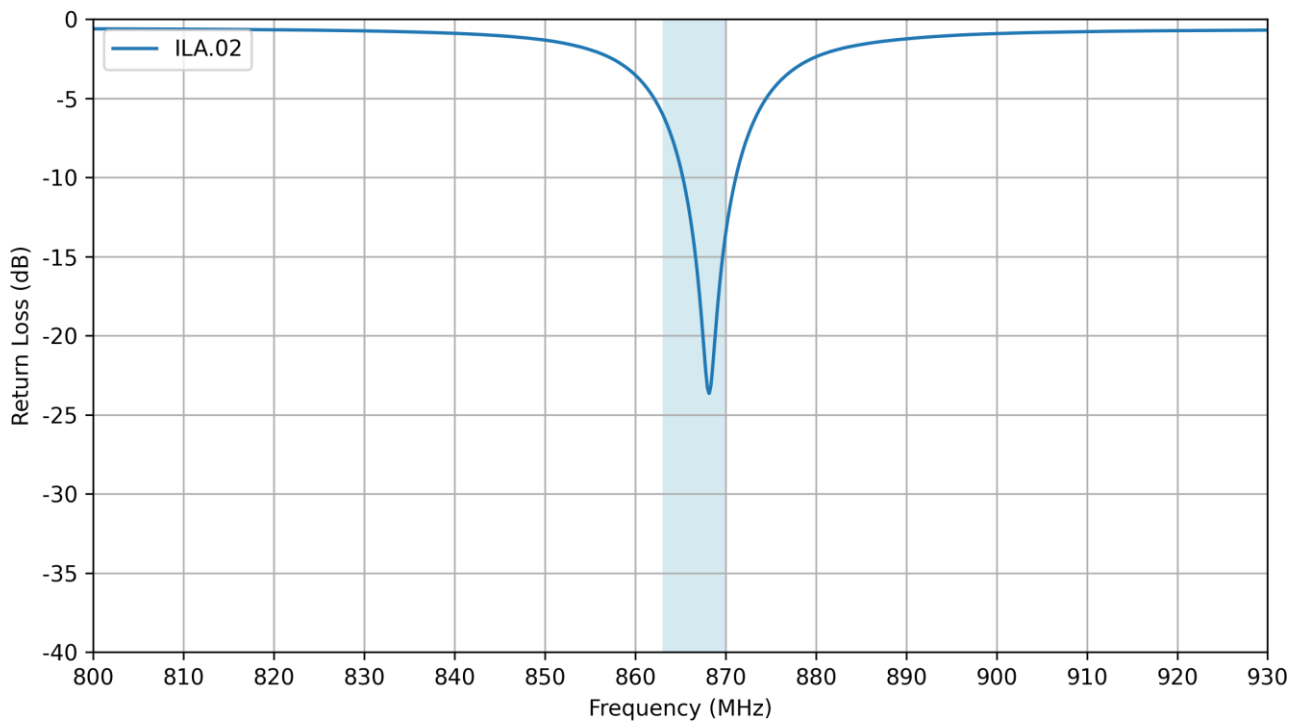

3.3 VSWR

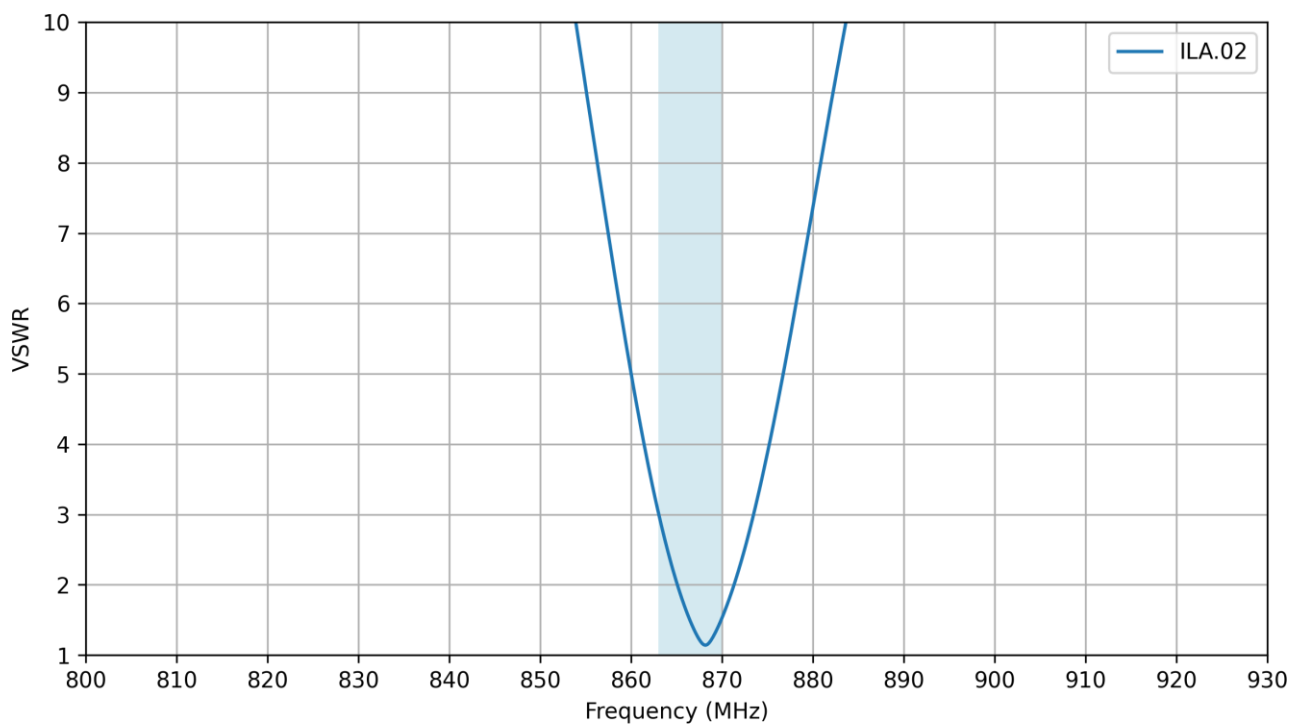

3.4 Efficiency

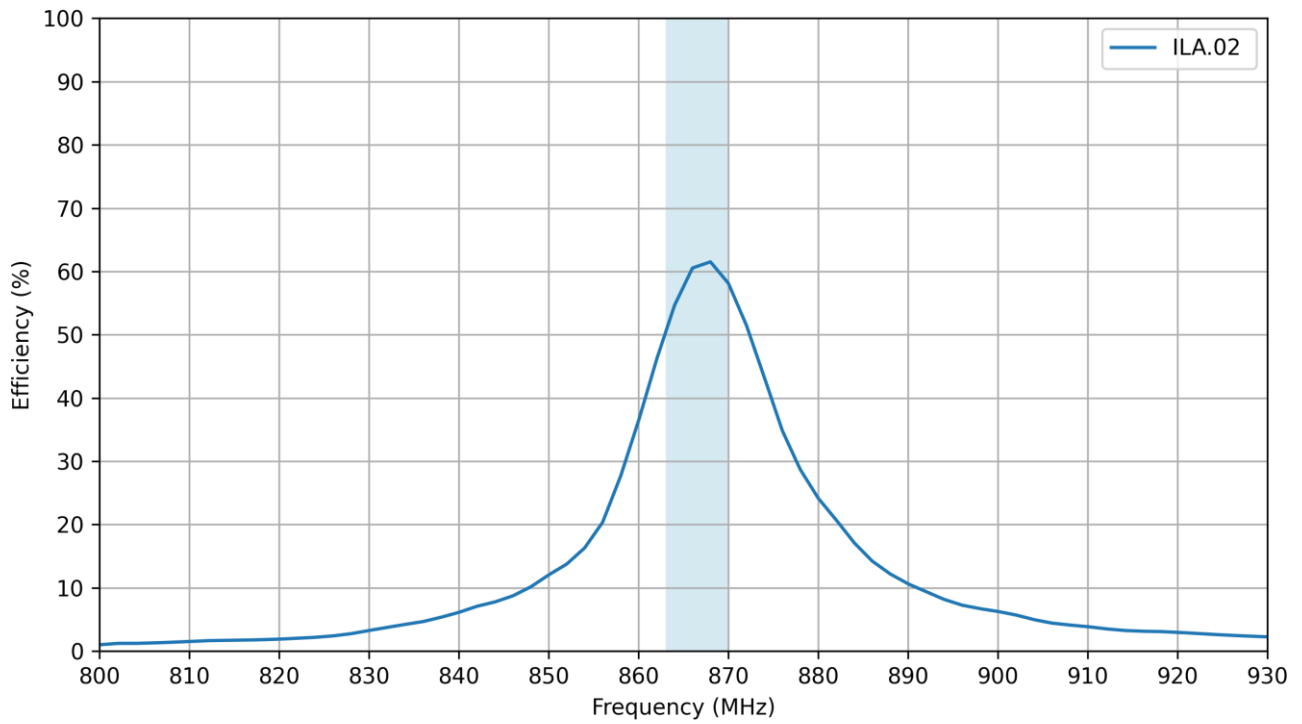

3.5 Average Gain

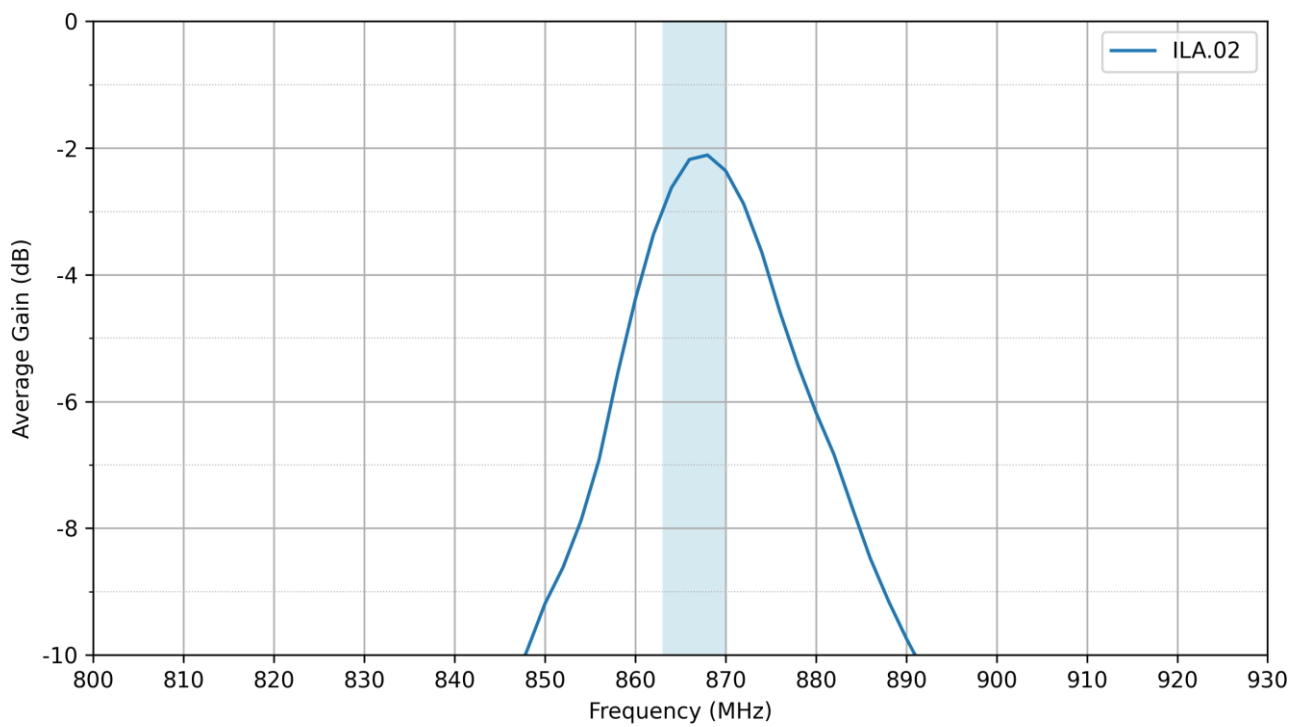

3.6 Peak Gain

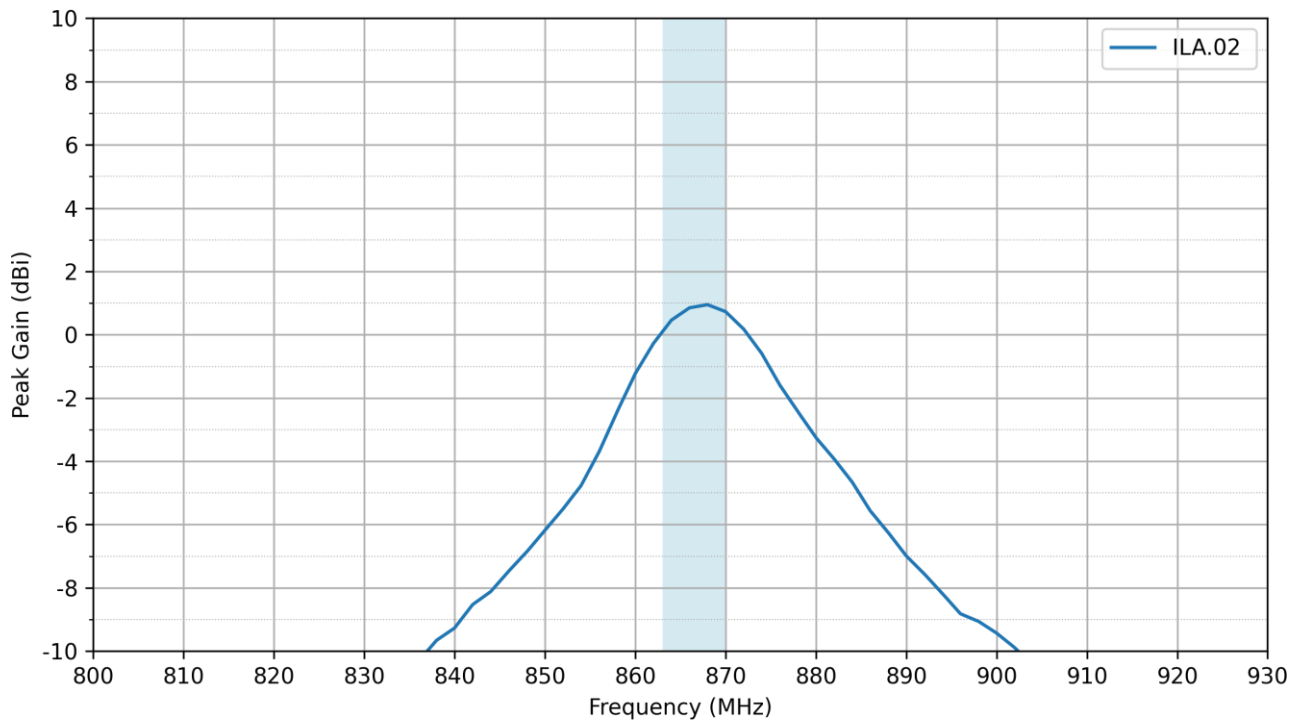

4. Radiation Patterns

4.1 Test Setup

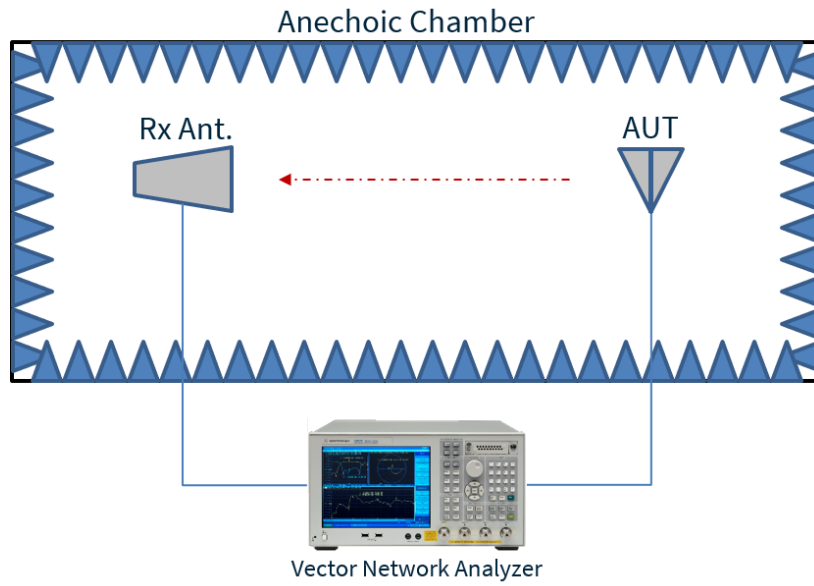

4.2 ILA.02 Patterns at 868 MHz

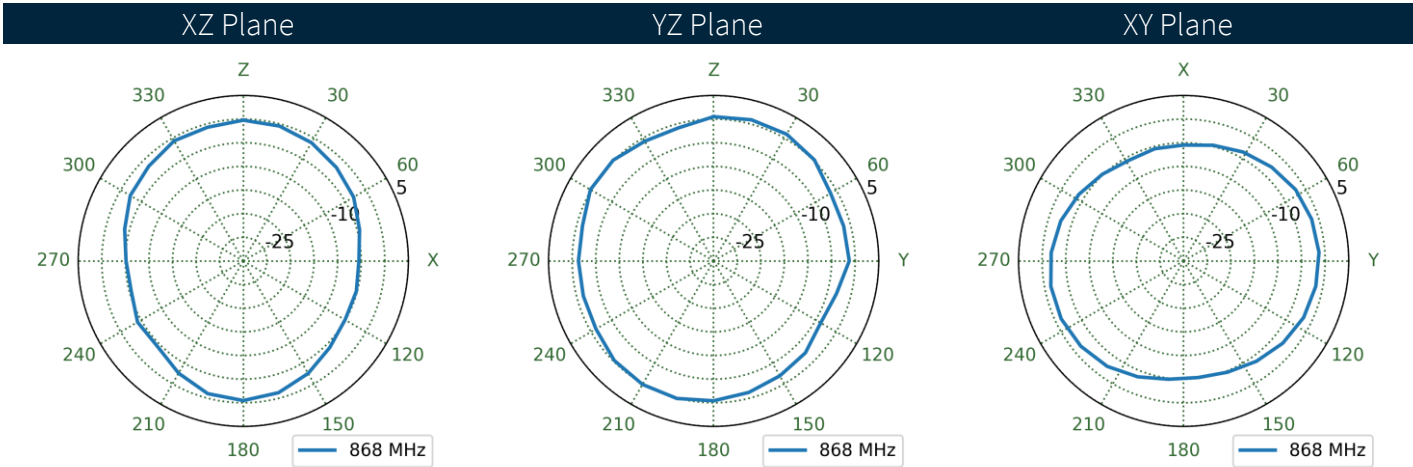
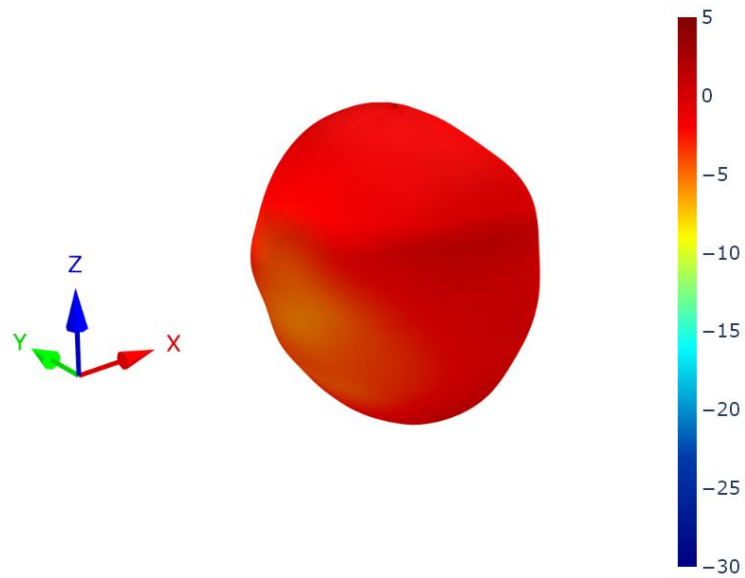

5. Mechanical Drawing

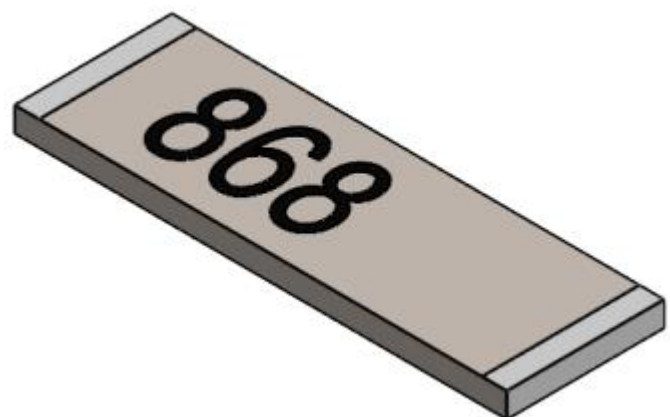
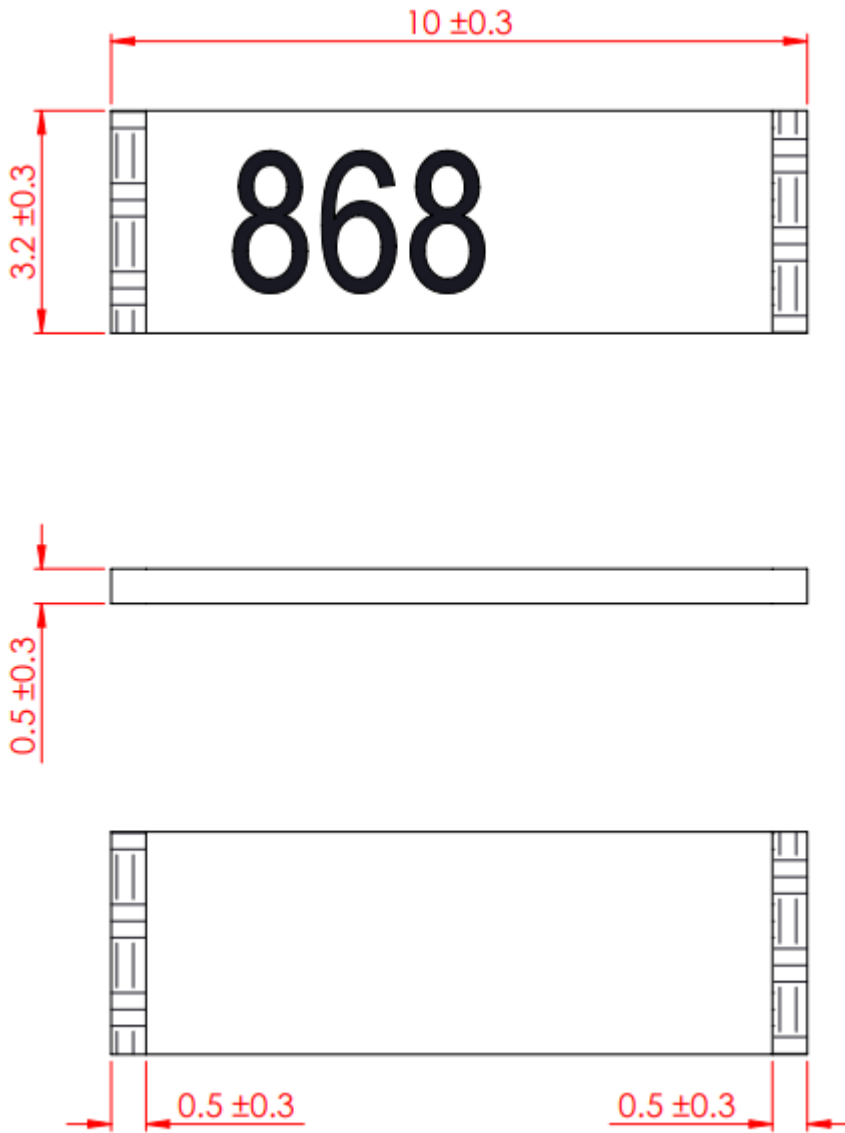

6. Packaging

6000 pcs ILA.02 reel
 Dimensions - 420*380mm
 Weight -1030g

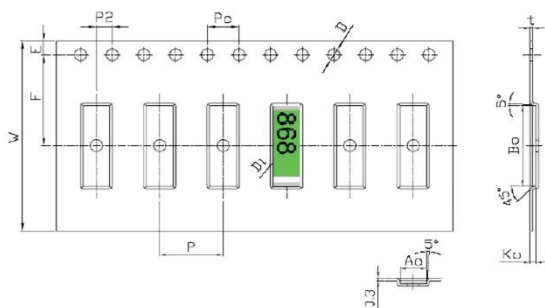
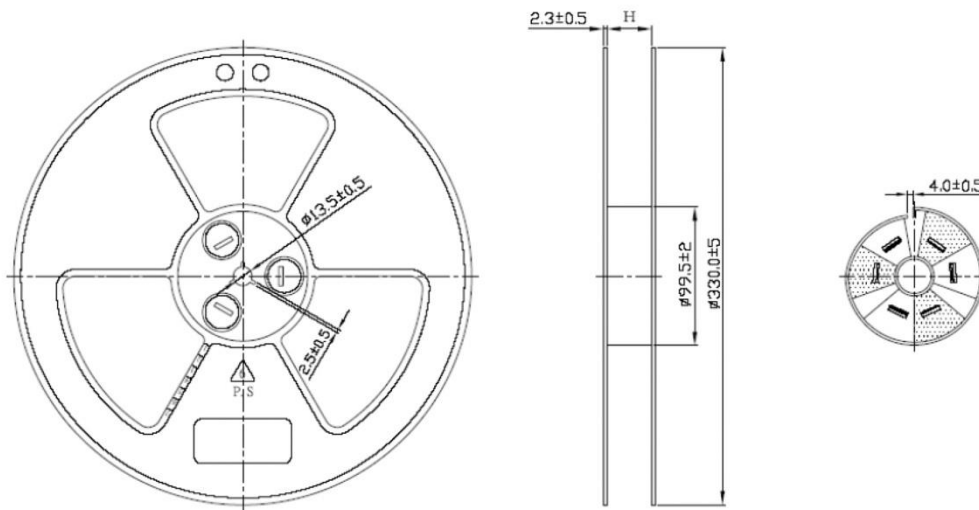

Tape Dimensions(unit: mm)

Feature	Specifications	Tolerances
W	24.00	± 0.30
P	8.00	± 0.10
E	1.75	± 0.10
F	11.50	± 0.10
P2	2.00	± 0.10
D	1.50	$+0.10$
		0.00
D1	1.50	± 0.10
Po	4.00	± 0.10
10Po	40.00	± 0.20

Pocket Dimensions(unit: mm)

Feature	Specifications	Tolerances
Ao	3.40	± 0.10
Bo	10.20	± 0.10
Ko	0.70	± 0.10
t	0.30	± 0.05

6000 pcs ILA.02 reel
Dimensions - 420*380mm
Weight -1030g

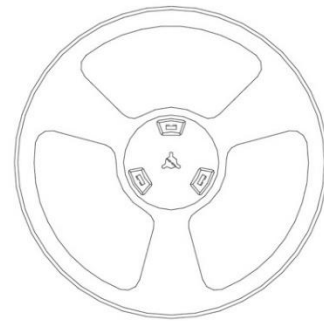

6 reels, 36000pcs
in one carton
Carton Dimensions - 350*350*210mm
Weight - 7Kg

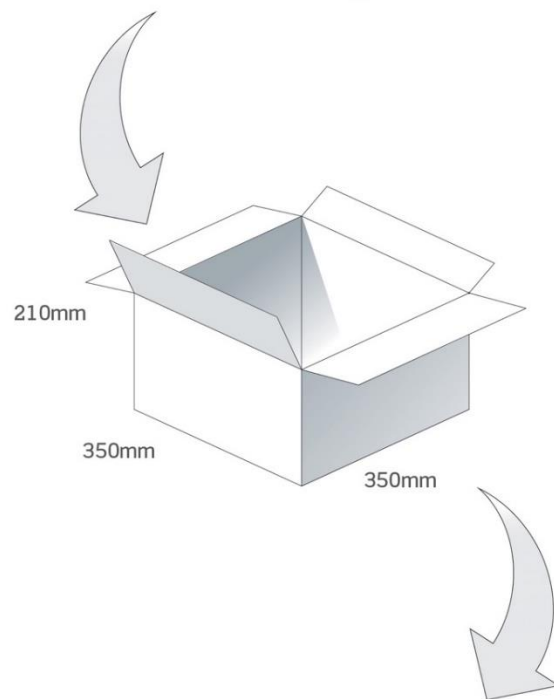

Pallet Dimensions 1200*1000*1460mm
36 Cartons per Pallet
6 Cartons per layer
6 Layers

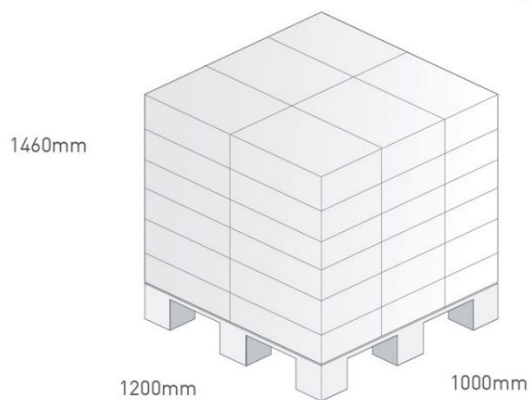

7. Antenna Integration Guide



7.1 Schematic and Symbol Definition

The circuit symbol for the antenna is shown below. The antenna has 4 pins with all pins as functional.

Pin	Description
1	RF Feed
2	Ground
3, 4	FTE (Fine Tuning Element)

TAOGLAS_ILA.02 ANT1

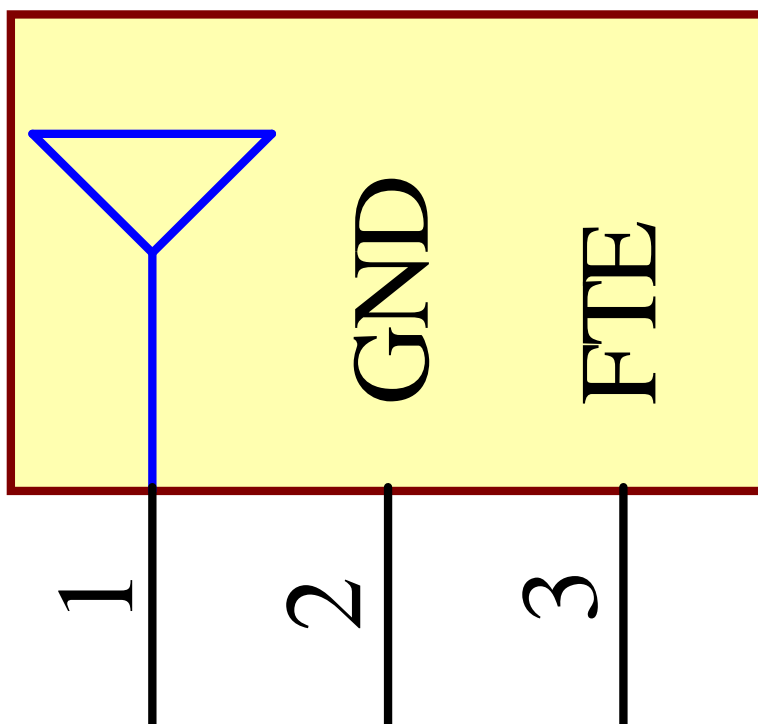

7.2 Antenna Integration

For any given PCB size, the antenna should ideally be placed on the PCB's longest side, to take advantage of the ground plane. Optimized matching components can be placed as shown.



With Solder Mask

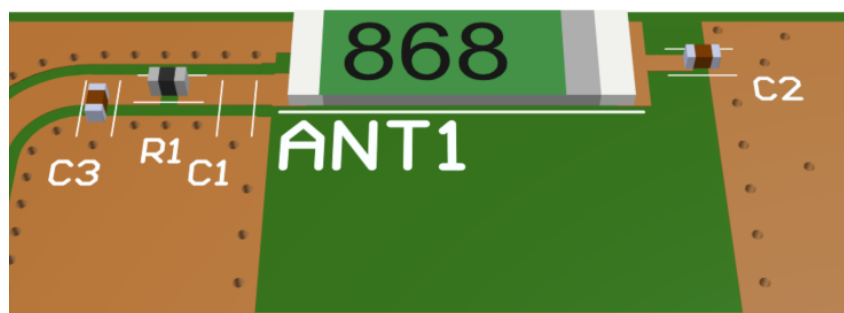

Without Solder Mask

7.3 PCB Clearance

Below shows the antenna footprint and clearance through ALL layers on the PCB. Only the antenna pads and connections to feed and GND are present within this clearance area (marked RED). The clearance area extends to 10mm in length and 12.8mm in width from the centre of the PCB's board edge mechanical pads to the ground area. This clearance area includes the bottom side and ALL internal layers on the PCB.

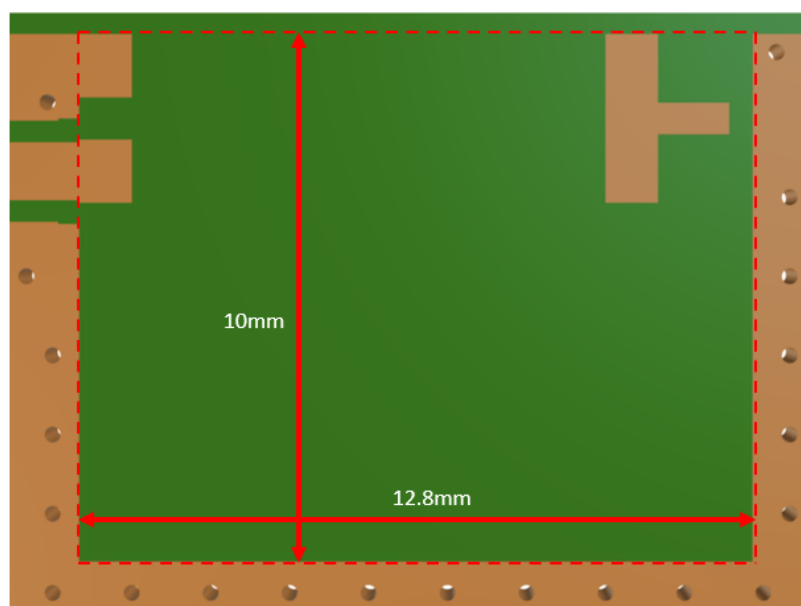

7.4 PCB Layout

The footprint and clearance on the PCB must meet the layout drawing in section 7.7. Note the placement of the optimized components. R1 is placed as close as possible to the RF feed (pad 1) in series connecting to ground. C3 is then placed tightly in parallel after that. C2 is placed close to the FTE (pad 3) as possible connecting to ground. C1 is an optional component but the footprint is recommended in case it is needed.

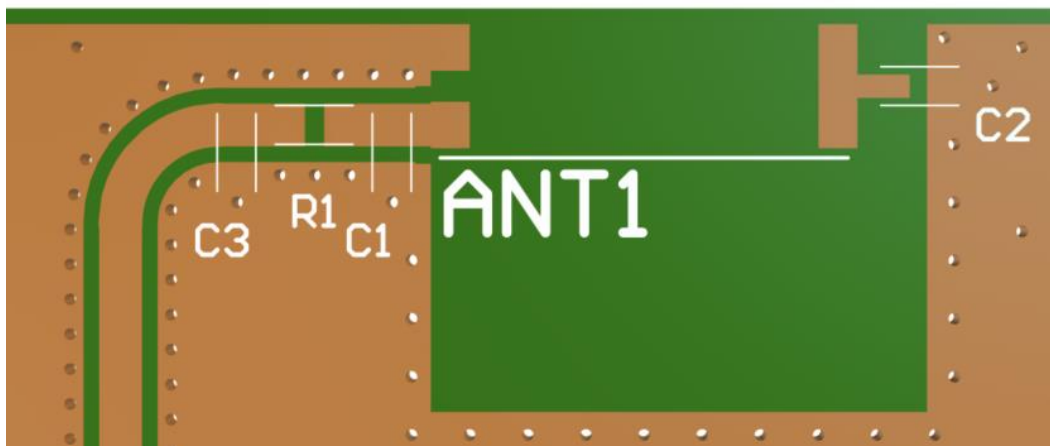
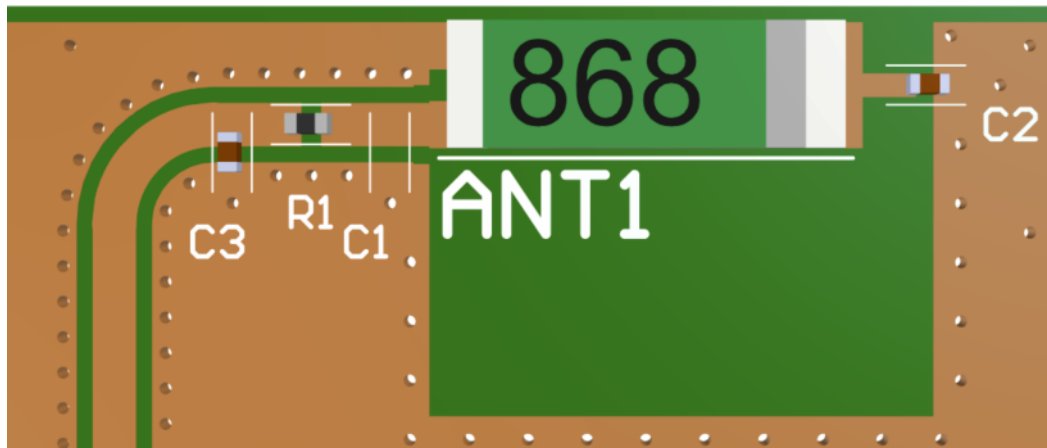

7.5 Evaluation Board



7.6 Evaluation Board Matching Circuit

Matching components with the ILA.02 are recommended for the antenna to have optimal performance on the evaluation board, located in the spaces specified in previous sections. Additional matching components may be necessary for your device, so we recommend incorporating extra component footprints, forming a “pi” network, between the cellular module and the edge of the ground plane.

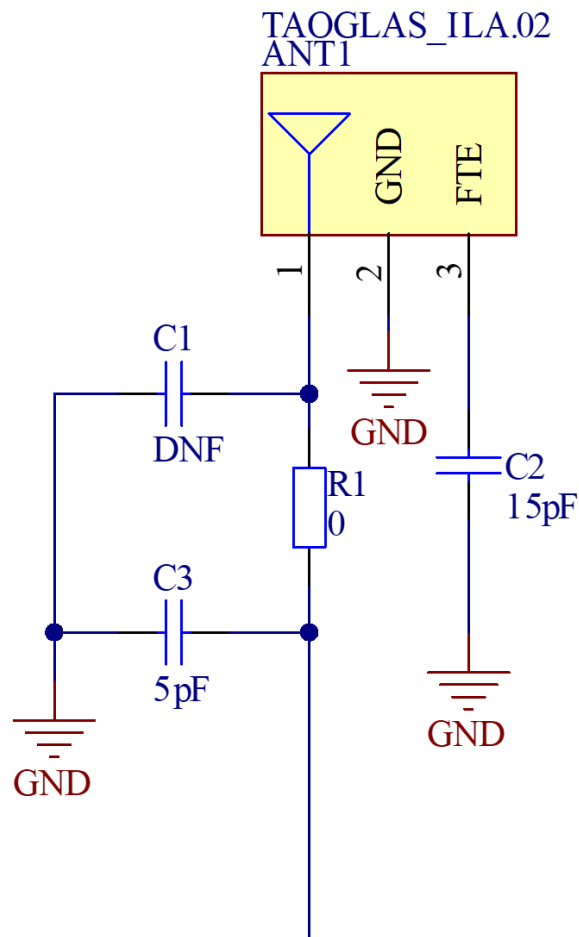

Designator	Type	Value	Manufacturer	Manufacturer Part Number
R1	Resistor	0 Ohms	Yageo	RC0402JR-070RL
C1	Capacitor	Not Fitted	-	-
C2	Capacitor	15pF	Murata Electronics	GRM1555C1H150JA01D
C3	Capacitor	5pF	Murata Electronics	GRM1555C1H5R0CA01D

7.7 Footprint

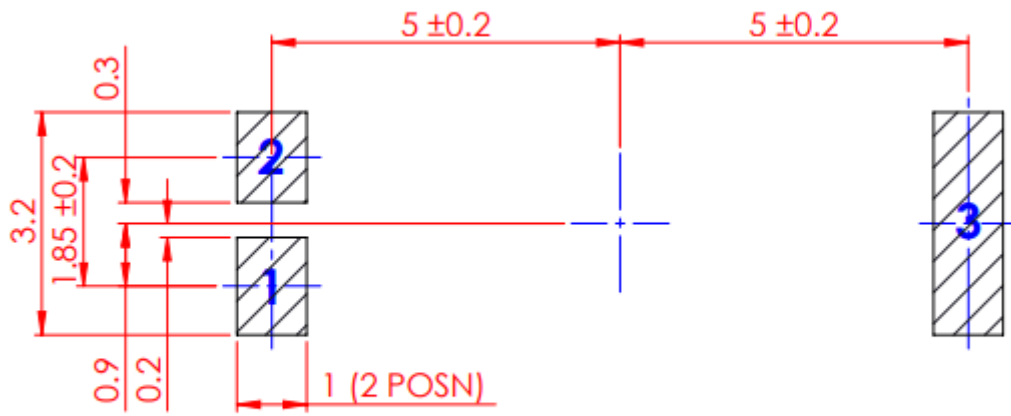

FOOTPRINT PCB

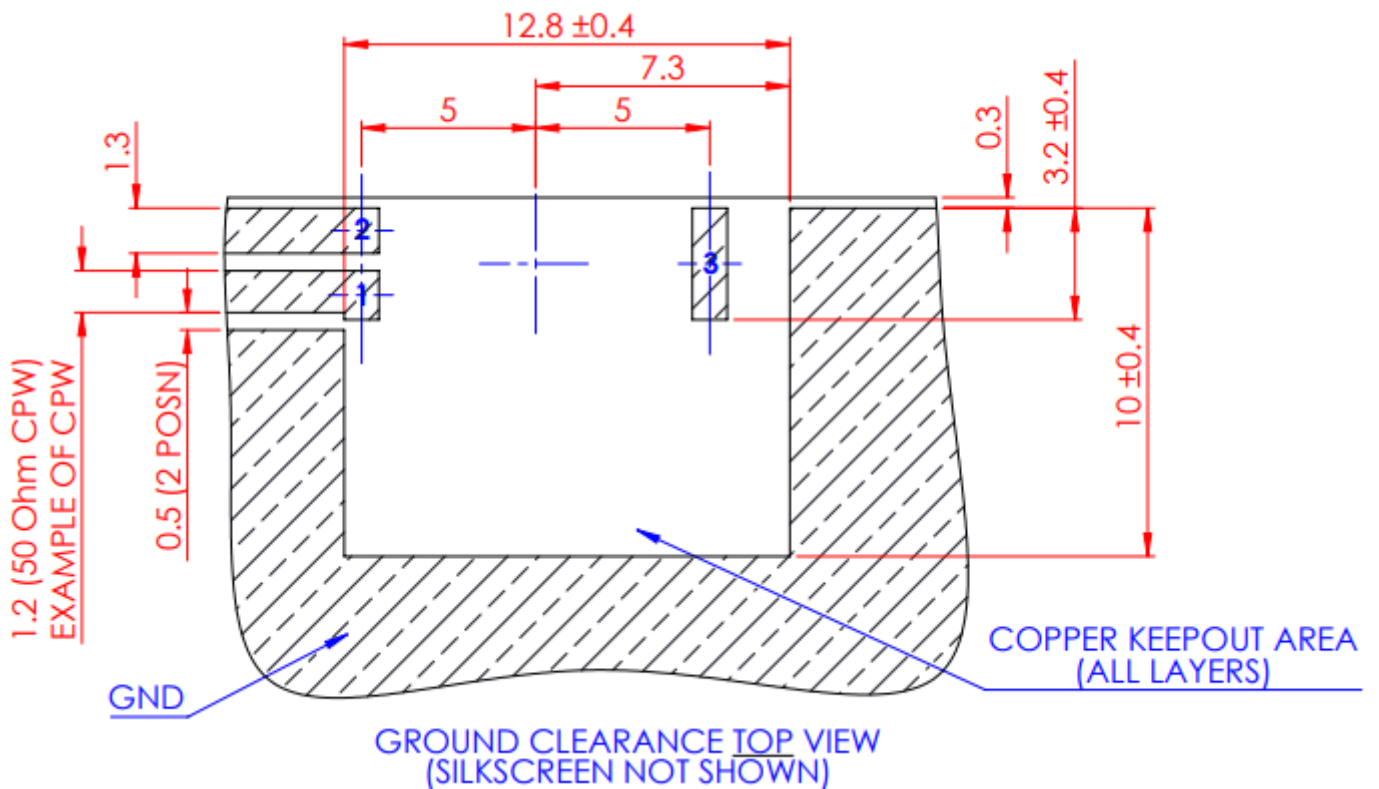

8. Solder Reflow Profile

Typical Soldering profile for lead-free process:

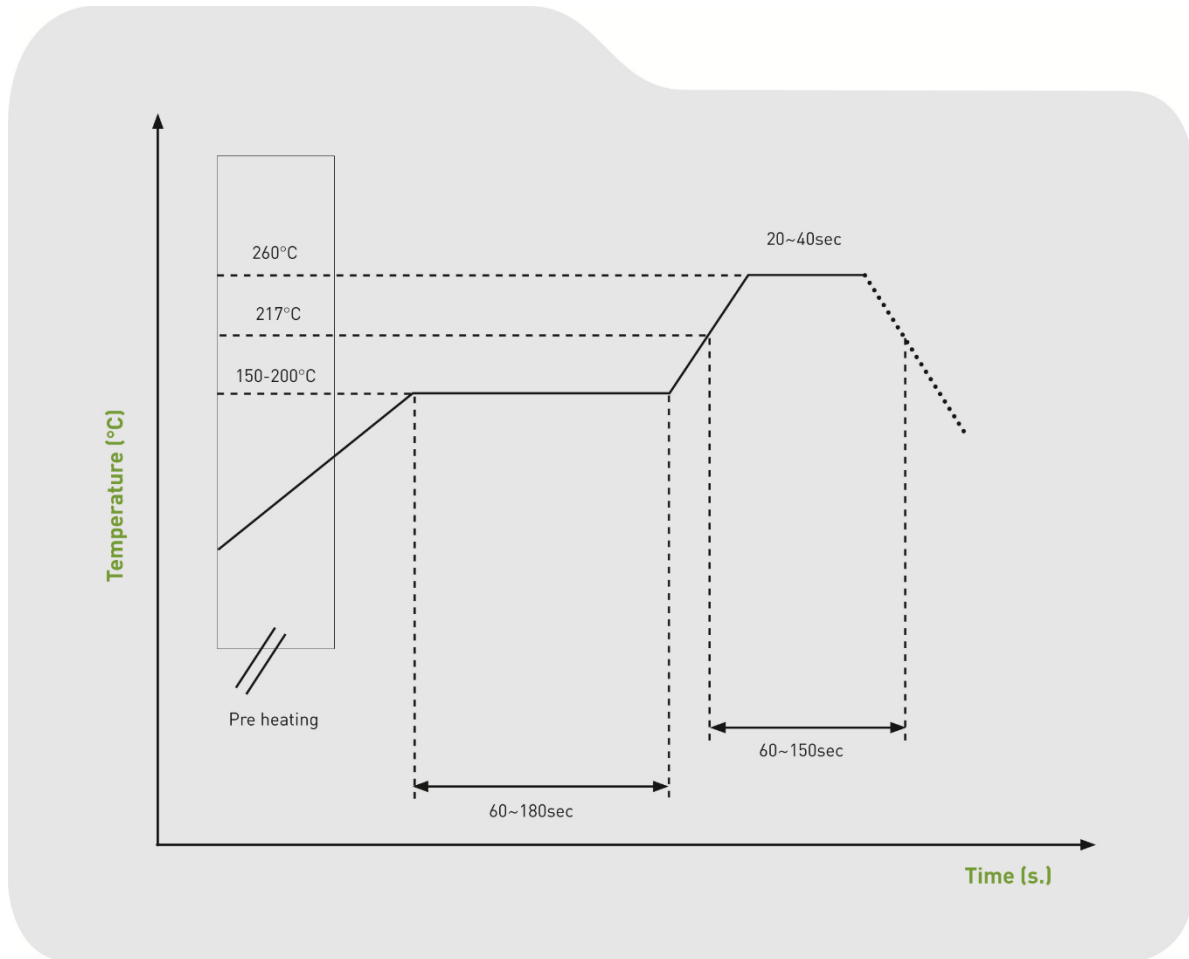

Changelog for the datasheet

SPE-12-8-080– ILA.02

Revision: J (Current Version)

Date:	2023-04-19
Changes:	Full datasheet update
Changes Made by:	Gary West

Previous Revisions

Revision: I

Date:	2023-01-17
Changes:	Updated image product
Changes Made by:	Cesar Sousa

Revision: D

Date:	2016-09-12
Changes:	
Changes Made by:	STAFF

Revision: H

Date:	2022-06-23
Changes:	Updated graphs , radiation patterns and Antenna Installation Guide
Changes Made by:	Evan Murphy

Revision: C

Date:	2014-08-19
Changes:	EVb & Footprint
Changes Made by:	AINE DOYLE

Revision: G (Current Version)

Date:	2021-10-28
Changes:	Format Change, MSL
Changes Made by:	Erik Landi

Revision: B

Date:	2012-06-27
Changes:	
Changes Made by:	STAFF

Revision: F

Date:	2017-10-23
Changes:	Packing drawing updated
Changes Made by:	Carol Faughnan

Revision: A (Original First Release)

Date:	2012-05-08
Notes:	Initial Release
Author:	STAFF

Revision: E

Date:	2017-04-21
Changes:	
Changes Made by:	STAFF



www.taoglas.com

