

iMCP HT32SX V2.2 – SiP Sigfox

Sigfox® Monarch RF Transceiver System-in-Package

OVERVIEW

The iMCP – HT32SX is a Multicomponent Integrated Circuit (MCO) designed to provide a ready-to-use connectivity solution for Internet of Things (IoT) applications. It provides both uplink (transmit) and downlink (receive) communications, and it is the first HT Micron product in a new family of non-memory components. Its small dimensions, high performance and low power consumption targets the best experience for IoT developers. It features an ARM Cortex M0+ 32bit (STM32L052x8) and the S2-LP low power transceiver from ST Microelectronics combined with the SKY66420 from Skyworks Solutions which provide all the performance advantages, integration, and convenience of advanced semiconductor packaging technology into a single chip. Please check if you have the most updated version of this document by downloading it from [THIS](#) repository.

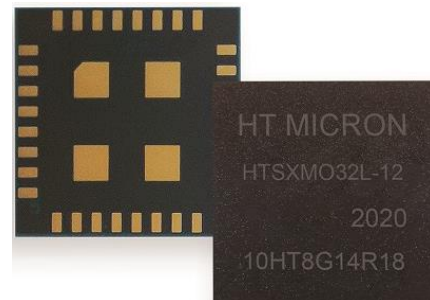

FEATURES

- Key features
 - Enables operations in the SIGFOX™ network
 - Multizone worldwide operation – MONARCH
 - ARM Cortex M0+ 32bit STM32L052x8 MCU
 - Integrated 50 MHz crystal
 - 64 KB flash
 - 8 KB RAM
 - TX output power up to +24 dBm
 - RX sensitivity: -128 dBm
- Power consumption
 - 18 mA RX
 - 210 mA TX peak current @22 dBm on Sigfox message transmission
 - Max. of 26 dBm TX peak output power on Sigfox message transmission
- RF
 - S2-LP Transceiver STMicroelectronics
 - SKY66420-11 Front-End Module
 - Frequency bands:
 - 413-479 MHz
 - 452-527 MHz
 - 826-958 MHz
 - 904-1055 MHz
 - Modulation schemes:
 - DBPSK, 2(G)FSK, OOK, ASK
 - Sigfox data rate, up to region:
 - 100bps or 600bps

INTERFACES

- Up 21 General-Purpose Input/Output (GPIO) pins, with configurable pull-up/pull-down resistors
- 12-bit ADC
- 12-bit 1 channel DAC
- 2 USART, LPUART, USB 2.0, I2C
- Single power supply: 2.7 V to 3.6 V
- Operating temperature range: -40°C to +85°C
- External antenna
- 13x13x1.1mm LGA – 32 pads package
- Part number: HTSXMO32L-22

APPLICATIONS

- Smart home
- Wireless alarm systems
- Manufacturing
- Agriculture
- Building automation
- Smart metering
- Smart lighting systems
- Smart grid monitoring

SUMMARY

OVERVIEW.....	2
SUMMARY.....	3
DOCUMENT INFO.....	3
1 BLOCK DIAGRAM.....	4
2 PINOUT INFORMATION.....	4
2.1 PIN DIAGRAM.....	4
2.2 PIN DESCRIPTION.....	5
3 ELECTRICAL CHARACTERISTICS.....	7
3.1 GENERAL OPERATING RANGE.....	7
3.2 MCU I/O PORT CHARACTERISTICS.....	7
3.3 POWER CONSUMPTION.....	8
3.4 INTERNAL CRYSTAL OSCILLATOR.....	9
3.5 EXTERNAL CLOCK RESONATOR.....	9
4 RF CHARACTERISTICS.....	9
4.1 SIGFOX OUTPUT POWER BY RCZ.....	10
4.2 EXTERNAL IMPEDANCE MATCHING NETWORK.....	10
5 PACKAGE OUTLINE.....	11
6 RECOMMENDED PCB FOOTPRINT.....	12
7 PART NUMBER.....	12
8 PACKING AND ORDERING INFORMATION.....	13
9 STORAGE AND HANDLING.....	14
10 SOLDERING INFORMATION.....	14
DISCLAIMER.....	15
ABBREVIATIONS.....	16
LIST OF FIGURES.....	17
LIST OF TABLES.....	17
REVISION HISTORY.....	18
CONTACT.....	18
DOCUMENT INFORMATION.....	18

DOCUMENT INFO

This document provides information about iMCP HT32SX – Sigfox® Monarch RF Transceiver System-in-Package. Make sure you have the most up-to-date information about this product at <https://github.com/htmicron/ht32sx>.

1 BLOCK DIAGRAM

Functional description.

FIGURE 1: BLOCK DIAGRAM

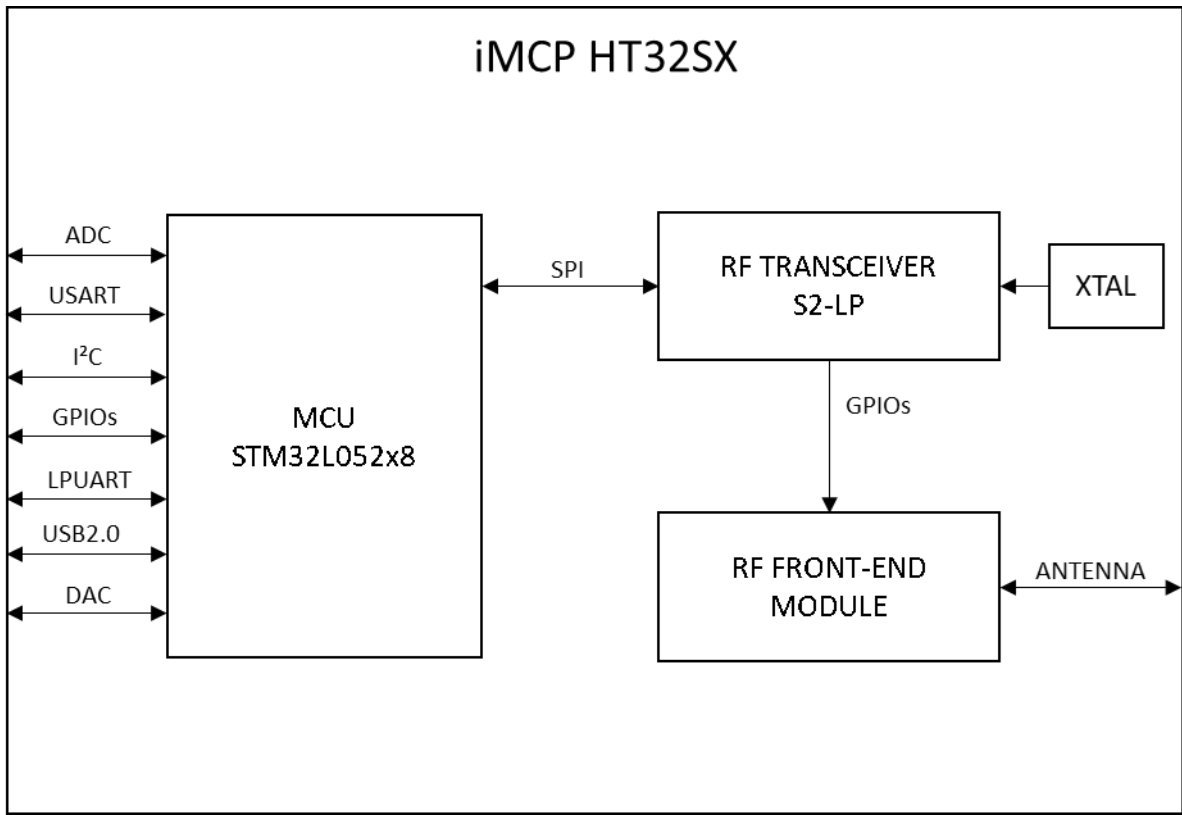

2 PINOUT INFORMATION

2.1 Pin Diagram

FIGURE 2: PIN DIAGRAM

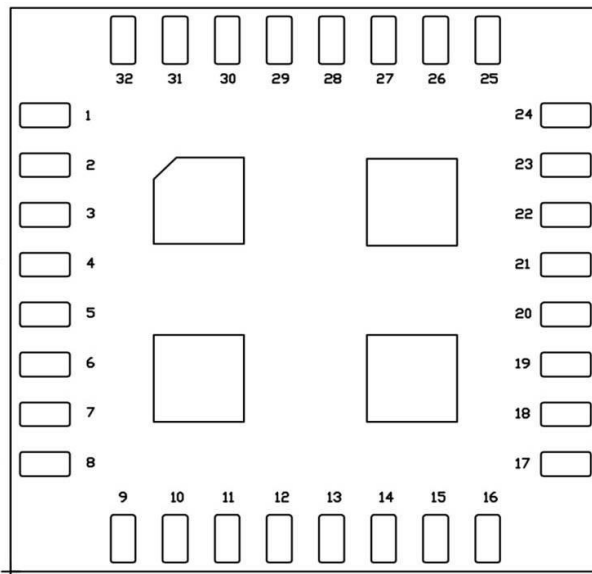

2.2 Pin description

TABLE 1: LEGEND/ABBREVIATIONS USED IN PIN DESCRIPTION TABLE

Name	Abbreviation	Definition
I/O Structure	FT	5V tolerant I/O
	FTf	5V tolerant I/O, FM+ capable
	TC	Standard 3.3V I/O
	B	Dedicated BOOT0 pin
	RST	Bidirectional reset pin with embedded weak pull-up resistor

TABLE 2: PIN DESCRIPTION

Number	Symbol	Pin name	Pin Type	I/O Structure	Description
1	ANTENNA	ANTENNA	RF I/O	-	RF input and output signal
2	GND	GND	Ground	-	Exposed pad connected to the ground of the application board
3	MCU-PA11	USART1_CTS	Digital I/O	FT	USART interface
		USB_DM	Digital I/O		USB
		COMP1_OUT	Analog O		Comparator output
		EVENT_OUT	Digital I/O		
4	MCU-PA9	USART1_TX	Digital I/O	FT	Serial wire
5	MCU-PA10	USART1_RX	Digital I/O	FT	
6	MCU-PB11	LPUART1_RX	Digital I/O	FT	Low-power USART interface
		TIM2_CH4	Digital I/O		General-purpose timer
		EVENTOUT	Digital I/O		
7	MCU-PB0	ADC_IN8	Analog I	FT	ADC external input 8
		VREF_OUT	Analog I/O		Output reference voltage
8	VDD_3.3V	VDD_3.3V	Power	-	3.3 V power supply
9	MCU-PA8	USART1_CK	Digital I/O	FT	USART interface
		USB_CSR_SYNC	Digital I/O		USB
		EVENT_OUT	Digital I/O		
10	MCU-PA5	ADC_IN5	Analog I	TC	ADC external input 5
		TIM2_CH1	Digital I/O		General-purpose timer
		TIM2_ETR	Digital I/O		General-purpose timer
		COMP1_INM5	Analog I		Comparator input
11	MCU-PA3	USART2_RX	Digital I/O	FT	USART interface
		ADC_IN3	Analog I		ADC external input 3
		TIM2_CH4	Digital I/O		General-purpose timer
		TIM21_CH2	Digital I/O		General-purpose timer
12	MCU-PA1	USART2_RTS_DE	Digital I/O	FT	USART interface
		ADC_IN1	Analog I		ADC external input 1
		COMP1_INP	Analog I		Comparator input
		TIM21_ETR	Digital I/O		General-purpose timer
		EVENT_OUT	Digital I/O		
13	MCU-PB10	LPUART1_TX	Digital I/O	FT	USART interface
		TIM2_CH3	Digital I/O		General-purpose timer
14	MCU-PA6	LPUART1_CTS	Digital I/O	FT	USART interface
		ADC_IN6	Analog I		ADC external input 6
		TIM22_CH1	Digital I/O		General-purpose timer
		COMP1_OUT	Analog O		Comparator output
		EVENT_OUT	Digital I/O		

15	MCU-PA4	USART2_CK	Digital I/O	TC	USART interface
		ADC_IN4	Analog I		ADC external input 4
		DAC_OUT	Analog O		DAC analog output
		TIM22_ETR	Digital I/O		General-purpose timer
		COMP1_INM4	Analog I		Comparator input
16	GND	GND	Ground	-	Exposed pad connected to the ground of the application board
17	MCU-PA2	USART2_TX	Digital I/O	FT	USART interface
		ADC_IN2	Analog I		ADC external input 2
		TIM21_CH1	Digital I/O		General-purpose timer
		TIM2_CH3	Digital I/O		General-purpose timer
18	MCU-PA0	WKUP1	Digital I	TC	MCU external wakeup input
		ADC_IN0	Analog I		ADC external input 0
		USART2_CTS	Digital I/O		USART interface
		TIM2_CH1	Digital I/O		General-purpose timer
19	MCU-BOOT0	BOOT0	Digital I	B	Boot selection
20	MCU-PB5	I2C1_SMBA	Digital I/O	FT	I2C interface
		LPTIM1_IN1	Digital I/O		Low-power timer
		TIM22_CH2	Digital I/O		General-purpose timer
21	GND	GND	Ground	-	Exposed pad connected to the ground of the application board
22	NRESET	NRESET	I/O	RST	Bidirectional reset pin with embedded weak pull-up resistor
23	MCU-PA14	SWCLK	Digital O	FT	Serial wire clock output
		USART2_TX	Digital I/O		USART interface
24	MCU-PA13	SWDIO	Digital I/O	FT	Serial wire
		USB_NOE	Digital I/O		USB
25	MCU-PC15	OSC32OUT	Ext. clock	TC	External clock source pins
		GPIO	Digital I/O		General purpose I/O
26	MCU-PC14	OSC32IN	Ext. clock	FT	External clock source pins
		GPIO	Digital I/O		General purpose I/O
27	GND	GND	Ground	-	Exposed pad connected to the ground of the application board
28	MCU-PB1	LPUART1_RTS_DE	Digital I/O	FT	Low-power USART interface
		ADC_IN9	Analog I		ADC external input 9
		VREF_OUT	Analog O		1.2 V VCO-LDO band-gap reference voltage decoupling
29	MCU-PB7	USART1_RX	Digital I/O	FTf	USART interface
		I2C1_SDA	Digital I/O		I2C interface
		LPTIM1_IN2	Digital I/O		Low-power timer
30	MCU-PB6	USART1_TX	Digital I/O	FTf	USART interface
		I2C1_SCL	Digital I/O		I2C interface
		LPTIM1_ETR	Digital I/O		Low-power timer
31	MCU-PA12	USART1_RTS_DE	Digital I/O	FT	USART interface
		USB_DP	Digital I/O		USB
		EVENT_OUT	Digital I/O		
32	GND	GND	Ground	-	Exposed pad connected to the ground of the application board

3 ELECTRICAL CHARACTERISTICS

3.1 General operating range

TABLE 3: GENERAL OPERATING RANGE

Parameter	Conditions	Min	Typ.	Max	Unit
Supply voltage	-	2.7	3.3	3.6	V
Operating temperature	-	-30	25	85	°C
Storage temperature	Refer to section 9				

3.2 MCU I/O port characteristics

TABLE 4: MCU I/O PORT CHARACTERISTICS

Symbol	Parameter	Conditions	Min	Typ.	Max	Unit
V_{IL}	Input low level voltage	TCFT, FTf, RST I/Os	-	-	$0.3V_{DD}$	V
		BOOT0 pin	-	-	$0.14V_{DD}$	
V_{IH}	Input high level voltage	All I/Os	$0.7V_{DD}$	-	-	
V_{hys}	I/O Schmitt trigger voltage hysteresis	Standard I/Os	-	$10\% V_{DD}$	-	
		BOOT0 pin	-	0.01	-	
I_{lkg}	Input leakage current	$V_{SS} < V_{IN} < V_{DD}$ All I/Os except PA11, PA12, BOOT0, FTf I/Os	-	-	+50	
		$V_{SS} < V_{IN} < V_{DD}$ PA11 and PA12 I/Os	-	-	-50/+250	
		$V_{SS} < V_{IN} < V_{DD}$ FTf I/Os	-	-	+100	
		$V_{DD} < V_{IN} < 5V$ All I/Os except PA11, PA12, BOOT0, FTf I/Os	-	-	200	
		$V_{SS} < V_{IN} < 5V$ FTf I/Os	-	-	500	nA
		$V_{SS} < V_{IN} < 5V$ PA11, PA12, BOOT0	-	-	10	uA
R_{PU}	Weak pull-up equivalent resistor	$V_{IN} = V_{SS}$	25	45	65	k Ω
R_{PD}	Weak pull-down equivalent resistor	$V_{IN} = V_{DD}$	25	45	65	k Ω
C_{IO}	I/O pin capacitance	-	-	5	-	pF

TABLE 5: OUTPUT VOLTAGE CHARACTERISTICS

Symbol	Parameter	Conditions	Min	Max	Unit
V_{OL}	Output low level voltage for an I/O pin	CMOS port $I_{IO}=+8mA$ $2.7V < V_{DD} < 3.6V$	-	0.4	V
V_{OH}	Output high level voltage for an I/O pin		$V_{DD}-0.4$	-	
V_{OL}	Output low level voltage for an I/O pin	TTL port $I_{IO}=+8mA$ $2.7V < V_{DD} < 3.6V$	-	0.4	

V_{OH}	Output high level voltage for an I/O pin	TTL port $I_{IO} = -6\text{mA}$ $2.7\text{V} < V_{DD} < 3.6\text{V}$	2.4	-	
V_{OL}	Output low level voltage for an I/O pin	$I_{IO} = +15\text{mA}$ $2.7\text{V} < V_{DD} < 3.6\text{V}$	-	1.3	
V_{OH}	Output high level voltage for an I/O pin	$I_{IO} = -15\text{mA}$ $2.7\text{V} < V_{DD} < 3.6\text{V}$	$V_{DD} - 1.3$	-	
V_{OL}	Output low level voltage for an I/O pin	$I_{IO} = +4\text{mA}$ $2.7\text{V} < V_{DD} < 3.6\text{V}$	-	0.45	
V_{OH}	Output high level voltage for an I/O pin	$I_{IO} = -4\text{mA}$ $2.7\text{V} < V_{DD} < 3.6\text{V}$	$V_{DD} - 0.45$	-	
V_{OLFM+}	Output low level voltage for an FTf I/O pin in FM+ mode	$I_{IO} = +20\text{mA}$ $2.7\text{V} < V_{DD} < 3.6\text{V}$	-	0.4	
		$I_{IO} = 10\text{mA}$ $2.7\text{V} < V_{DD} < 3.6\text{V}$	-	0.4	

3.3 Power consumption

Characteristics measured over recommended operating conditions unless otherwise specified. Typical values are referred to 25 °C temperature, VDD = 3.3 V.

TABLE 6: LOW-POWER STATE POWER CONSUMPTION TA = 25 °C, VDD = 3.3 V.

Parameter	Conditions	Min	Typ.	Max	Unit
Supply current	Shutdown	-	-	-	nA
	Standby	1.3	1.33	1.4	mA
	Sleep	2.67	5.5	9.2	µA
	Deep sleep	2.5	3.5	8.4	µA

TABLE 7: POWER CONSUMPTION IN RECEPTION TA = 25 °C, VDD = 3.3 V, FC = 905 MHZ

Parameter	Conditions	Min	Typ.	Max	Unit
Supply current	RX @ -128 dBm sensitivity level for a Sigfox signal	-	18	-	mA

TABLE 8: POWER CONSUMPTION IN TRANSMISSION TA = 25 °C, VDD = 3.3 V, FC = 902.2 MHZ

Parameter	Conditions	PA	Min	Typ.	Max	Unit
Average supply current of a single Sigfox frame	TX @22 dBm	ON	148	170	190	mA
	TX @12 dBm	OFF	19.2	25	27	
Average supply current of a Sigfox message (total of 3 frames)	TX @26 dBm	ON	-	160	-	
	TX @22 dBm	ON	-	110	-	
	TX @12 dBm	OFF	-	21.5	-	
Peak supply current on Sigfox message transmission	TX @26 dBm	ON	-	-	313	
	TX @22 dBm	ON	-	-	210	
	TX @12 dBm	OFF	-	-	28.5	

3.4 Internal crystal oscillator

The integrated crystal oscillator is used as the frequency reference for the RF transceiver and its choice was based on the Sigfox requirements.

TABLE 9: 50 MHz INTERNAL XTAL CLOCK SOURCE CHARACTERISTICS

Parameter	Conditions	Min	Typ.	Max	Unit
Nominal frequency	-	-	50	-	MHz
Frequency tolerance	-20°C to 75 °C	-10	-	+10	ppm

3.5 External clock resonator

The external clock resonator can be of high speed (1-25MHz) or low speed (32.768kHz), which can be connected to pins 25 and 26 of the iMCP HT32SX V2.2. The connection diagram is shown below. For CL1 and CL2, it is recommended to use high quality ceramic capacitors in the 5pF to 25 pF range (typ.), designed for high frequency applications, and selected to match the requirements of the crystal or resonator. These capacitors are usually of equal value with a rough estimate of 10 pF each. CL1 and CL2 includes PCB and the MCU pin capacitances.

FIGURE 3: EXTERNAL OSCILLATOR CIRCUIT DIAGRAM.

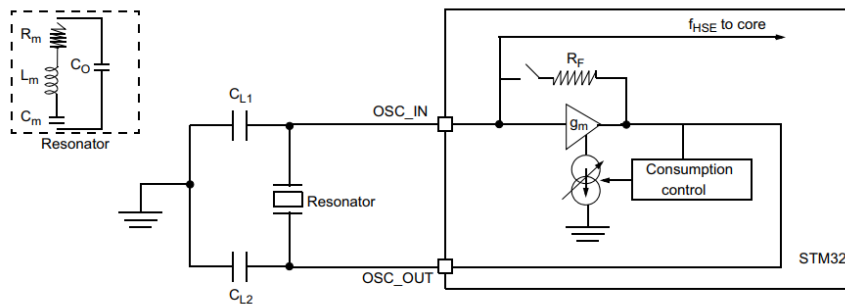

4 RF CHARACTERISTICS

TABLE 10: TRANSCEIVER AND RECEIVER CHARACTERISTICS. TA = 25°C BASED ON CHARACTERIZATION; NOT TESTED IN PRODUCTION. VDD = 3.3V; ALL RX MEASUREMENTS MADE AT THE ANTENNA CONNECTOR, TO A BIT ERROR RATE (BER) LIMIT OF 1%.

Parameter		Min	Typ.	Max	Unit
RF Frequency	TX	865	-	924	MHz
	RX	869	-	923	MHz
Tx max. output power for the Sigfox signal		-	24	-	dBm
Emission 2 nd Harmonic (conducted) @max power		-40.4	-47.3	-39.9	dBc
Emission 3 rd Harmonic (conducted) @max power		-50.5	-76.2	-55.0	
Emission 4 th harmonic (conducted) @max power		-78.9	-78.6	-70.0	
Data Rate (for Sigfox Regions)	TX (RC1, RC3, RC5, RC6, RC7)	-	100	-	bps
	TX (RC2, RC4)	-	600	-	bps
	RX (All RCs)	-	600	-	bps
Antenna Load Impedance			50		Ohm

Rx Sensitivity (@600bps, GFSK)		-128		dBm
Rx Spurious Emission (30MHZ~12.75GHZ)	-	-	-	dBm
Rx Blocking at 10MHz offset	-	-	-	dB
RSSI Resolution	-	-	-	dB

4.1 Sigfox output power by RCZ

Table 11 shows the output power used during the Sigfox homologation:

TABLE 11: SIGFOX OUTPUT POWER

RCZ	Output power (dBm)
RC1	10.9
RC2	22.5
RC3	11.0
RC4	22.5
RC5	11.0
RC6	11.0
RC7	10.9

4.2 External impedance matching network

An external LC matching network is recommended to improve the output power level of the output signal in pin 1 (series inductor and shunt capacitor). The reference specifications for a reference FR4 1.6 mm 1 Oz copper printed circuit board (PCB) are shown below.

- SMD ceramic inductor: 5.6 nH, +-5% tolerance, 0402 size, PN L-07C5N6SV6, Johanson Technologies
- SMD ceramic capacitor: 4.7 pF, +-0.1pF tolerance, 0201 size, PN 250R05L4R7BV4S, Johanson Technologies

The reference PCB traces are shown in Figure 4 for an example of an output using an SMA connector. The trace width are the same as the pad width in the recommended footprint in section 6.

FIGURE 4: RECOMMENDED EXTERNAL LC MATCHING NETWORK LAYOUT.

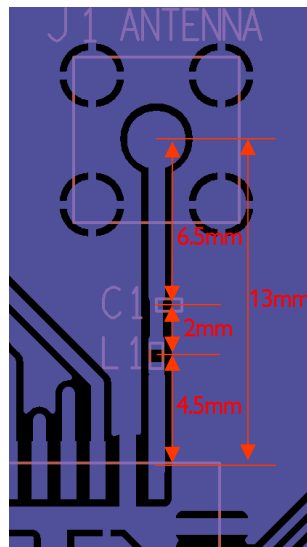

5 PACKAGE OUTLINE

FIGURE 5: PACKAGE OUTLINE

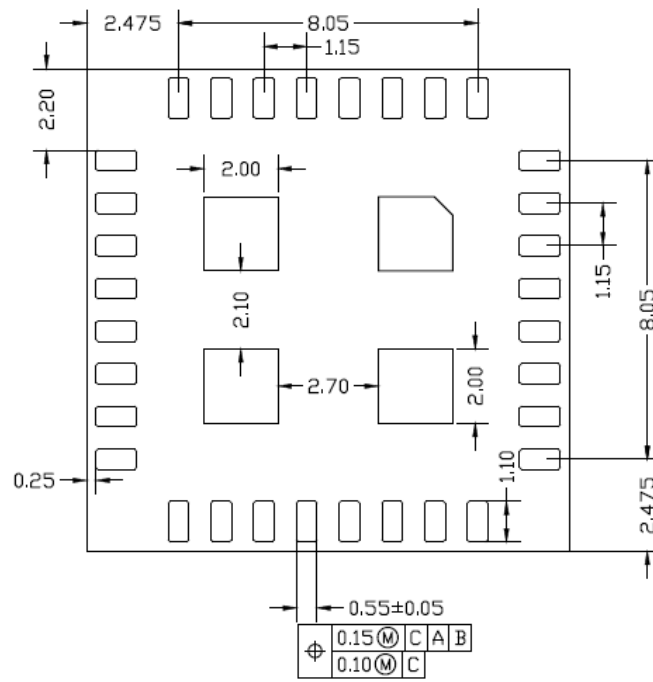

BOTTOM VIEW

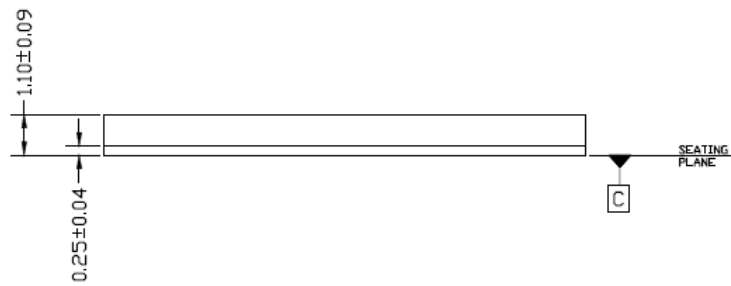

SIDE VIEW

6 RECOMMENDED PCB FOOTPRINT

FIGURE 6: RECOMMENDED PCB FOOTPRINT

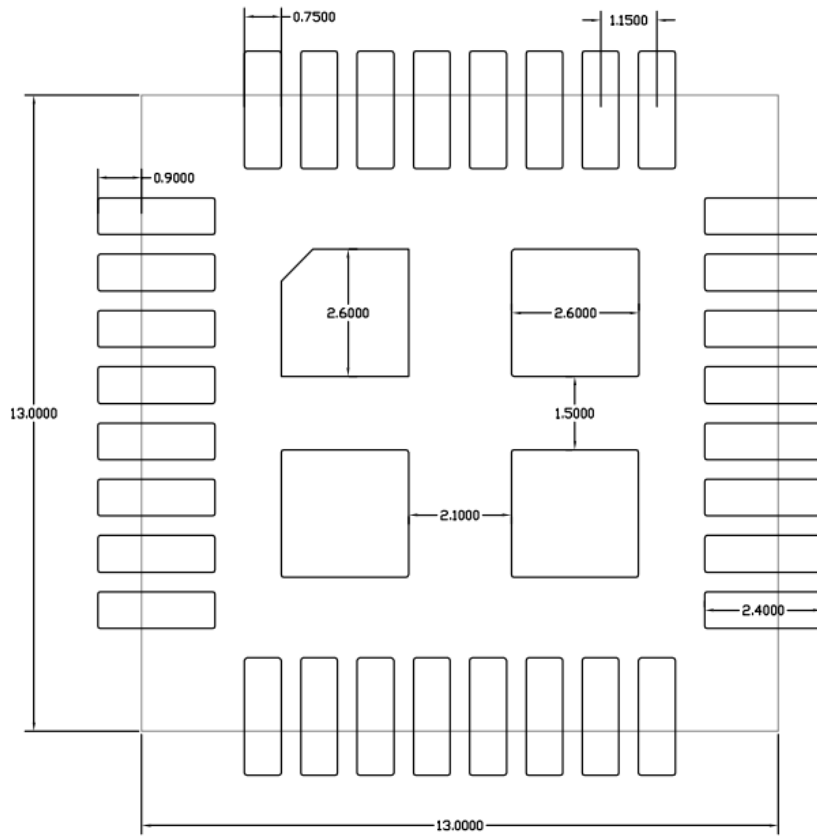

7 PART NUMBER

HT	SX	MO	32	L	-	22
HT Micron						Version
Family						22: Ver. 2.2
SX: Sigfox						Package
Technology						L: LGA
MO: Monarch						Lead Count
						32

8 PACKING AND ORDERING INFORMATION

TABLE 11: ORDERING INFORMATION

Part number	Package		
	Name	Description	Version
HTSXMO32L-22	iMCP HT32SX	SiP module in LGA package; body 13mm x 13mm	2.2

Products sold directly by HT Micron will be delivered in bagged trays, sealed in moisture resistant bags with desiccant pack and humidity cards. Trays are suitable for baking temperatures. Samples provided by HT Micron may be delivered in other packing methods. Please, refer to section 9 for storage, handling and moisture sensitivity information.

FIGURE 7: TRAY SIZES

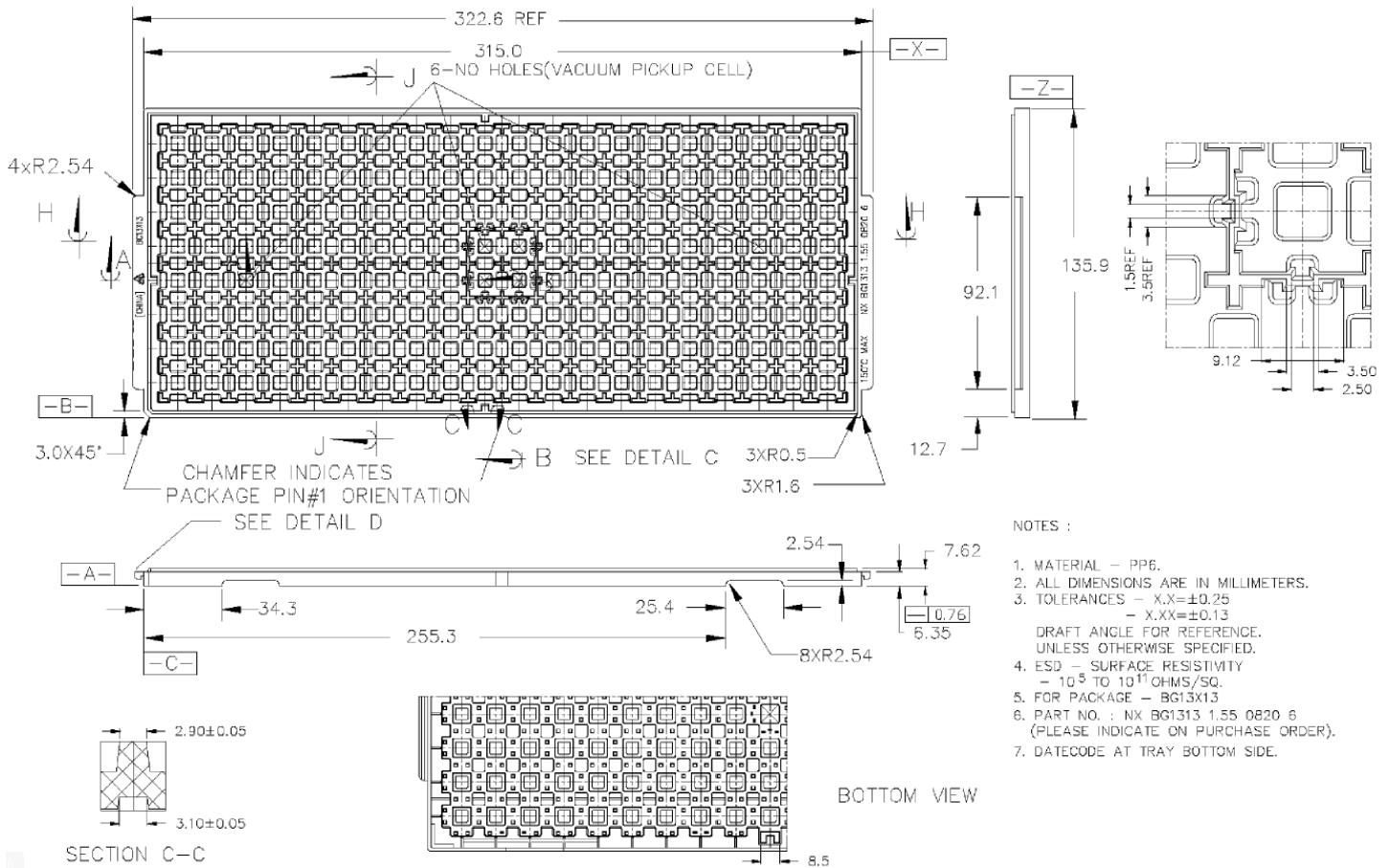

9 STORAGE AND HANDLING



CAUTION

ELECTROSTATIC and MOISTURE
SENSITIVE DEVICE



LEVEL 3

- Baking for 24 hours at $125 \pm 5^\circ\text{C}$ is strongly recommended prior to mounting.
- Take proper precautions to avoid high-energy electrostatic discharge (ESD) as permanent damage may occur.
- For handling methods refer to the latest ESD Association standard ANSI/ESD S20.20.
- Do not expose the device to corrosive gasses, extreme humidity, extensive direct sunlight.
- The device is susceptible to delamination or crack damage induced by absorbed moisture and high temperature.
- Shelf life in sealed bagged tray: 12 months at $\leq 40^\circ\text{C}$ and $\leq 90\%$ relative humidity (RH).
- This device is rated MSL 3.
- For bagged tray lots: after the bag is opened, the humidity card must read $\leq 20\%$ (at $23 \pm 5^\circ\text{C}$), and the devices must be mounted within 168 hours at environmental conditions of $\leq 30^\circ\text{C}$, $\leq 60\%$ RH.
- If the above condition is not met, baking for 24 hours at $125 \pm 5^\circ\text{C}$ is mandatory prior to mounting.
- For moisture sensitivity devices precaution methods refer to the latest standard IPC/JEDEC-J-STD-033.
- For any other packing method: baking is required for 192 hours at 40°C prior to mounting.
- This device is composed of all RoHS compliant materials. Refer to the Figure 8 for typical Pb-Free reflow conditions.
- Hand soldering is not recommended for this device.
- For moisture sensitivity classification and soldering methods, refer to the latest standard IPC/JEDEC-J-STD-020.
- Do not drop, shock or apply mechanical stress.

10 SOLDERING INFORMATION

Soldering conditions depend greatly on the solder paste that is used and as such are application specific. The picture below depicts typical Pb-free soldering conditions as seen in IPC/JEDEC-J-STD-020 standard, which are commonly used in the industry. However, ultimately, we recommend that the instructions of the solder supplier are followed.

FIGURE 8: TYPICAL PB-FREE REFLOW CONDITIONS (IPC/JEDEC-J-STD-020)

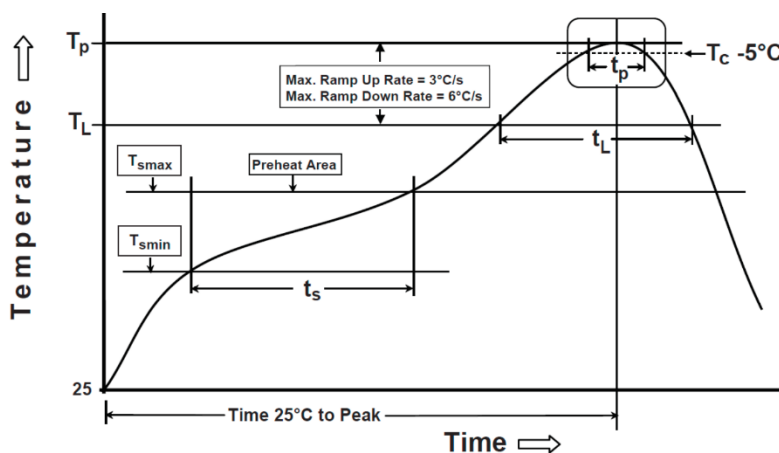

- Min preheat temperature (T_{smin}): 150°C
- Max preheat temperature (T_{smax}): 200°C
- Preheat (soaking) time (T_s): 60 to 120 s
- Liquidous temperature (T_L): 217°C
- Peak temperature (T_p): 260°C
- Max ramp-up rate (T_L to T_p): 3°C/s
- Time above T_L (t_L): 60 to 150 s
- Classification temperature (T_c): 260°C
- Time above $T_c - 5^\circ\text{C}$ (t_p): 30 s
- Max ramp-down rate (T_p to T_L): 6°C/s
- Max time 25°C to T_p : 8 minutes

DISCLAIMER

This document is a property of HT Micron and cannot be reproduced without its consent. Information herein contained are for informational purposes only and HT Micron assumes no responsibility for errors or omissions in this document. HT Micron documents, products, product specifications and descriptions may change without notice, at any time. Purchasers should obtain the latest relevant information on HT Micron products before placing orders.

HT Micron assumes no liability for customer product applications, design or damage to any equipment resulting from the use of HT Micron products outside of specifications and parameters.

No license of any patent, copyright or any other intellectual property right is granted by this document, whether by implication, estoppel or otherwise. HT Micron assumes no liability for any materials, products or information provided in this document except as may be provided in Terms and Conditions of Sale for customers purchasing directly from HT Micron.

Products, specifications and information are provided on an “as is” basis for reference purposes only and without warranties of any kind. HT Micron does not warrant the accuracy or completeness of information contained in this document.

HT Micron products are not intended for use in life support, medical care, safety equipment, or any other application in which product failure could lead to loss of life, personal injury, physical or environmental damage.

ABBREVIATIONS

TABLE 12: ABBREVIATIONS

Acronym	Description
ADC	Analog to Digital Converter
AES	Advanced Encryption Standard
API	Application Program Interface
CLK	Clock
EEPROM	Electrically-Erasable Programmable Read Only Memory
FIFO	First in First Out
GPIO	General Purpose Input Output
ID	Identification
IF	Intermediate frequency
IO	Input Output
MSL	Moisture sensitivity level
PCB	Printed-Circuit Board
PHY	Physical
SPI-bus	Serial Peripheral Interface -bus
PWM	Pulse Width Modulation
RAM	Random Access Memory
RC	Remote Control
RF	Radio Frequency
RoHS	Restriction of Hazardous Substances
RSSI	Receive Signal Strength Indication
RX	Receiver
SCL	Serial Clock
SDA	Serial Data
TX	Transmitter

LIST OF FIGURES

Figure 1: Block Diagram.....	4
Figure 2: Pin Diagram.....	4
Figure 3: External oscillator circuit diagram.....	9
Figure 4: recommended external LC matching network layout.....	10
Figure 5: Package Outline.....	11
Figure 6: Recommended PCB Footprint.....	12
Figure 7: Tray sizes.....	13
Figure 8: Typical Pb-Free reflow conditions (IPC/JEDEC-J-STD-020).....	14

LIST OF TABLES

Table 1: Legend/abbreviations used in pin description table.....	5
Table 2: Pin description.....	5
Table 3: General Operating Range.....	7
Table 4: MCU I/O port characteristics.....	7
Table 5: Output voltage characteristics.....	7
Table 6: Low-power state power consumption TA = 25 °C, VDD = 3.3 V.....	8
Table 7: Power consumption in reception TA = 25 °C, VDD = 3.3 V, fc = 905 MHz.....	8
Table 8: Power consumption in transmission TA = 25 °C, VDD = 3.3 V, fc = 902.2 MHz.....	8
Table 9: 50 MHz Internal XTAL clock source characteristics.....	9
Table 10: Transceiver and Receiver characteristics. TA = 25°C based on characterization; not tested in production. VDD = 3.3V; All RX measurements made at the antenna connector, to a bit error rate (BER) limit of 1%.....	9
Table 11: Ordering information.....	13
Table 12: Abbreviations.....	16

REVISION HISTORY

Date	Version	Changes	Remark
13/04/2020	00	- Initial draft	
05/08/2020	01	- Preliminary	
20/11/2020	02	- Preliminary - fixed power consumption information	
25/01/2021	03	- Fixed ADC_IN8 (PB0) on PIN7, operating temperature range update	
19/02/2021	04	- Package height; packing; storage, handling and soldering; disclaimer	
24/03/2021	05	- Current supply updates.	
14/12/2021	06	- Preliminary mark removed.	
11/02/2022	07	-Device temperature range, Handling and Storage section and datasheet web link reference updated	
14/09/2022	08	- Added Sigfox output power by RCZ.	

CONTACT

HT MICRON SEMICONDUTORES S.A.
 Av. Unisinos, 1550 | 93022-750 | São Leopoldo | RS | Brasil
www.htmicron.com.br

DOCUMENT INFORMATION

Document Title: iMCP HT32SX V2.2 – SiP Sigfox
 Document Subtitle: Sigfox® Monarch RF Transceiver System-in-Package
 Classification: Public
 Doc. Type: DATASHEET
 Revision: Rev. 08
 Date: 14/09/2022
 Code: DS001
 Internal Doc Reference: FO440 - rev.01 Data: 12/08/2020 Doc. Ref.: PR001