

## SUMMARY

### # Wires

Low voltage 5



*Image is for illustrative purpose only*

Series	0F
Termination type	Female print PCB
IP rating	68 mated (mating interface)
AWG wire size	30.00 - 22.00
Cable Ø	0.00 - 0.00 mm
Status	Active
Matching parts	<a href="#">FGN.0F.305.XLC</a>

### Download

- [Request a quote](#)
- [PCB Eagle Pattern](#)
- [PCB Altium Pattern](#)
- [PCB KiCad Pattern](#)
- [Catalog](#)

## TECHNICAL DETAILS

### Mechanics

Shell Style/Model	HE*: Fixed receptacle, nut fixing, for printed circuit (back panel mounting)
Keying	3 keys (beta=165, gamma=30, plug: male contacts, receptacle: female contacts)
Housing Material	Aluminium (nickel plated [SAE AMS QQ N 290], anthracite color) shell and nut, other pieces bronze/brass
Variant	P : Watertight unmated (connector to device)
Weight	3.33 g

### Performance

Configuration	0F.305 : 5 Low Voltage
Insulator	L: PEEK (UL 94 / V-0/1.5)
Rated Current	6.5 Amps

### Specifications

Contact Type: Print (straight)  
Contact Dia.: 0.7 mm (0.028in)  
R (max): 6.1 mOhm  
Vtest (contact-shell): 1200 V (AC), 1700 V (DC)  
Vtest (contact-contact): 1250 V (AC), 1770 V (DC)

*LEMO products and services are provided "as is". LEMO makes no warranties or representations with regard to LEMO product & services or use of them, express, implied or statutory, including for accuracy, completeness, or security. The user is fully responsible for his products and applications using LEMO components.*

## Others

Endurance (Shell): 1000 mating cycles  
Temp (min / max): -15°C / +100°C  
Humidity (max): <=95% [at 60 deg C / 140 F]  
Vibration: 15 g [10 Hz - 2000 Hz]  
Shock Resistance: 100 g [ 6 ms]  
Climatical Category: 15/200/21 (Aluminium shell)  
Salt Spray Corrosion: max. 48 hr  
Pressure: 5 bars

## DRAWINGS

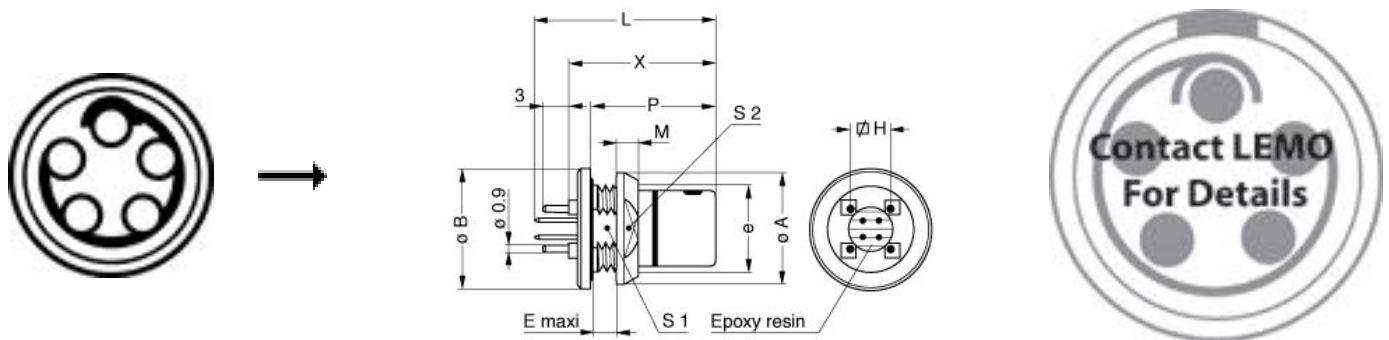

## Dimensions

	A	B	E	H	L	M	P	S1	S2	X	e
mm.	13	14	3	5.08	21.5	2.5	14.5	9	11	17.5	M10x0.75
in.	0,51	0,55	0,12	0,20	0,85	0,10	0,57	0,35	0,43	0,69	

## RECOMMENDED BY LEMO

## Tools

LEMO products and services are provided "as is". LEMO makes no warranties or representations with regard to LEMO product & services or use of them, express, implied or statutory, including for accuracy, completeness, or security. The user is fully responsible for his products and applications using LEMO components.

*LEMO products and services are provided "as is". LEMO makes no warranties or representations with regard to LEMO product & services or use of them, express, implied or statutory, including for accuracy, completeness, or security. The user is fully responsible for his products and applications using LEMO components.*