

Key Features

- Gap Tooth Speed Sensing in many applications
- Senses broad range of ferrous target sizes
- Senses broad frequency range up to 1^2 kHz
- Gap sensing capability up to 3mm
- Full output down to zero Hz
- Provides digital pulse output signal
- Compatible with speed switches, tachometers, counters, signal conditioners & PLCs
- Rugged, NEMA 4 sensor housing

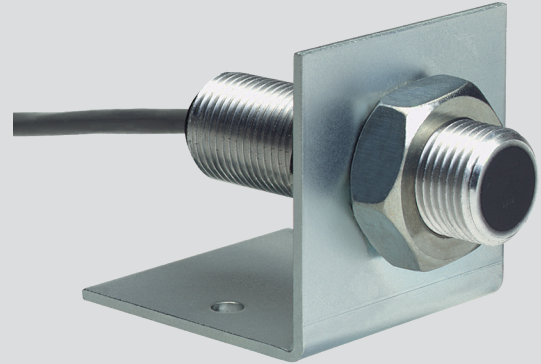

Description

HE950 Proximity Sensors produce digital pulse signals for use with speed switches, tachometers, counters, signal conditioners, or as a direct pulse input into programmable controllers (PLCs). The sensor incorporates a dual Hall-Effect sensor and signal processing that switches in response to differential magnetic signals created by a ferrous target. Typical targets are gear teeth, keyways, or bolt heads, and the circuitry achieves true zero-speed operation down to zero Hz. Each sensor is entirely solid state with no moving parts to wear out, providing a low maintenance rugged and long-lasting sensor. The HE950 Sensor has flexible gap sensing capability, enabling gap distances of up to 3mm with the proper target configuration.

HE950 Sensors are powered by 5-24 VDC, provide an NPN open collector output and can be mounted up to 1500 feet from the control unit (i.e. speed switch, tachometer or PLC). The standard HE950 Sensor has a threaded aluminum, NEMA 4 housing and is supplied with an adjustable, plated-steel mounting bracket and 10 feet of 3-conductor shielded cable.

Installation

The HE950 sensor is supplied with a plated steel mounting bracket and two jam nuts for easy gap distance adjustment. Sensors should be installed allowing the centerline of the gear teeth (or other ferrous target) to pass in front of the center of the sensor as the target rotates.

The recommended gap distance between the sensor and ferrous target is 2mm to 3mm. In order to achieve the proper gap distance, adjust the jam nuts securing the sensor in the mounting bracket.

Typical Installation

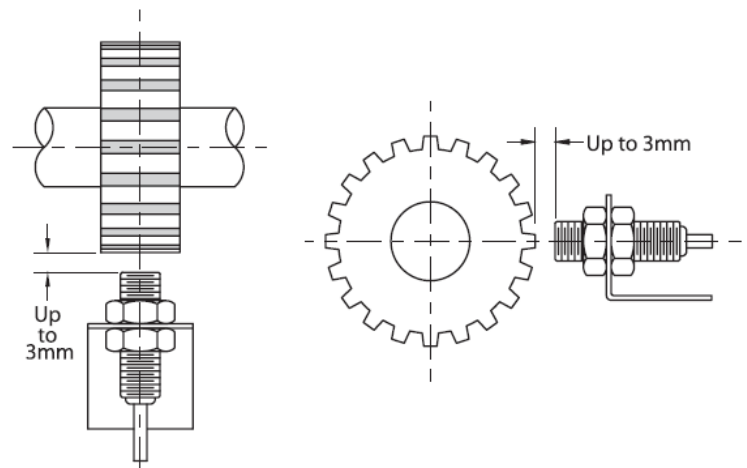

Operation: Air Gap/Tooth Geometry

Operating specifications are impacted by tooth size, valley size and depth, gear material, and gear thickness. In general, the following guidelines should be observed to achieve greater than 2mm gap distance between the face of the sensor and the target:

- Tooth width > 2mm
- Valley width > 2mm
- Valley depth > 2mm
- Gear thickness > 3mm
- Gear material must be low carbon steel

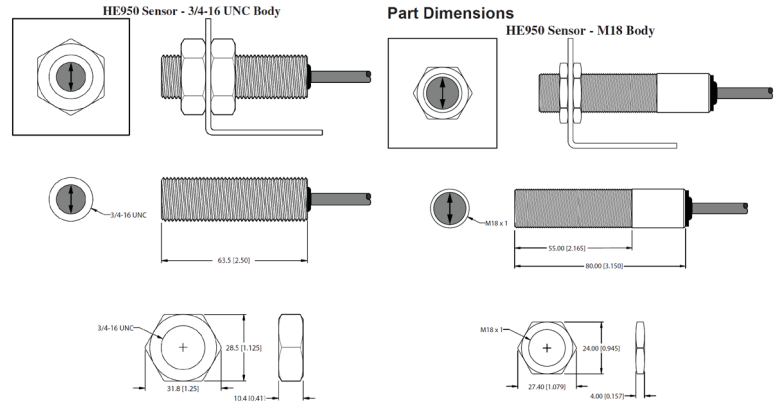

Electrical Connections • HE950 Sensor

The HE⁹⁵⁰ Sensor is designed for use with devices that have an internal pull-up resistor. If the device receiving the signal from the sensor does not have a pull-up resistor, a 2.2 KOhm resistor must be placed between the sensor supply voltage and the sensor signal output.

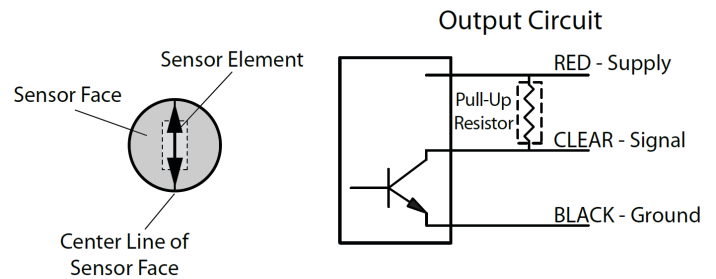

Note: Depending on the supply voltage, observe proper wattage rating of the pull-up resistor.

HE950 Gap Tooth Sensor

Product	
Supply	5-24 Vdc, 26 Vdc absolute maximum
Supply Current	15 mA maximum
Output Type	NPN Open Collector
Output Current	20 mA at 26 Vdc maximum
Maximum Frequency	12 kHz
Operating Temperature	-40° C to +60° C
Gap Distance	2mm to 3mm
Distance to Input Device	1,500 feet maximum
Cable (22AWG)	3-conductor shielded
Threads	3/4"-16 UNF threads & 18 mm

Ordering

HE950 sensors come with a standard bracket for mounting

Model	Part Number
HE950, w/ 10ft. Cable & Bracket (3/4 in thread)	775-001400
HE950-18, w/ 10ft. Cable & Bracket (18mm thread)	775-001410
HE950, w/ 50ft. Cable & Bracket (3/4 in thread)	775-001401
HE950, w/ 100ft. Cable & Bracket (3/4 in thread)	775-001402
HE950, w/ (High Temp) 10ft. Cable & Bracket (3/4 in thread)	775-001403

Specifications subject to change without notice.

Customization

If one of our standard products does not meet your specifications, please call one of our applications specialists. Many of our products can be customized to fit specific needs.

Additional Information

See the HE950 Gear Tooth Sensor Installation and Operating Manual for complete details, specifications, and install instructions.