

## SPECIFICATION

- Part No. : **GP.1575.35.3.A.02**
- Product Name : 3.5mm thick GPS Patch Antenna, 1575MHz
- Features : 35mm\*35mm\*3.5mm  
ROHS Compliant



## 1. Introduction

This 35\*35mm ceramic GPS/GALILEO patch antenna is based on smart *XtremeGain*™ technology. It is mounted via pin and double-sided adhesive and has been tuned as the optimal solution for the customer device environment.

## 2. Key Antenna Performance Indicators

Original Patch Specification tested on 50\*50mm ground plane

No	Parameter	Specification
1	Center Frequency	1575MHz ± 6MHz
2	Bandwidth	22MHz min
3	VSWR	1.5 max
4	Gain at Zenith	2.0 dBic typ.
5	Gain at 10°elevation	1.5dBic typ.
6	Axial Ratio	3 dB max
7	Polarization	RHCP
8	Impedance	50 Ohms
9	Frequency Temperature Coefficient ( $\tau_f$ )	0 ± 20ppm / °C
10	Operating Temperature	-40°C to +85°C

### 3. Test Setup

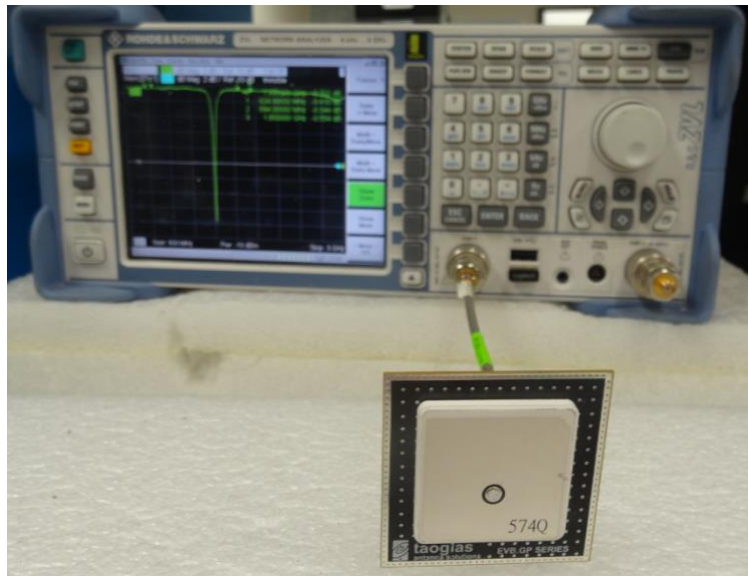

**Figure 1.** Return Loss measurement.

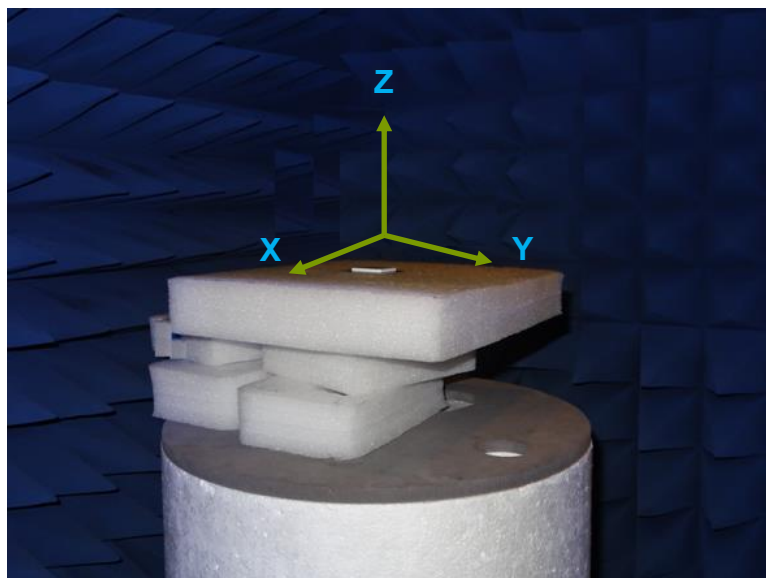

**Figure 2.** Peak gain, average gain, efficiency and radiation pattern measurements.

## 4. Antenna Parameters

### 4.1. Return Loss

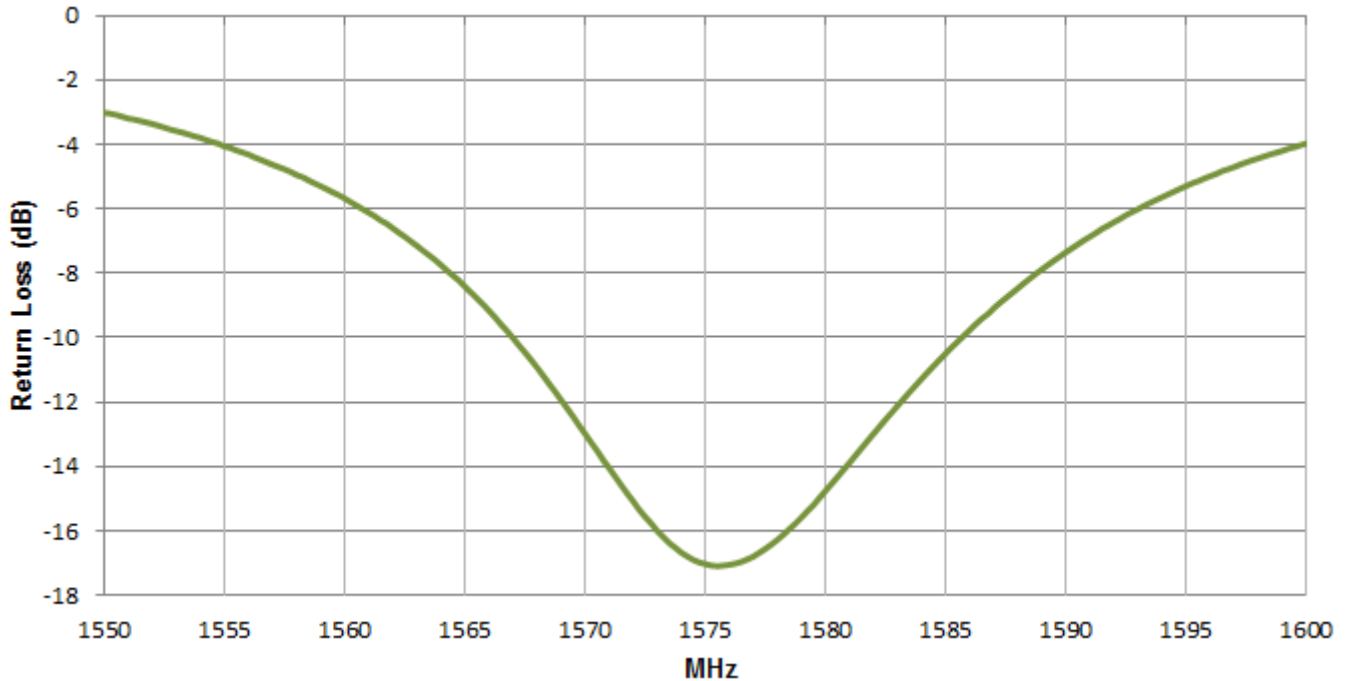

**Figure 3.** Return Loss of the GP.1575.35.A.02

### 4.2. VSWR

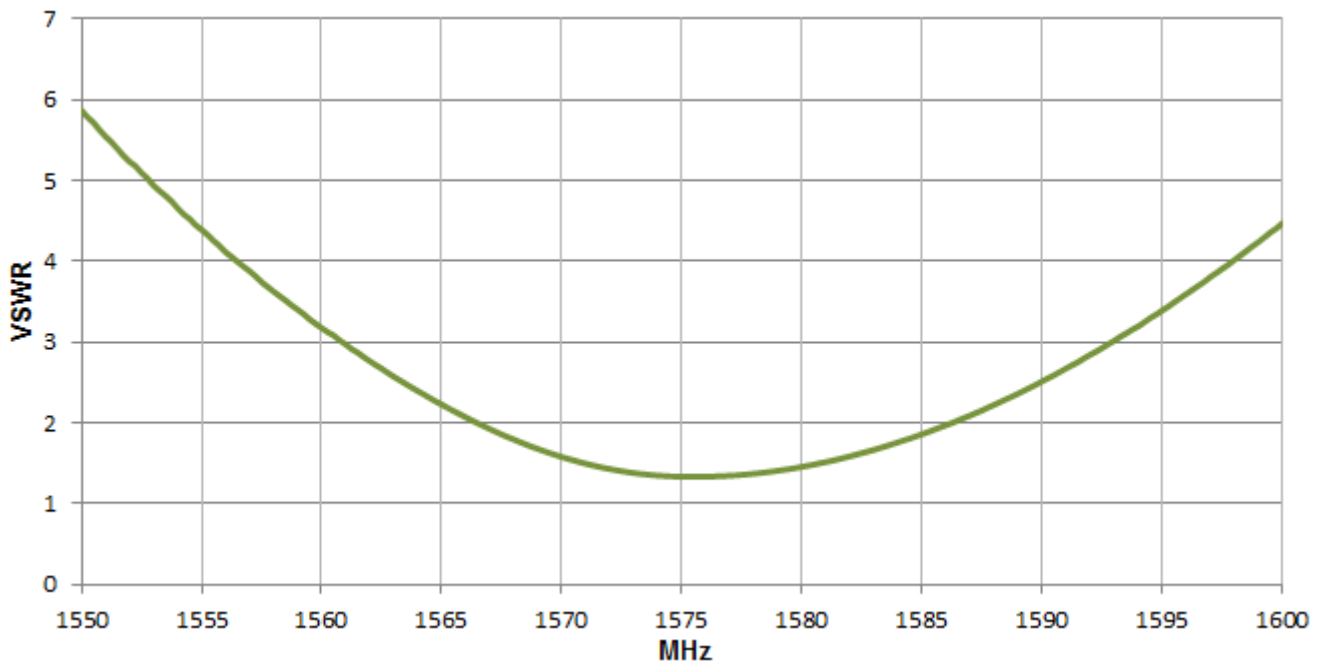

**Figure 4.** VSWR of the GP.1575.35.A.02

### 4.3. Efficiency

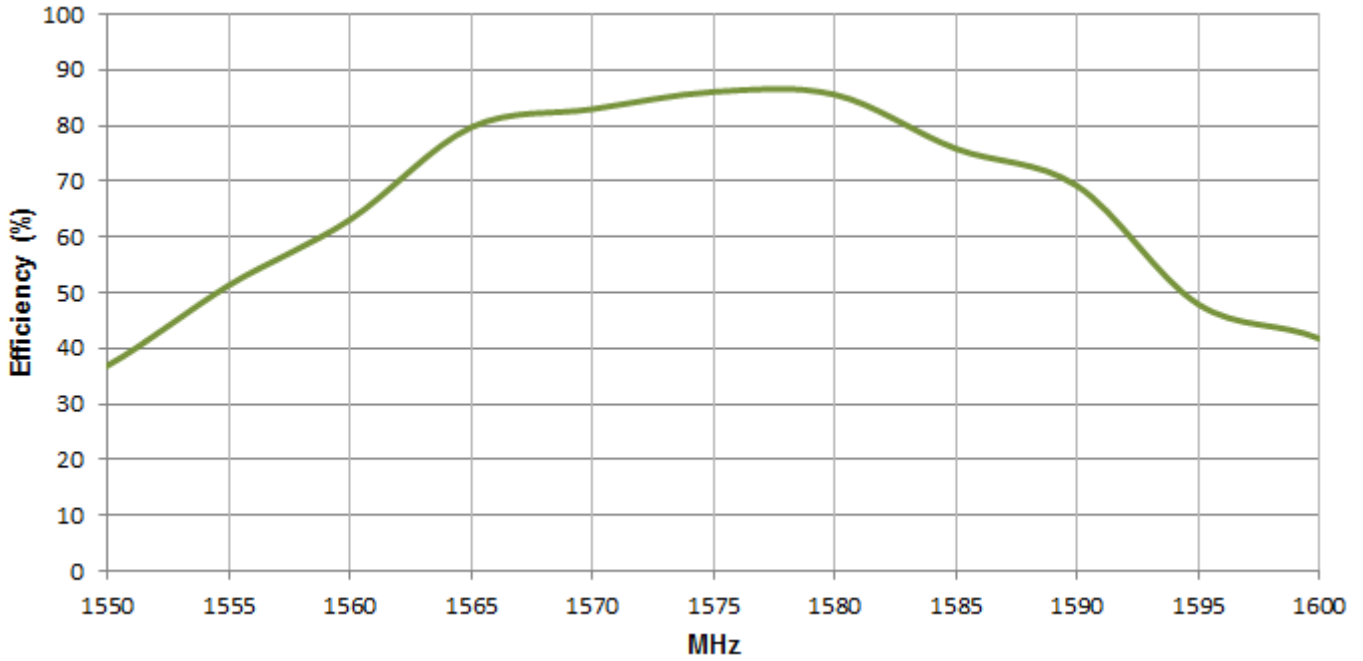

**Figure 5.** Efficiency of the GP.1575.35.A.02

### 4.4. Peak Gain

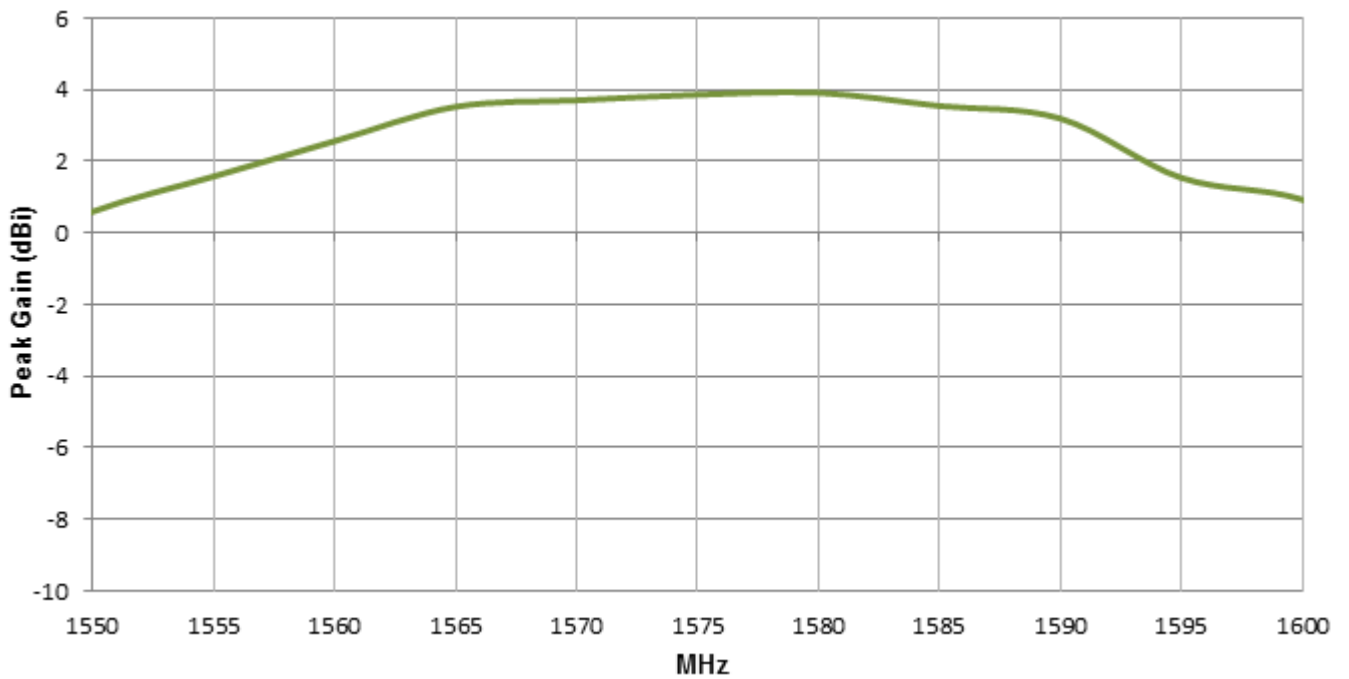

**Figure 6.** Peak Gain of the GP.1575.35.A.02.

## 5. 2D Radiation

### 5.1 XZ Plane Radiation

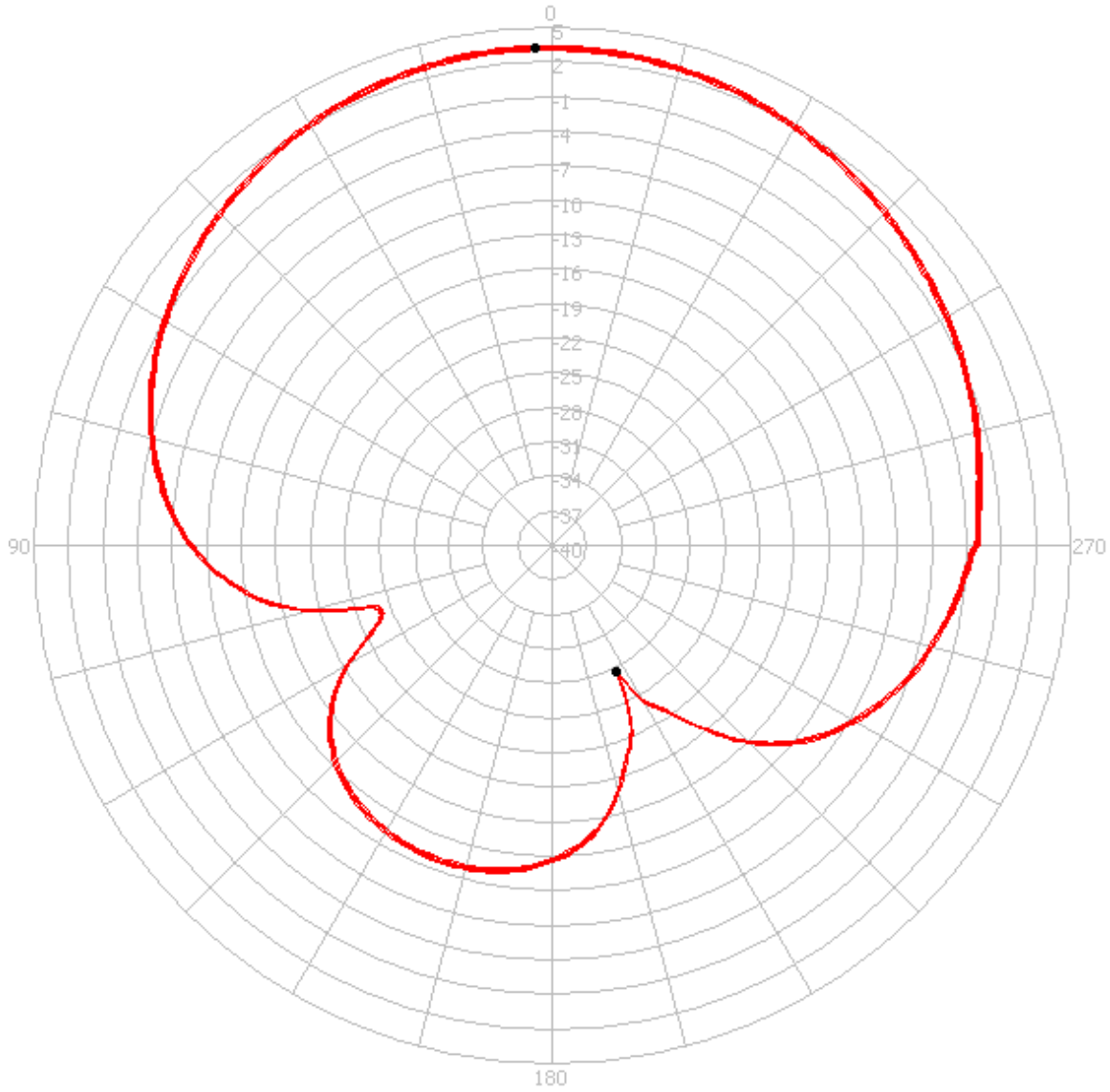

## 5.2 YZ Plane Radiation

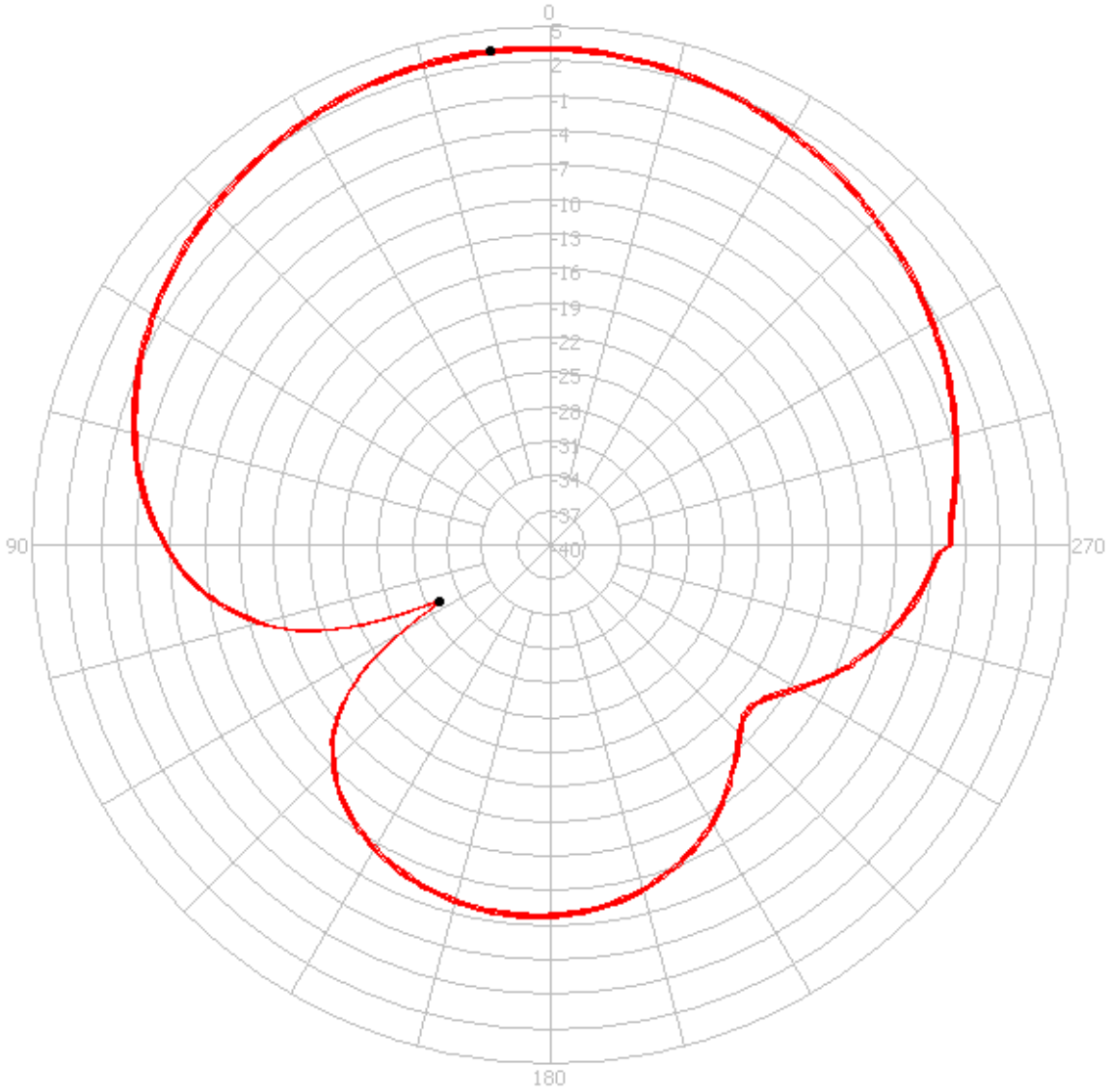

### 5.3 Axial Ratio

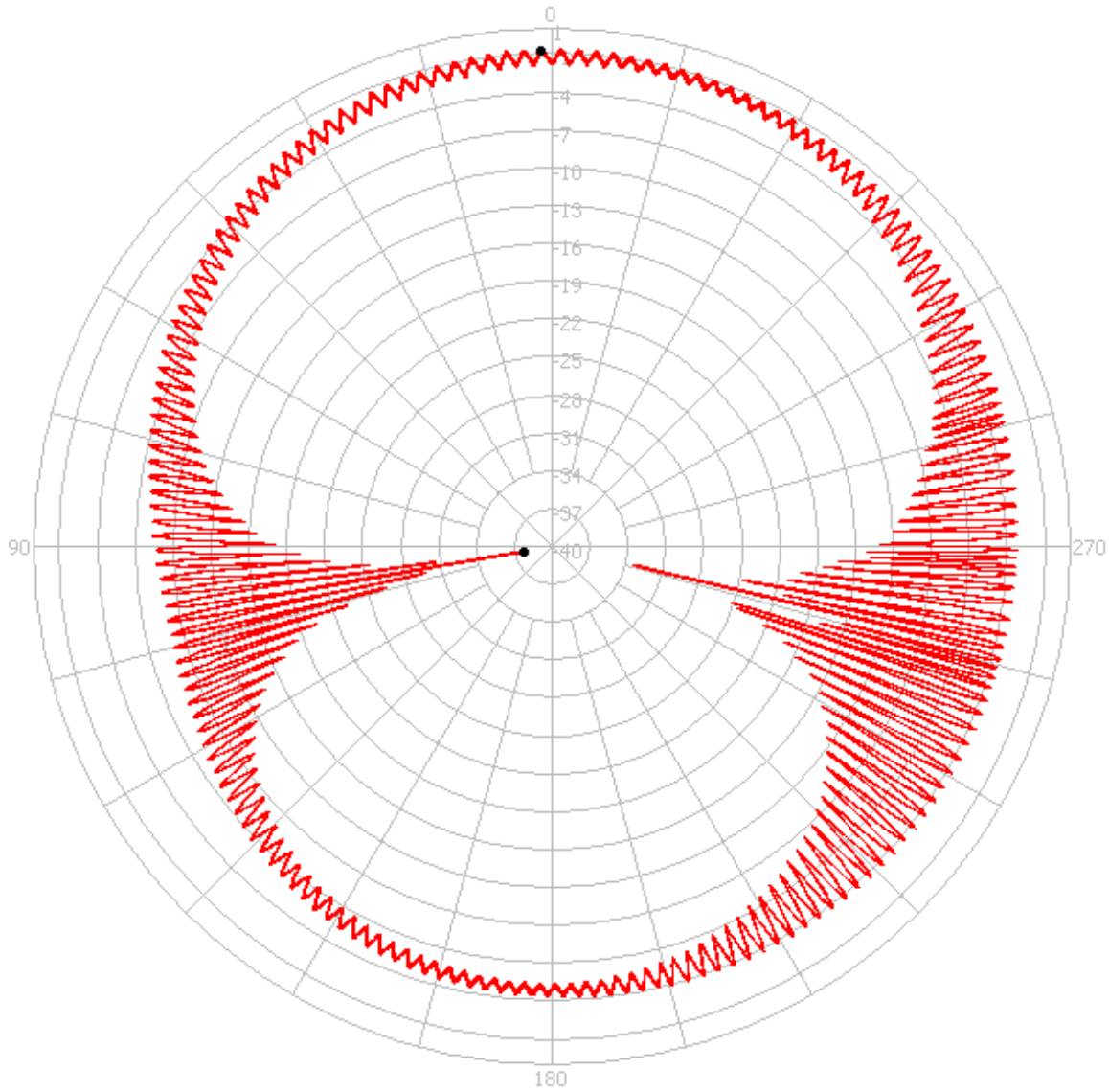

### 5.4 3D Radiation



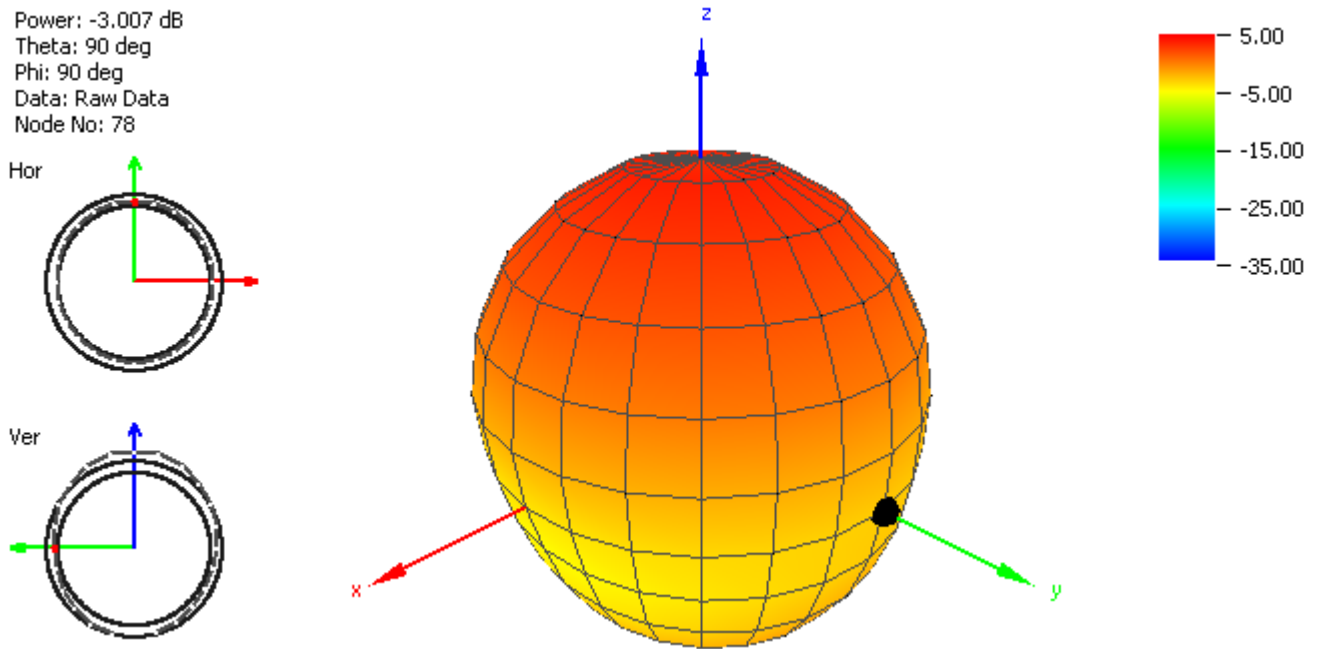

**Figure 7.** Radiation Pattern of the GP.1575.35.A.02 at 1575Mhz.

## 6 . Mechanical Drawing

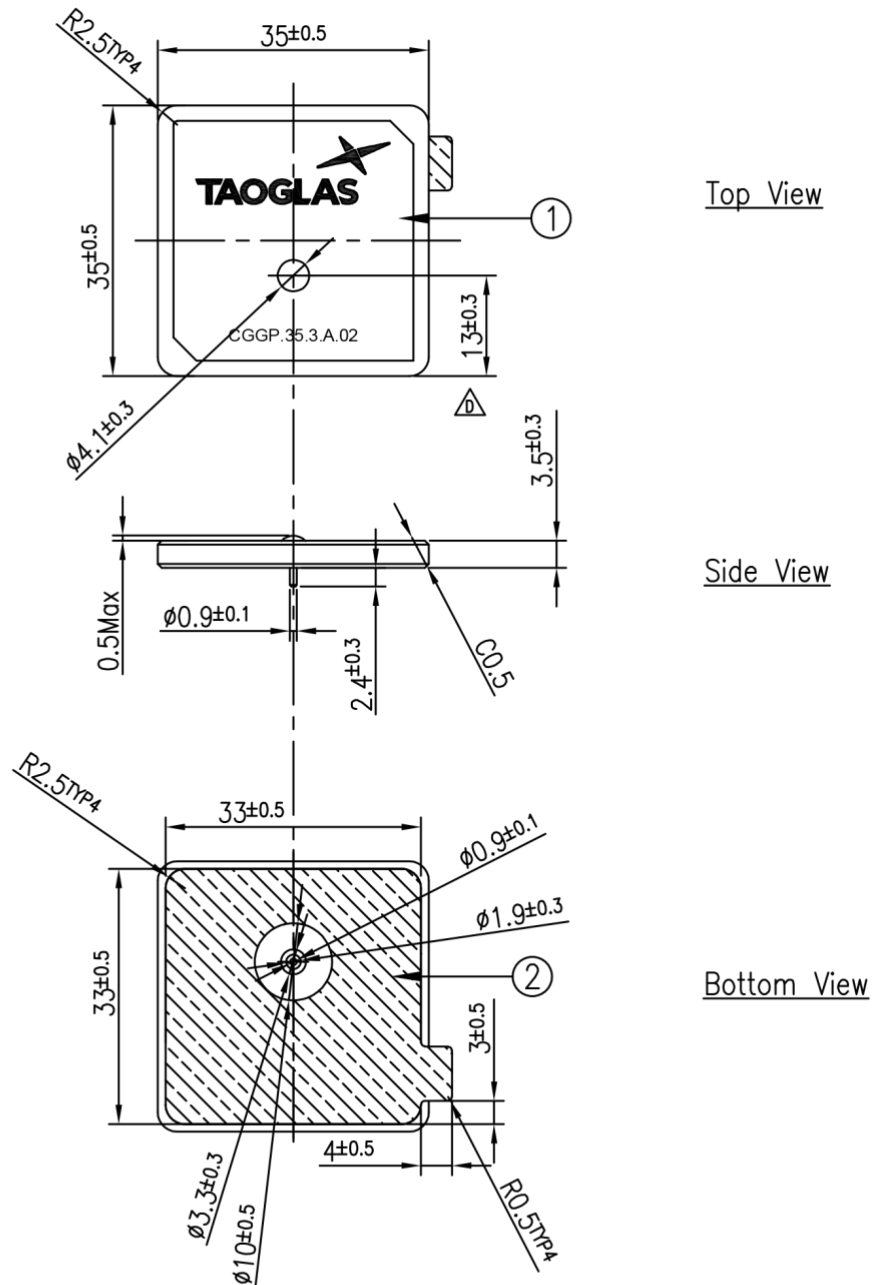

NOTES: 1. Double sided adhesive area 

	Name	P/N	Material	Finish	QTY
1	CGGP.35 Patch 35x35x3.5	001513C080007A	Ceramic	Clear	1
2	Double sided Adhesive	001013C020007A	NITTO 5015	White Linter	1

## 6.1 Adhesive Thickness

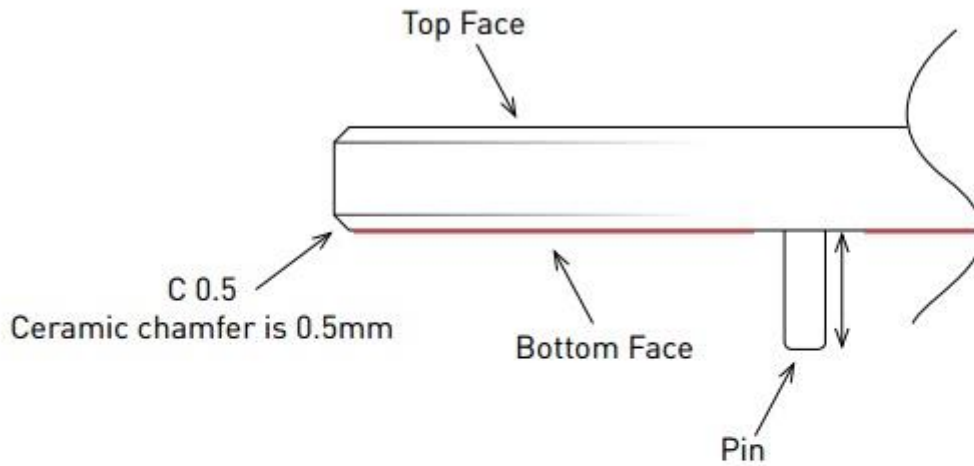

**Red Line** shows the adhesive without Liner – thickness 0.08–0.1mm

## 6.2 Layout Dimensions

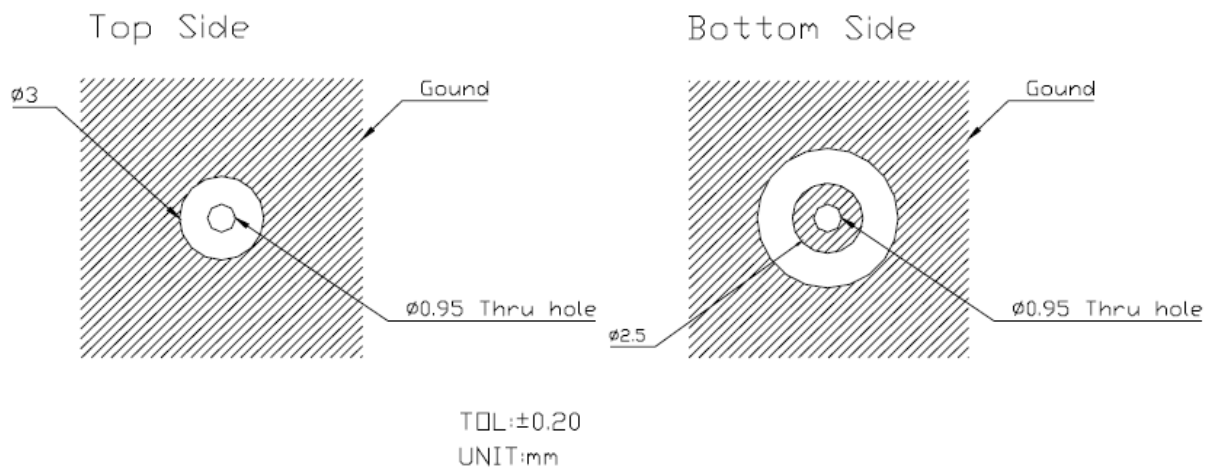

### 6.3 Test Fixture Antenna Setup and Measurements

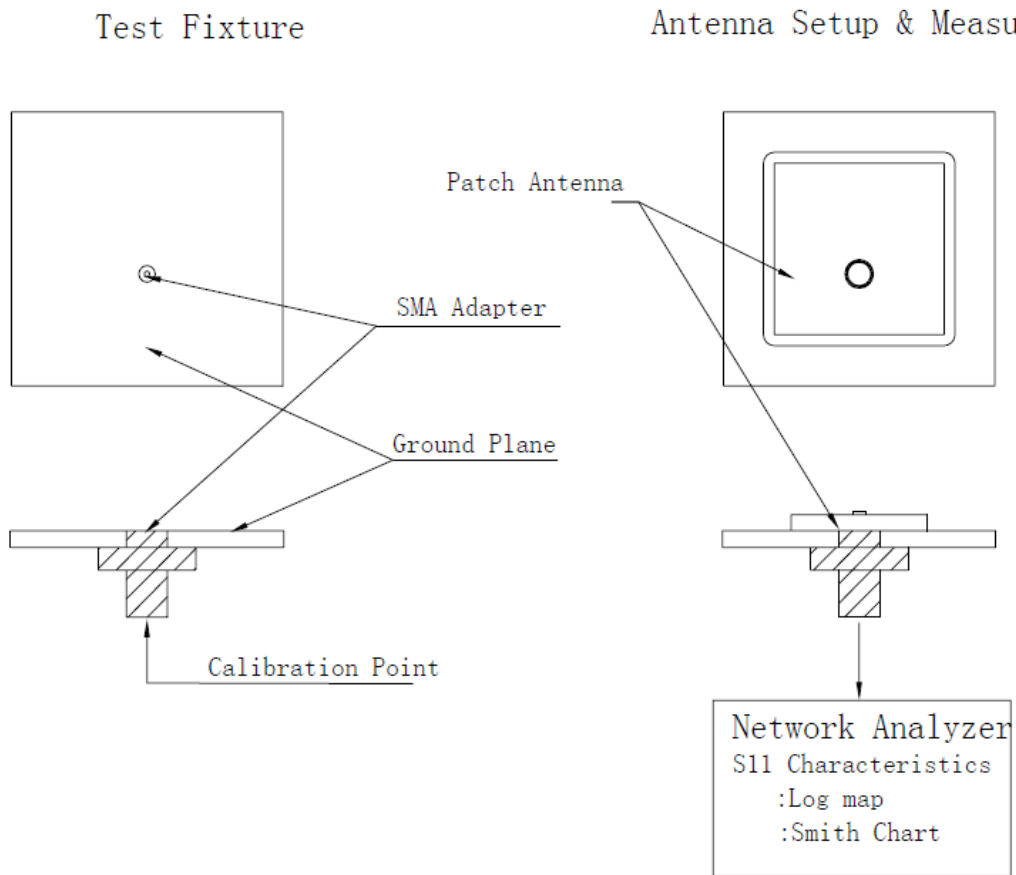

## 7. Packaging

### GP.1575.35.3.A.02

#### Packaging Specifications

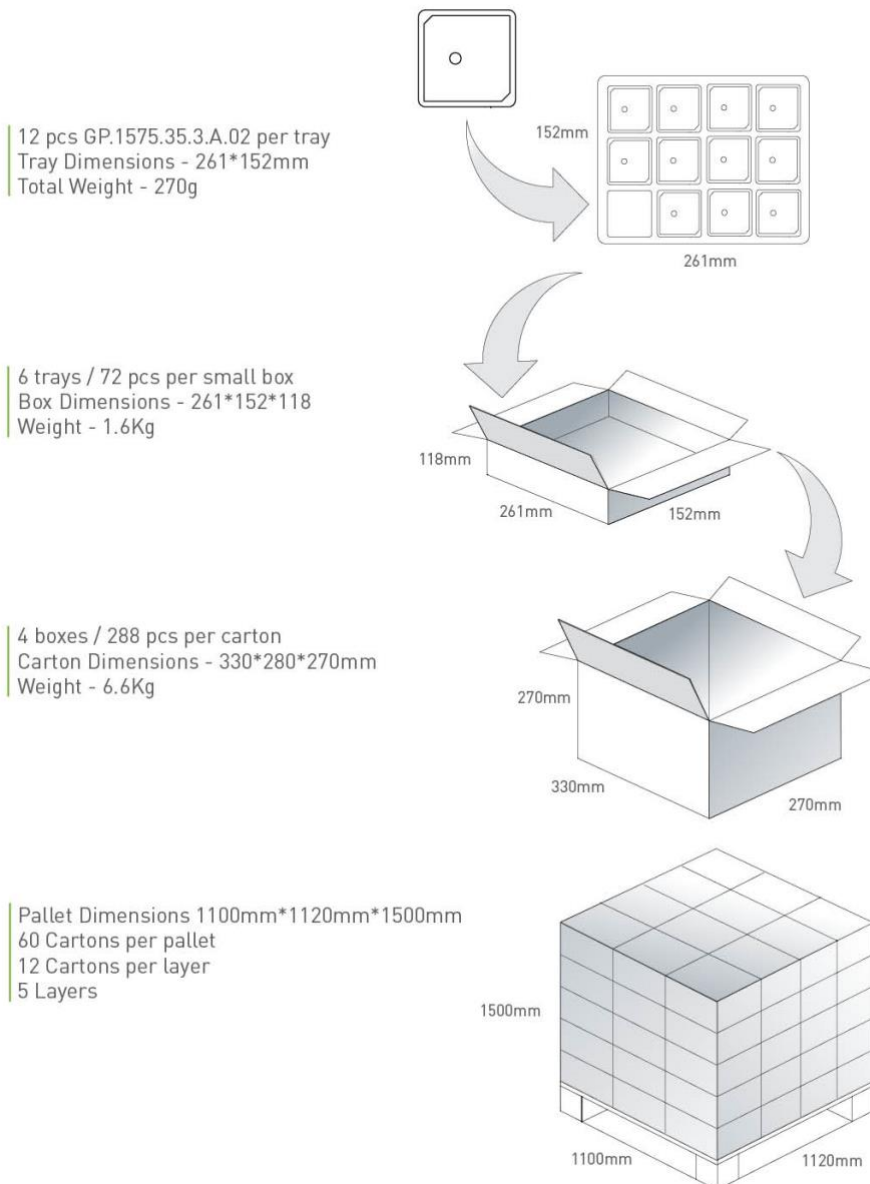

Taoglas makes no warranties based on the accuracy or completeness of the contents of this document and reserves the right to make changes to specifications and product descriptions at any time without notice. Taoglas reserves all rights to this document and the information contained herein.

Reproduction, use or disclosure to third parties without express permission is strictly prohibited.

Copyright © Taoglas Ltd.