



TAOGLAS®



Datasheet

Part No:
GGBLA.125.A

Description

GGBLA.125.A – GPS L1/L2/L5/L6, GLONASS, BeiDou Ceramic Loop Antenna for cm-Level with RTK

Features:

- Low Profile, Small Footprint Embedded Loop Antenna
- Centimeter-level accuracy achievable with RTK Systems
- GPS/QZSS (L1/L2)
- GPS/QZSS/IRNSS (L5)
- Galileo (E1/E5a/E5b/E6)
- GLONASS (G1/G2/G3)
- BeiDou (B1/B2a/B2b)
- Tuned for SMD Mounting on 80x40mm Ground Plane
- High efficiency, up to 80%
- Dimensions: 10 * 3.2 * 1.5 mm
- RoHS & Reach Compliant

1.	Introduction	2
2.	Specification	4
3.	Antenna Characteristics	6
4.	Radiation Patterns	9
5.	Field Test Results	17
6.	Mechanical Drawing	19
7.	Antenna Integration Guide	20
8.	Packaging	26
<hr/>		
	Changelog	27

Taoglas makes no warranties based on the accuracy or completeness of the contents of this document and reserves the right to make changes to specifications and product descriptions at any time without notice. Taoglas reserves all rights to this document and the information contained herein. Reproduction, use or disclosure to third parties without express permission is strictly prohibited.



1. Introduction



The Taoglas GGBLA.125.A is a unique embedded ceramic miniature loop antenna designed for GPS L1,L2, L5 and L6 applications. It also covers all GNSS requirements including GLONASS (L1PT, L1CR, L5R), Galileo (E1, E2, E5a, E5b, E6), BeiDou (B1, B2, B3), IRNSS(L5) & QZSS Frequencies.

With dimensions of just 10 x 3.2 x 1.5mm, a keep out area of just 15 x 9.8mm on the PCB, the GGBLA.125 makes an ideal multi band GNSS antenna solution for compact high precision automotive navigation or asset tracking devices where board space is at a premium. An SMD component, delivered on tape and reel, the middle edge-of-board mounted antenna, has an omnidirectional radiation pattern that allows customers to use an omnidirectional antenna in devices where orientation of the product may be unknown, or subject to frequent movement.

The wide bandwidth maintains high efficiency and reception stability on all GNSS bands from 1164MHz to 1602MHz. The GGBLA.125 exhibits efficiencies of between 60% and 80%, depending on the band used. With a peak gain of 2.6-3.6dBi, the gain performance compares with the ranges of much larger patch antennas of up to 18 x 18mm. Based on the loop antenna electrical effect, this antenna works best when placed in the center of the edge of the board.

Typical Applications Include:

- Navigation & RTK Systems
- Transportation, Marine & Agriculture
- Autonomous Vehicles
- UAVs and Robotics
- IOT Devices
- Location based applications

As with all onboard SMD antennas, care must be taken to ensure the device ground-plane layout and antenna matching has been done correctly. At any of our global design and test facilities, Taoglas can offer professional Gerber review, transmission line design, general integration support and final matching services of the GGBLA.125.A on your device board.

This antenna can be mounted with no performance degradation in either orientation as long as the antenna is soldered correctly via Surface mounting. Please see the integration instructions section for further detail regarding the optimum way to integrate this antenna into your device.

For further optimization to customer-specific device environments and for support to integrate and test this antennas performance in your device, contact your regional Taoglas Customer Services Team.

2. Specification

GNSS Frequency Bands					
GPS	L1 1575.42 MHz	L2 1227.6 MHz	L5 1176.45 MHz		
	■	■	■		
GLONASS	G1 1602 MHz	G2 1248 MHz	G3 1207 MHz		
	■	■	■		
Galileo	E1 1575.24 MHz	E5a 1176.45 MHz	E5b 1201.5 MHz	E6 1278.75 MHz	
	■	■	■	■	
BeiDou	B1C 1575.42 MHz	B1I 1561 MHz	B2a 1176.45 MHz	B2b 1207.14 MHz	B3 1268.52 MHz
	■	■	■	■	■
QZSS (Regional)	L1 1575.42 MHz	L2C 1227.6 MHz	L5 1176.45 MHz	L6 1278.75e6	
	■	■	■	■	
IRNSS (Regional)	L5 1176.45 MHz				
	■				
SBAS	L1/E1/B1 1575.42 MHz	L5/B2a/E5a 1176.45 MHz	G1 1602 MHz	G2 1248 MHz	G3 1207 MHz
	■	■	■	■	■
L-BAND (Correction data)	1525-1559				
	■				

Lower Bands

Upper Bands

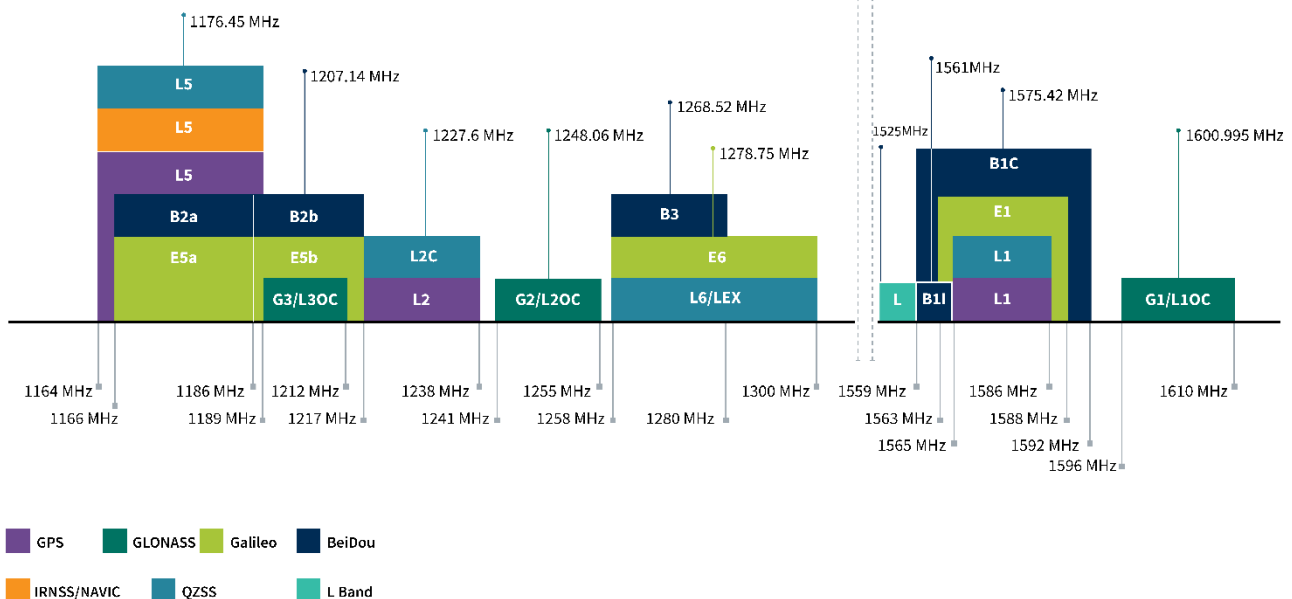

GNSS Electrical							
Frequency (MHz)	1176.45	1227.6	1278.75	1542	1561	1575.42	1602
VSWR (max.)	2:1	1:1	2:1	1:1	1:1	1:1	1:1
Passive Antenna Efficiency (%) (Without cable loss)	76.66	89.47	79.92	82.46	85.76	86.88	91.44
Passive Antenna Gain at Zenith (dBic) (Without cable loss)	3.52	3.41	2.22	2.92	3.03	3.03	2.94
Impedance	50 Ω						
Polarization	Linear						
Mechanical							
Dimensions (mm)	10 x 3.2 x 1.5 mm						
Weight (g)	0.17 g						
Environmental							
Operating Temperature	-40°C to 85°C						
Storage Temperature	-25°C to 85°C						
Relative Humidity	20°C to 70°C						
Moisture Sensitivity Level (MSL)	3 (168 Hours)						

3. Antenna Characteristics

3.1 Return Loss

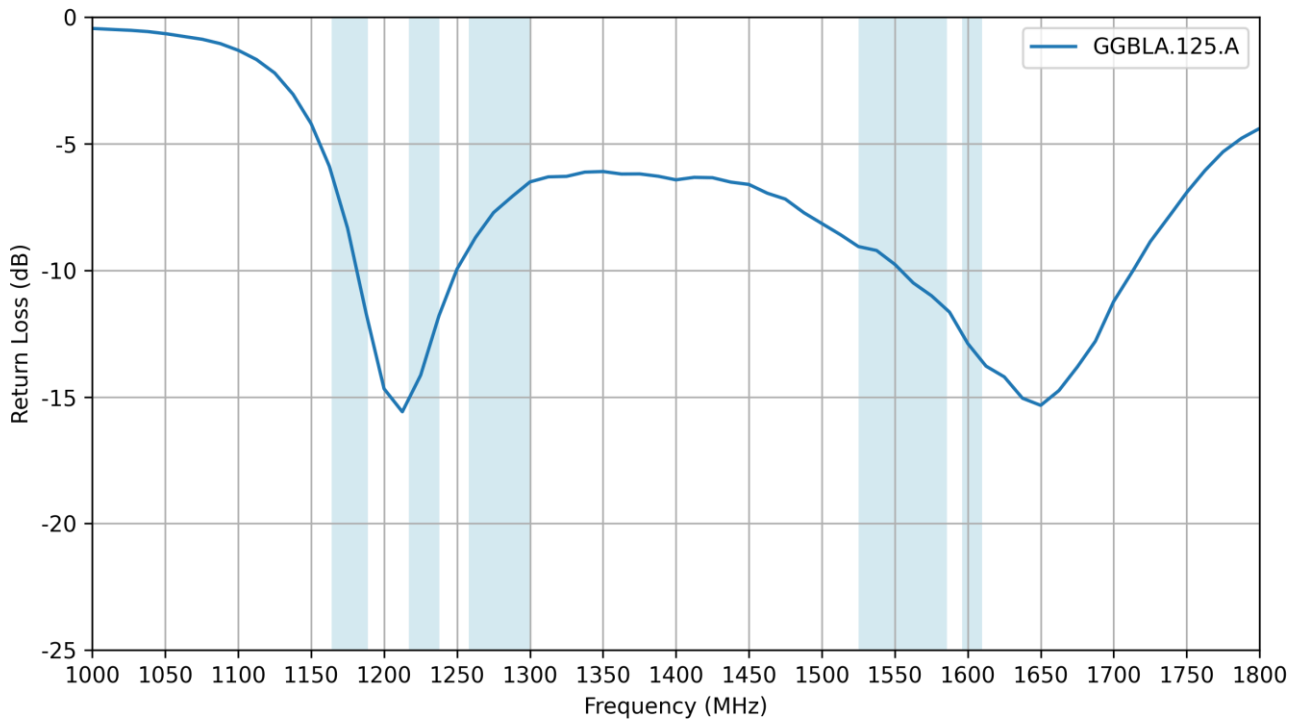

3.2 VSWR

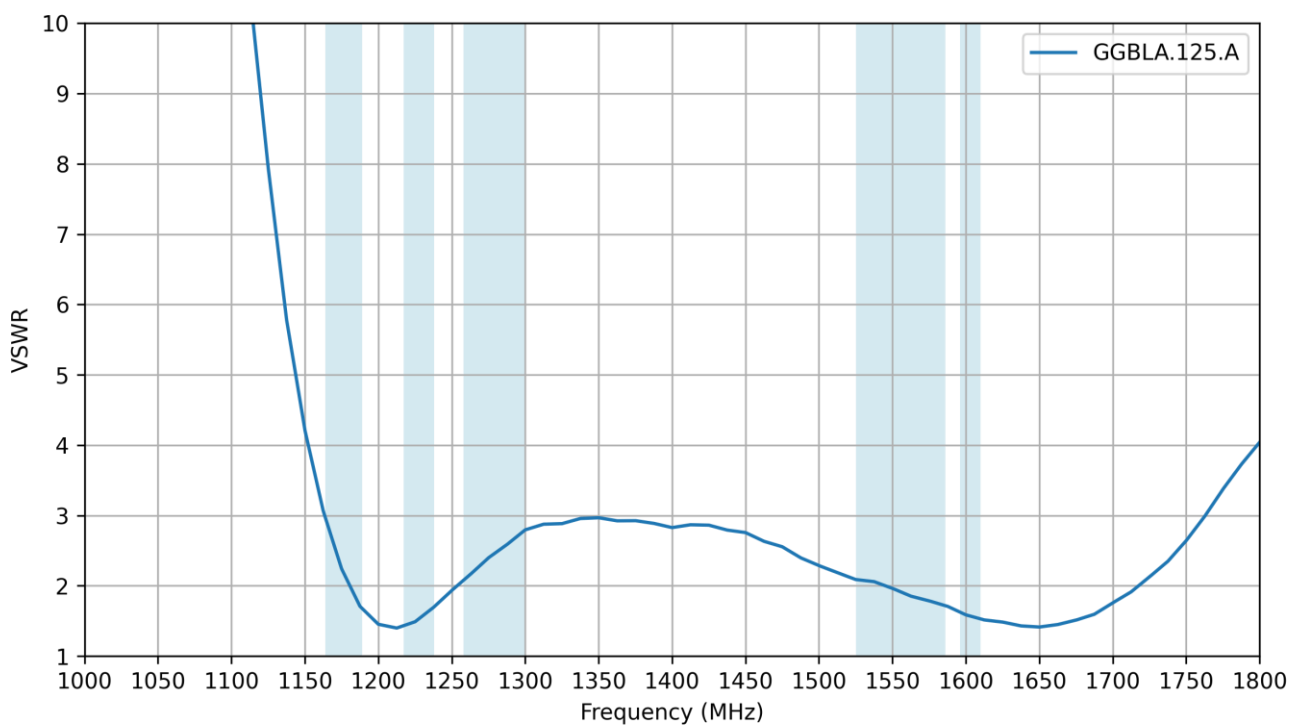

3.3 Efficiency

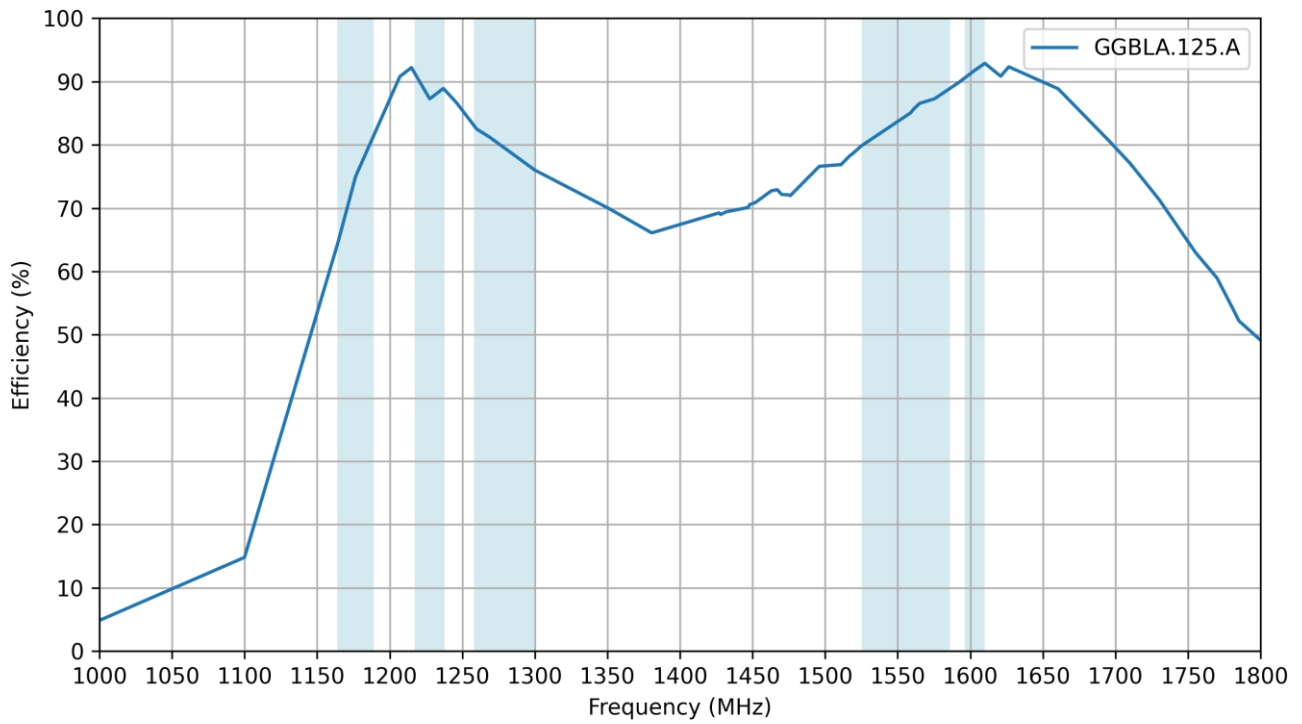

3.4 Average Gain

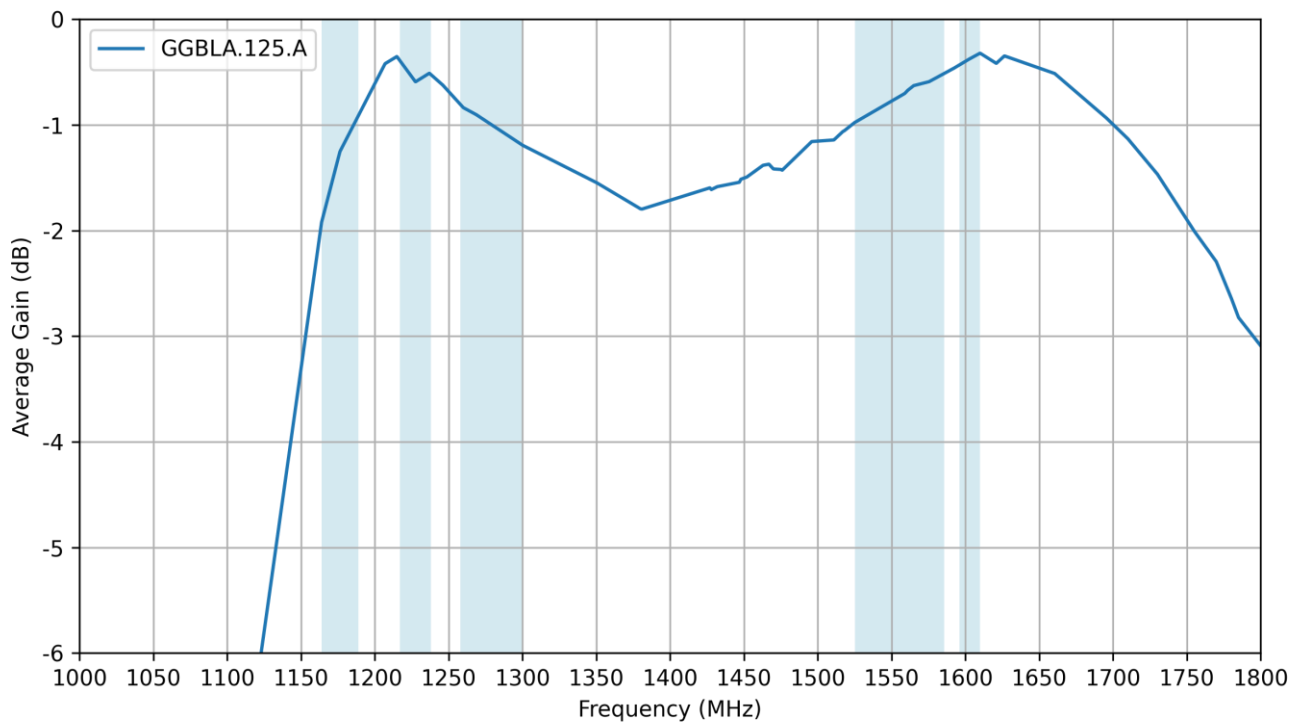

3.5 Peak Gain

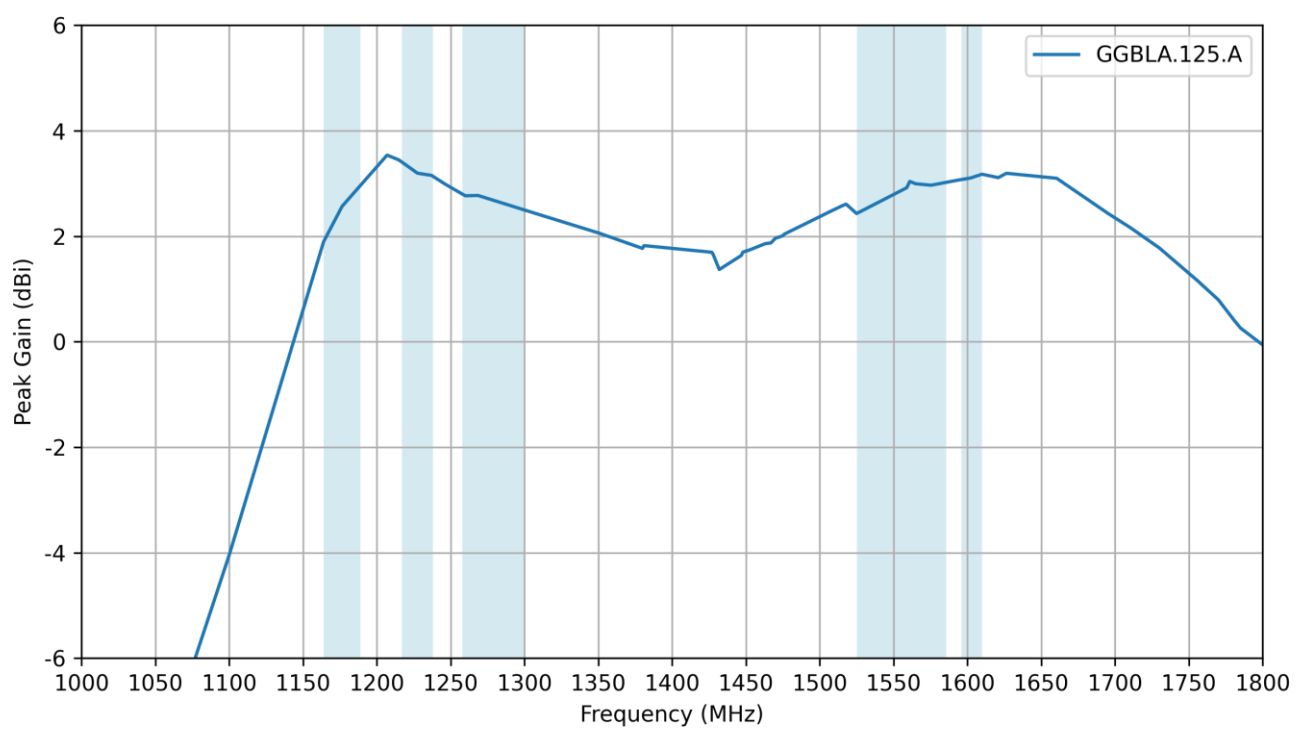

4. Radiation Patterns

4.1 Test Setup

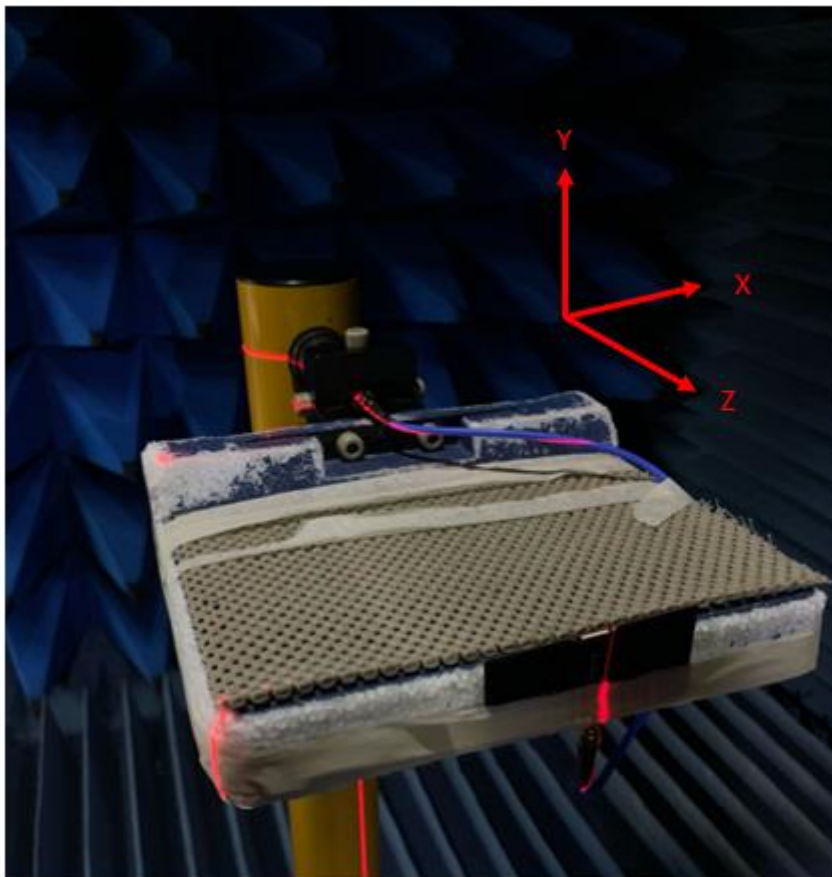
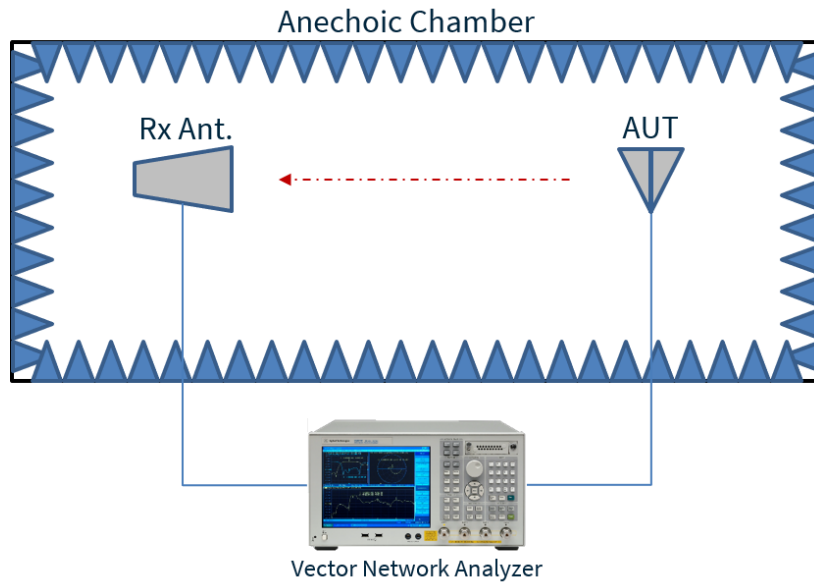

4.2 GGBLA.125.A Patterns at 1177 MHz

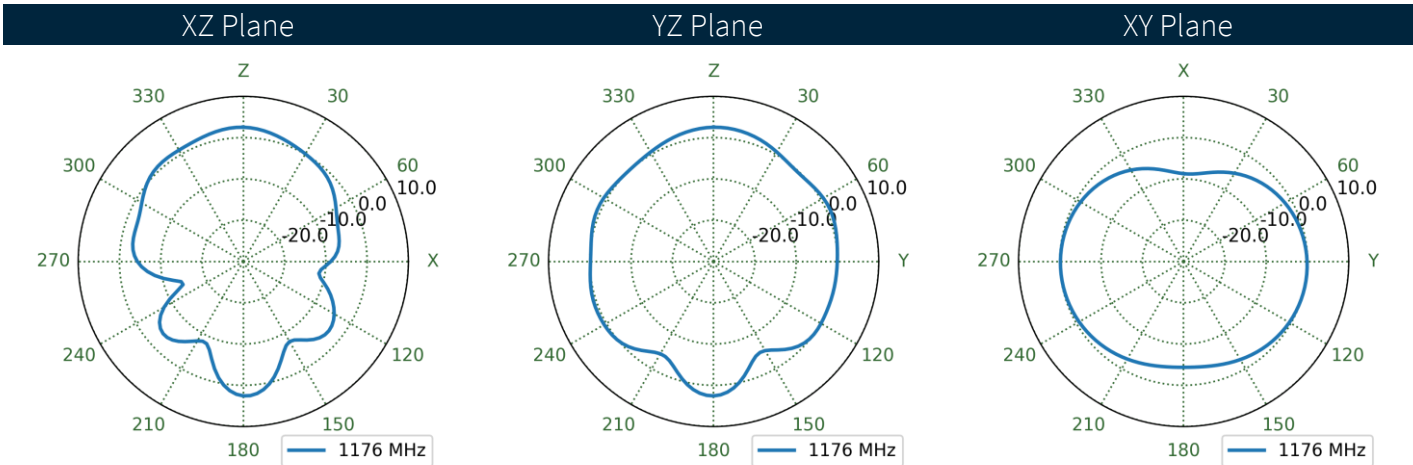
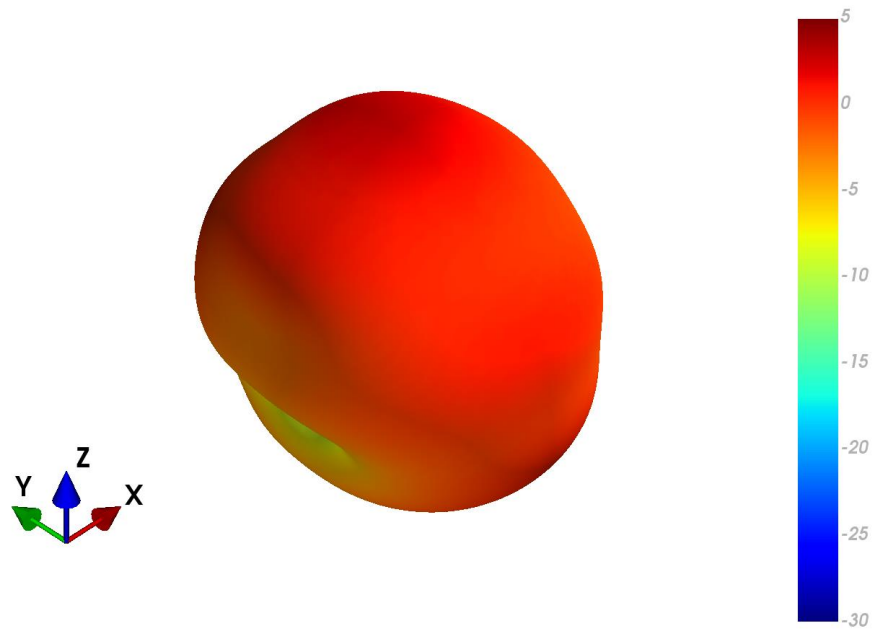

4.3 GGBLA.125.A Patterns at 1228 MHz

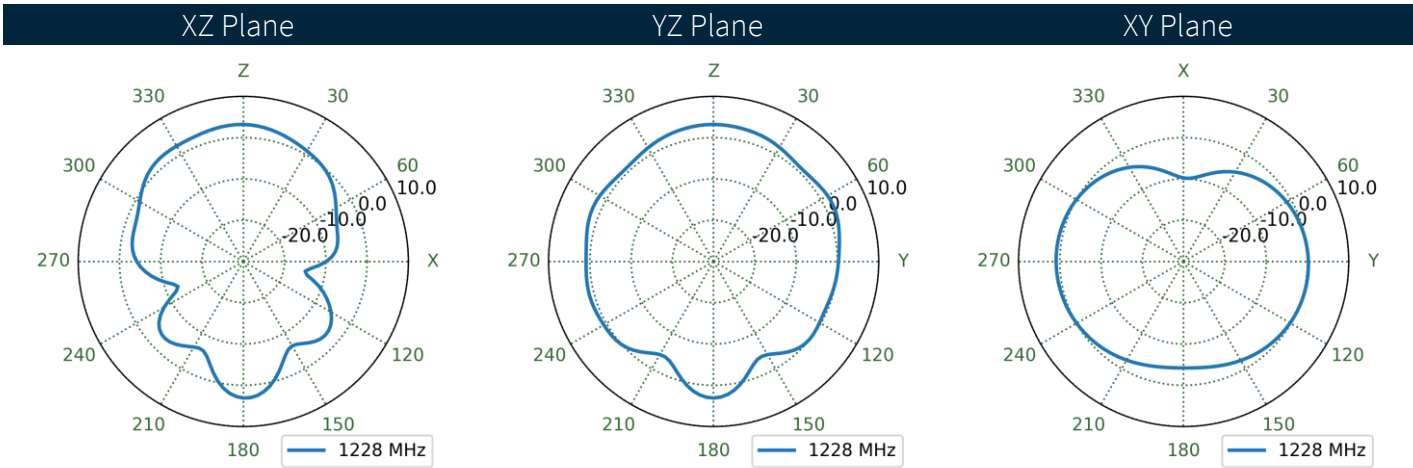
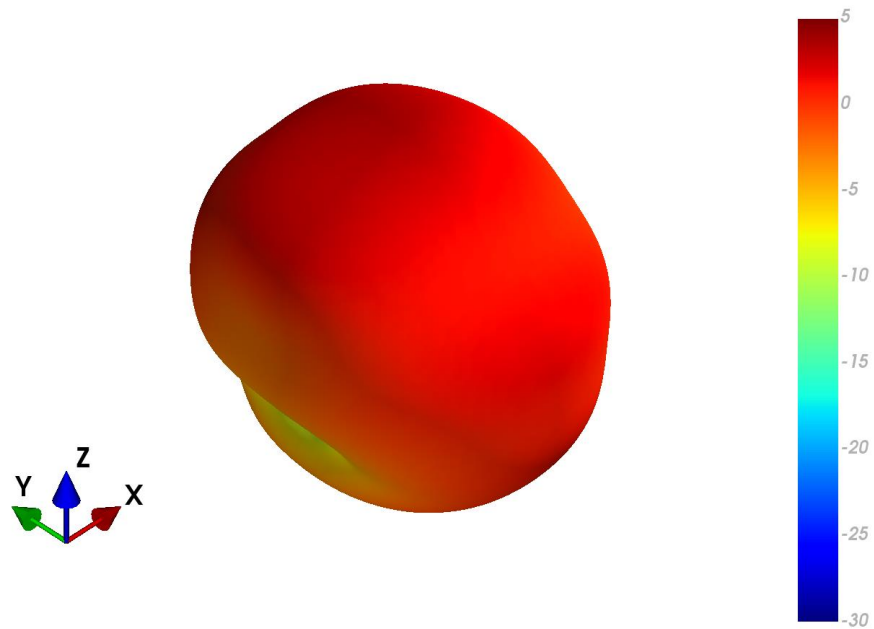

4.4 GGBLA.125.A Patterns at 1279 MHz

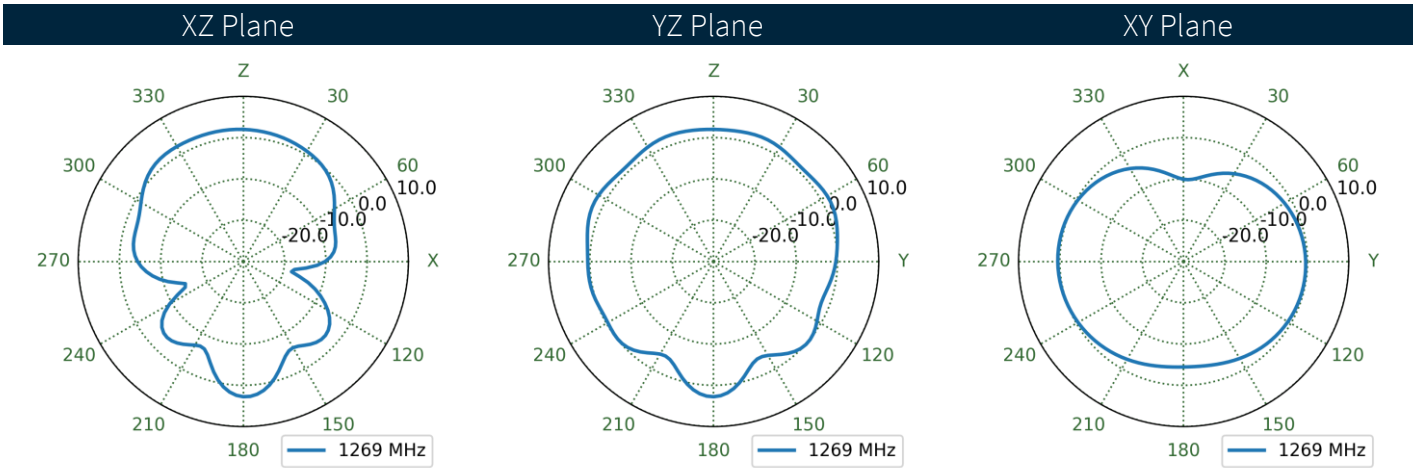
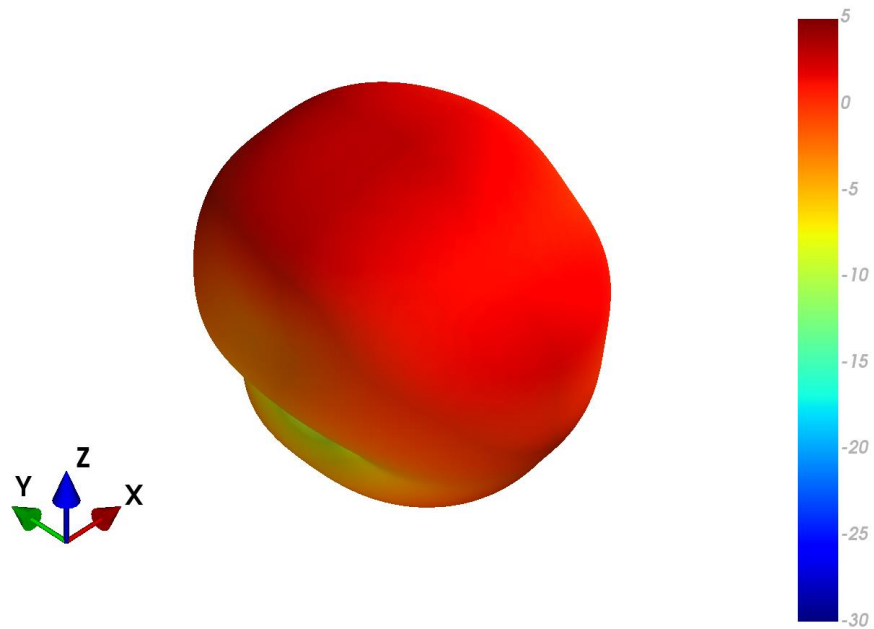

4.5 GGBLA.125.A Patterns at 1542 MHz

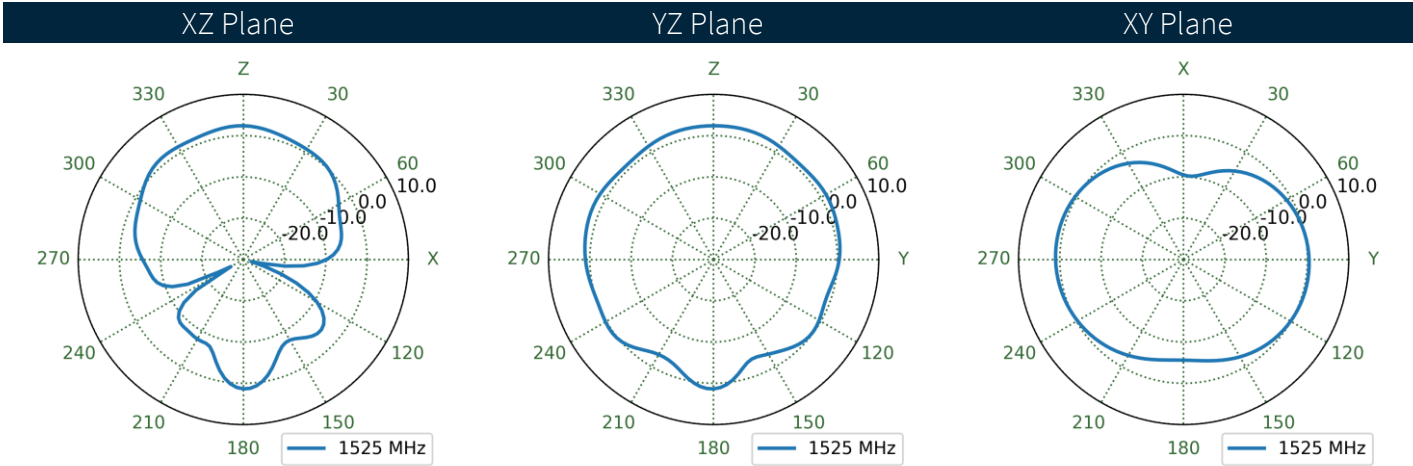
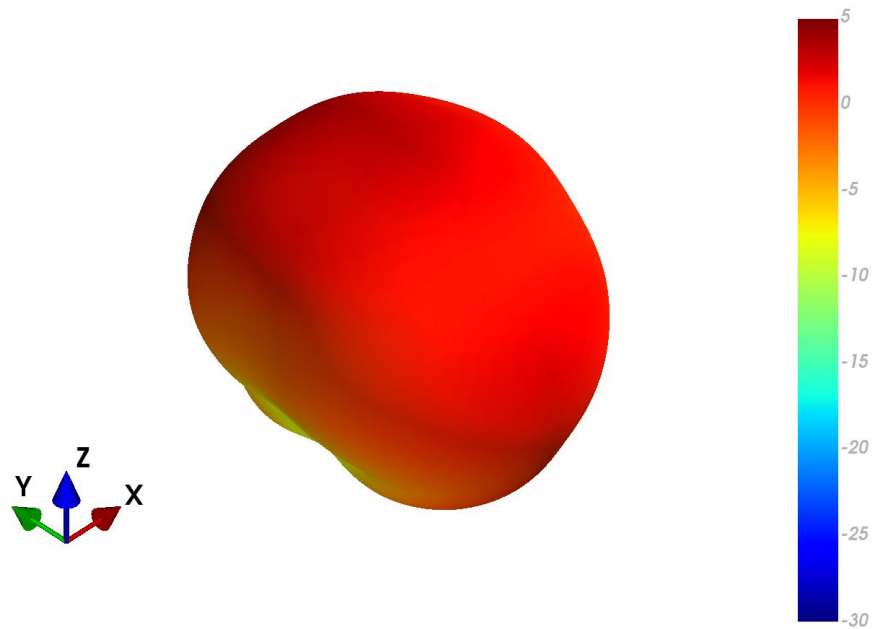

4.6 GGBLA.125.A Patterns at 1562 MHz

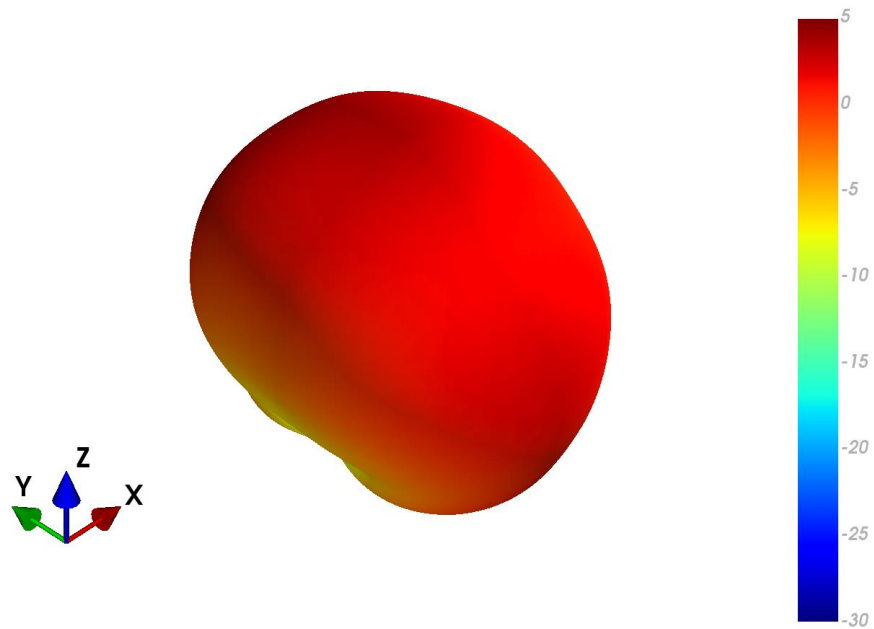

XZ Plane YZ Plane XY Plane

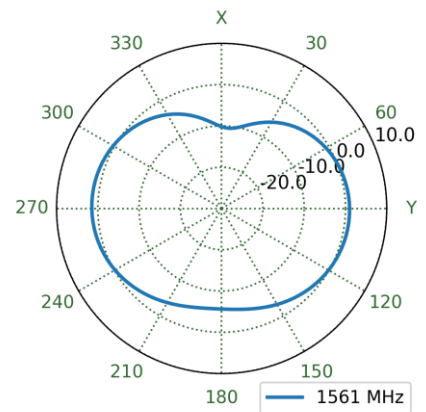
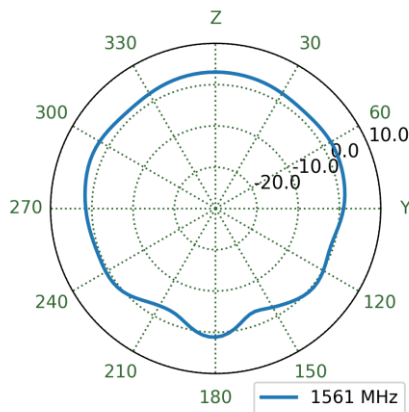
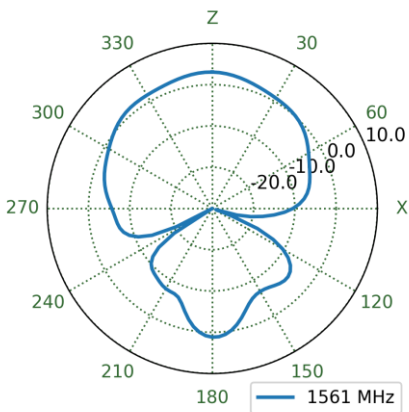

4.7 GGBLA.125.A Patterns at 1576 MHz

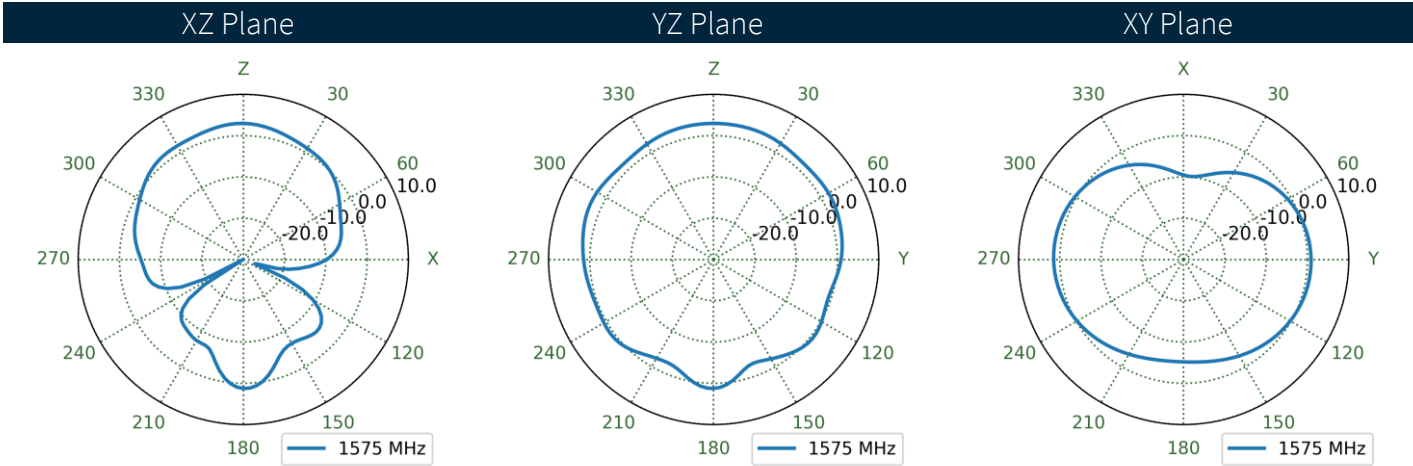
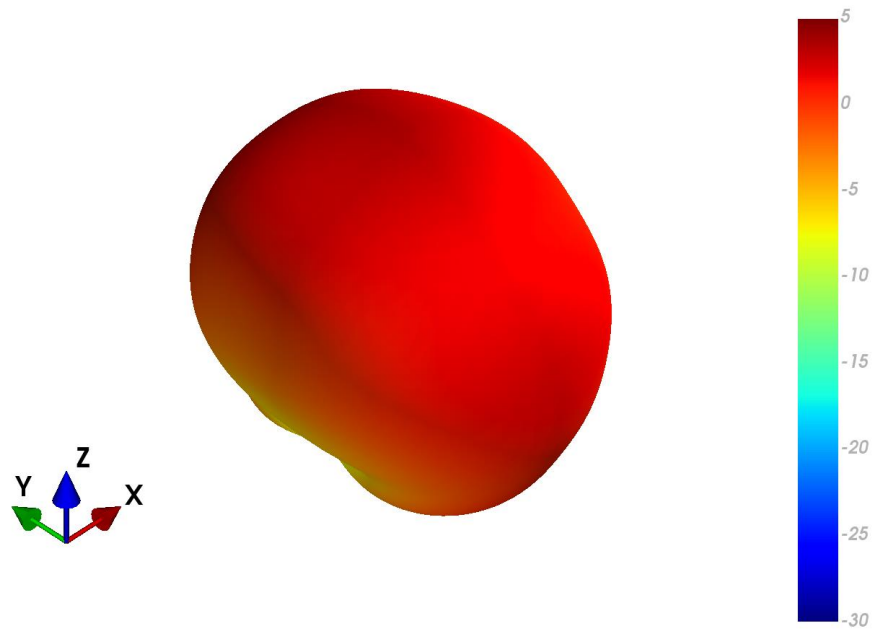

4.8 GGBLA.125.A Patterns at 1603 MHz

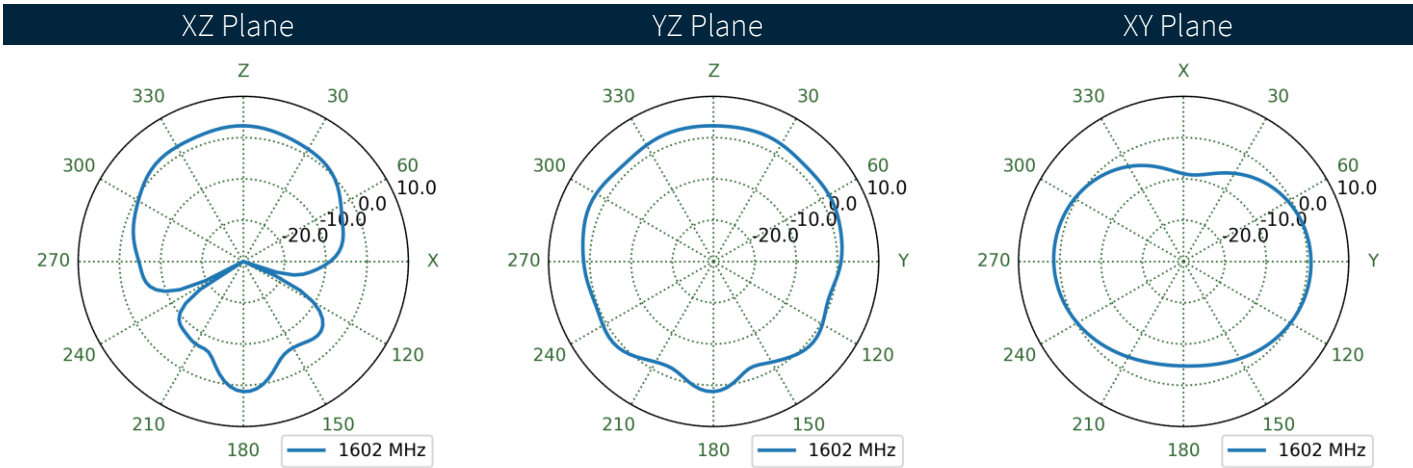
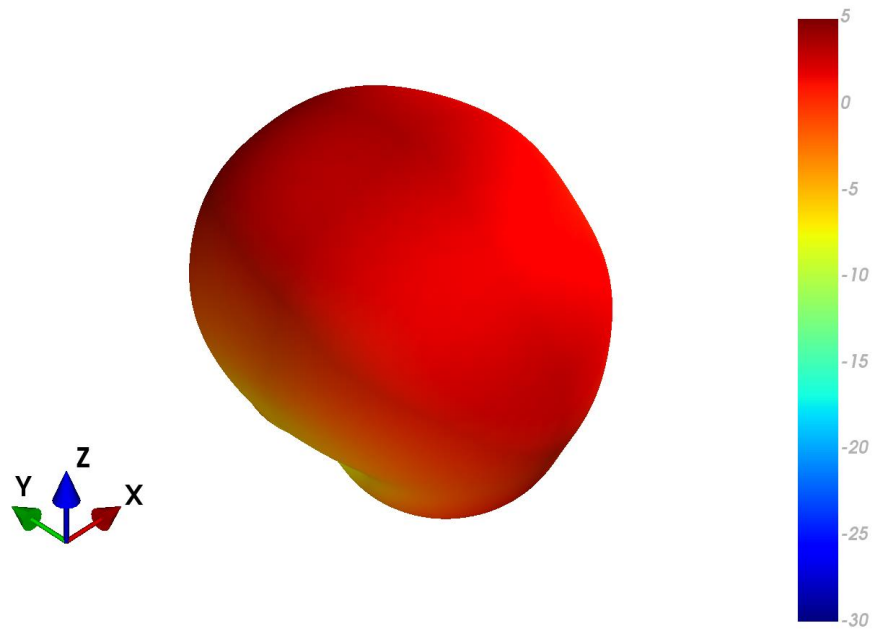

5. Field Test Results

This section outlines the field test result for GGBLA.125.A antenna. The test was performed when the antenna was mounted on a static rooftop test set up in an open sky environment for a minimum of 6 hours.

Taoglas will show the field test results using the following receivers:

5.1 UBlox ZED-F9P-0XB

Receiver features:

- Multi-band GNSS: 184-channel GPS L1C/A L2C, GLONASS: L1OF L2OF, Galileo: E1B/C E5b, BeiDou: B1I B2I, QZSS: L1C/A L2C
- Multi-band RTK with fast convergence times and reliable performance
- Nav. update rate RTK up to 20 Hz
- Position accuracy = RTK 0.01 m + 1 ppm CEP

Positioning Accuracy Table (2D Accuracy)					
Test Condition	Correction Service	CEP (50%)	DRMS (68%)	2DRMS (95-98.2%)	TTF (sec)
EVB	RTK DISABLED	106.72 cm	134.17 cm	268.34 cm	32
	RTL ENABLED	10.59 cm	12.88 cm	25.75 cm	32

RTK Availability

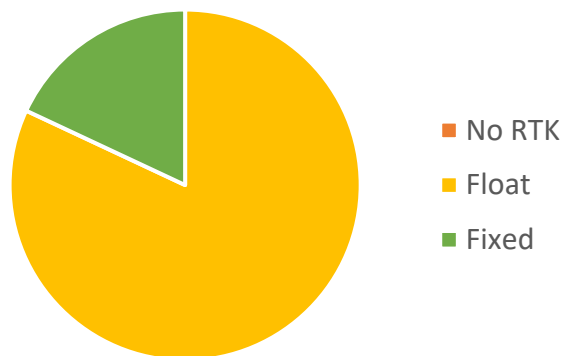

5.2 Ublox NEO-F9P-15B

Receiver features:

- Multi-band GNSS: GPS / QZSS (L1C/A, L5) GLONASS (L1OF) Galileo (E1-B/C, E5a) BeiDou (B1I, B2a) NavIC (SPS-L5)
- Multi-band PPP-RTK with fast convergence times and reliable performance
- Nav. update rate RTK up to 25 Hz
- Position accuracy = RTK 0.01 m + 1 ppm CEP

Positioning Accuracy Table (2D Accuracy)					
Test Condition	DRMS(cm)	CEP (50%)	DRMS (68%)	2DRMS (95-98.2%)	TTF (sec)
EVB	PPP-RTK DISABLED	72.58	87.31	174.61	19
	PPP-RTK ENABLED	11.94	14.38	28.76	23

*The RTK correction service used in previous measurements provides superior corrections compared to the PPP-RTK service used for measurements on the NEO-F9P.

PPP-RTK Availability EVB

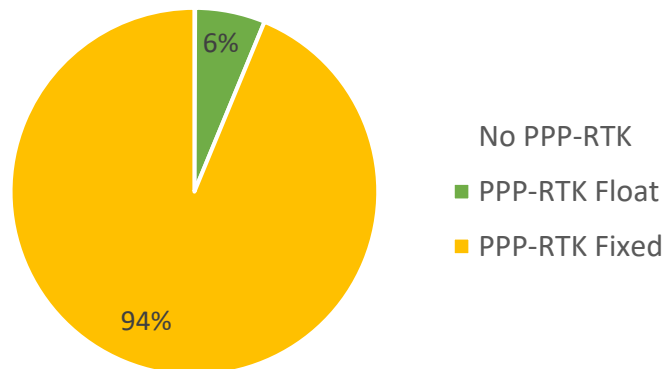

6. Mechanical Drawing

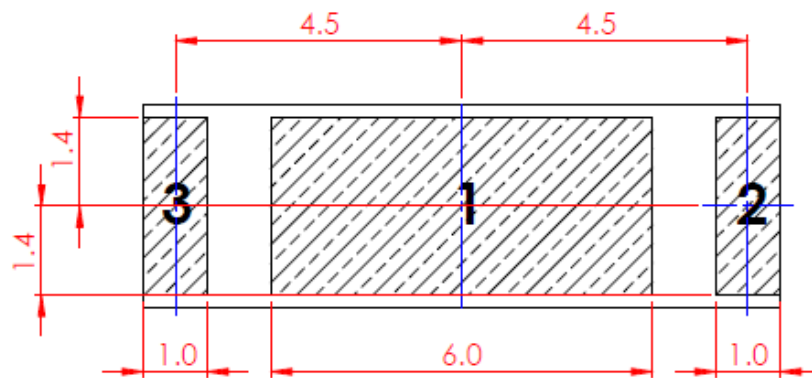
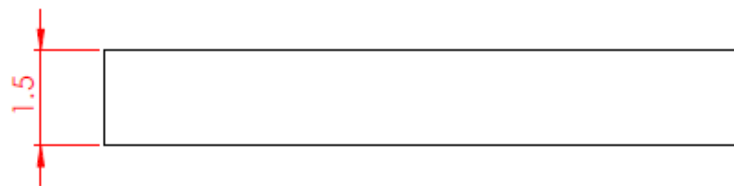
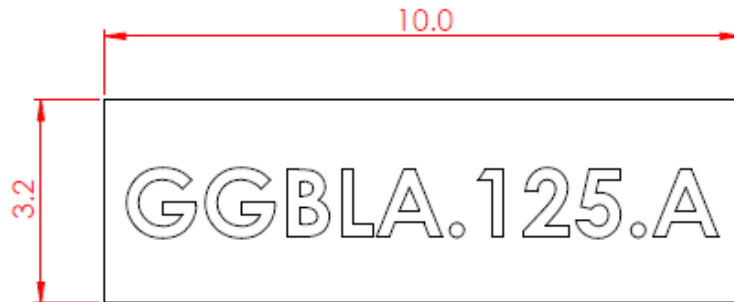

<u>PIN:</u>	<u>DESCRIPTION:</u>
1	Feed (50 ohm)
2,3	Ground

7. Antenna Integration Guide

GGBLA.125.A

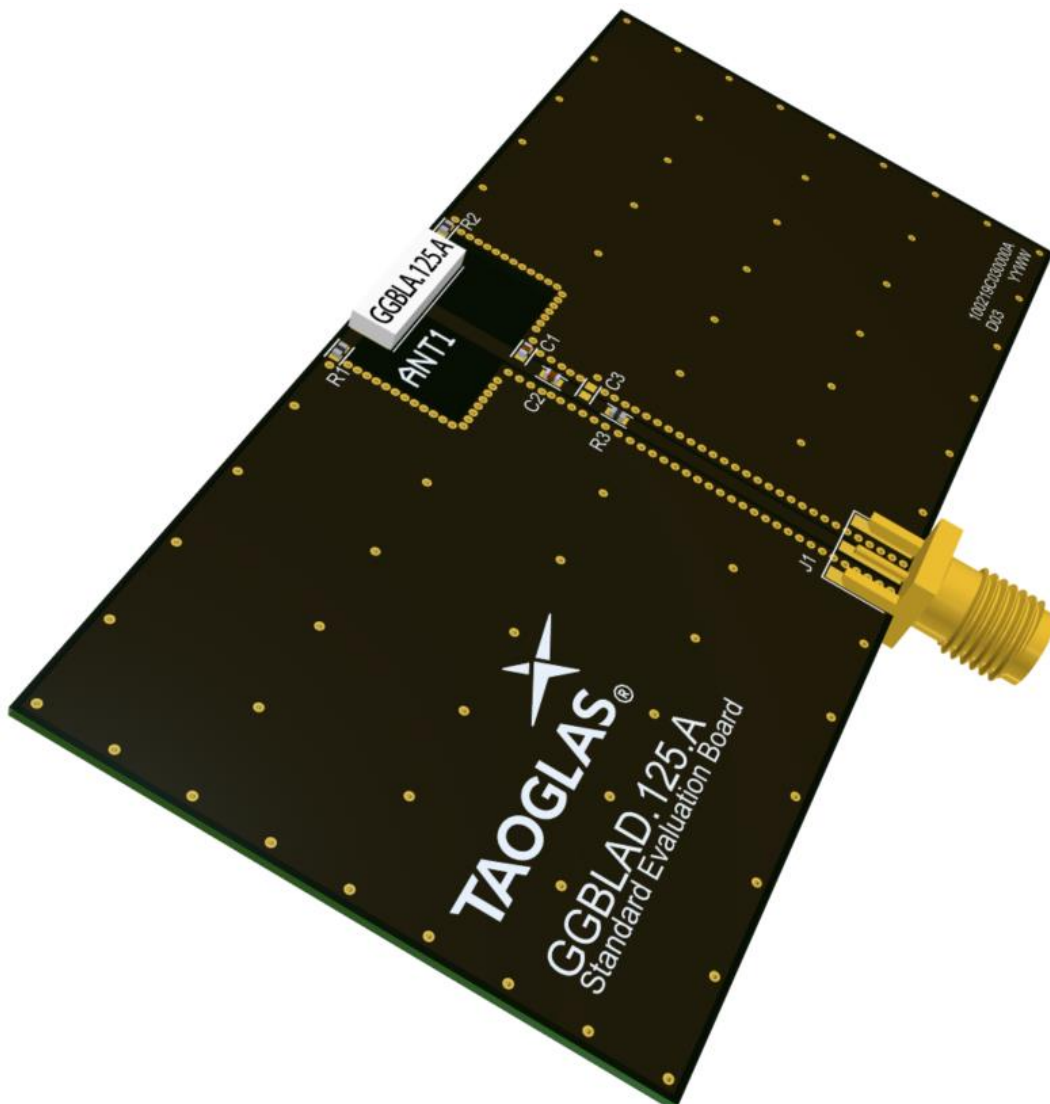

7.1 Schematic Symbol and Pin Definitions

The circuit symbol for the antenna is shown below. The antenna has 3 pins with all three pins as functional.

Pin	Description
1	RF Feed
2, 3	Ground

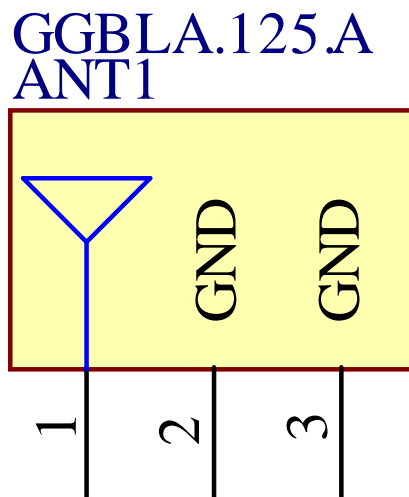

Please note you can download the design files & 3D model from the website here:

<https://www.taoglas.com/product/ggbla-125-a-gps-l1-l2-l5-glonass-beidou-ceramic-loop-antenna/>

7.2 Antenna Integration Guide

For any given PCB size, the antenna should ideally be placed on the centre edge of the PCB's longest side, to take advantage of the ground plane. Optimized matching components (R1,R2,R3,C1,C2,C3) can be placed as shown.

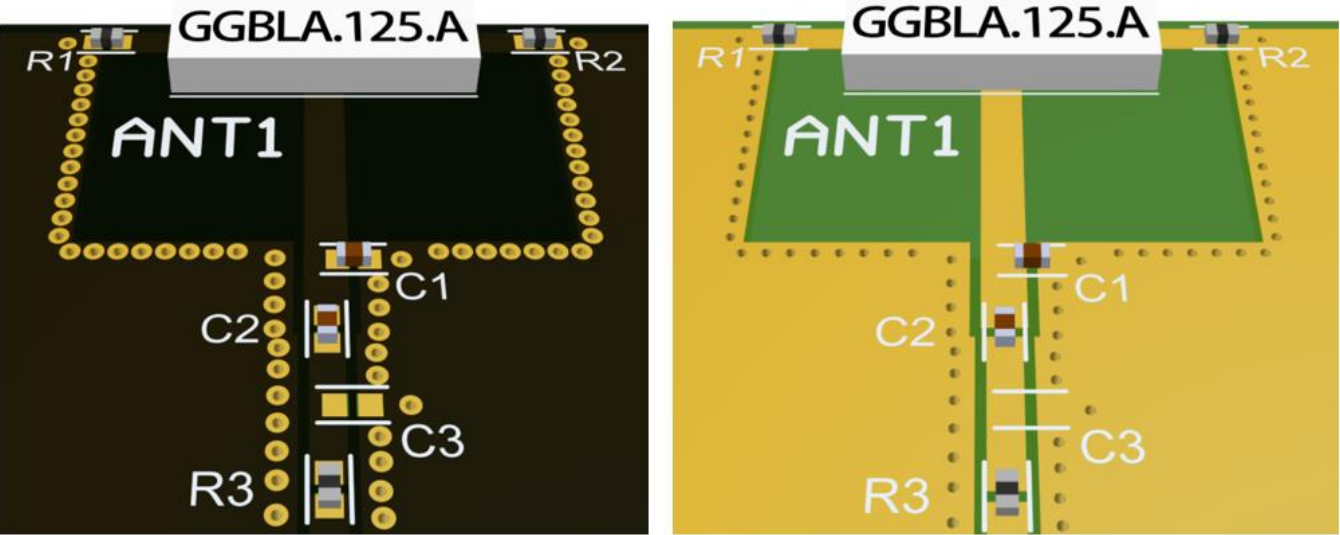

7.3 PCB Layout

The footprint and clearance on the PCB must meet the layout drawing in (7.7). Note the placement of the optimized components. C1 is placed as close as possible to the RF feed (pad 1) but still outside the keep out area. C2 is then placed tightly in series after that followed by C3 and then R3 in series. C3 is an optional component but the footprint is recommended in case it is needed. R1 & R2 are placed as close as possible to GND (pads 2 & 3).

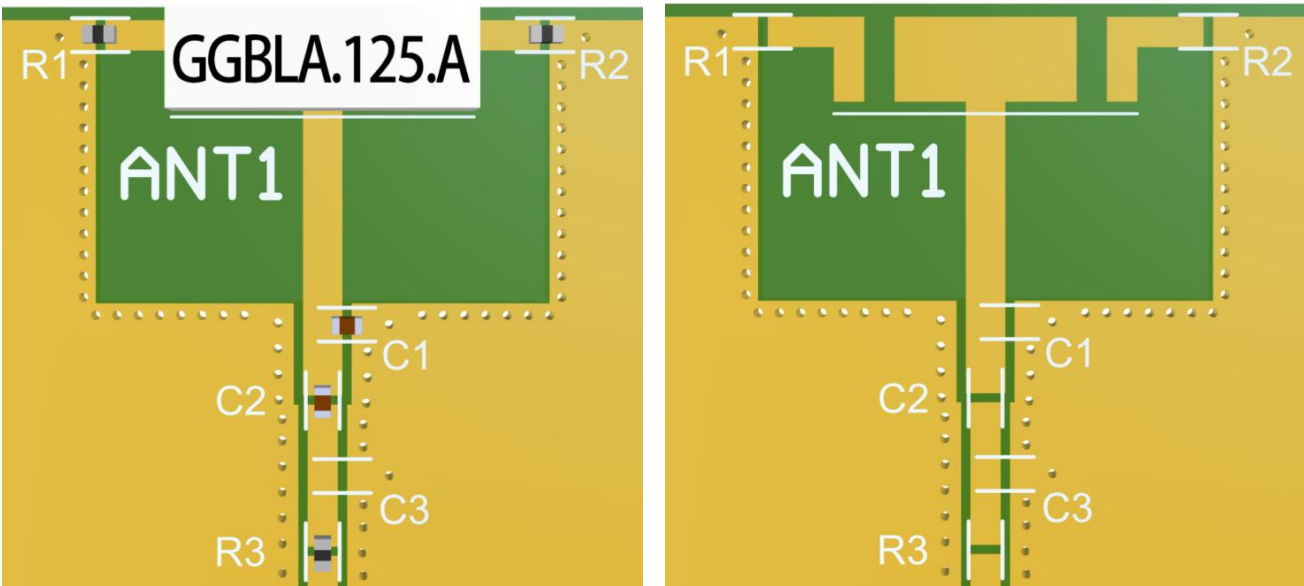

7.4 PCB Clearance

Below shows the antenna footprint and clearance through ALL layers on the PCB. Only the antenna pads and connections to feed and GND are present within this clearance area (marked RED). The clearance area extends to 9.8mm in length and 15mm in width. This clearance area includes the bottom side and ALL internal layers on the PCB.

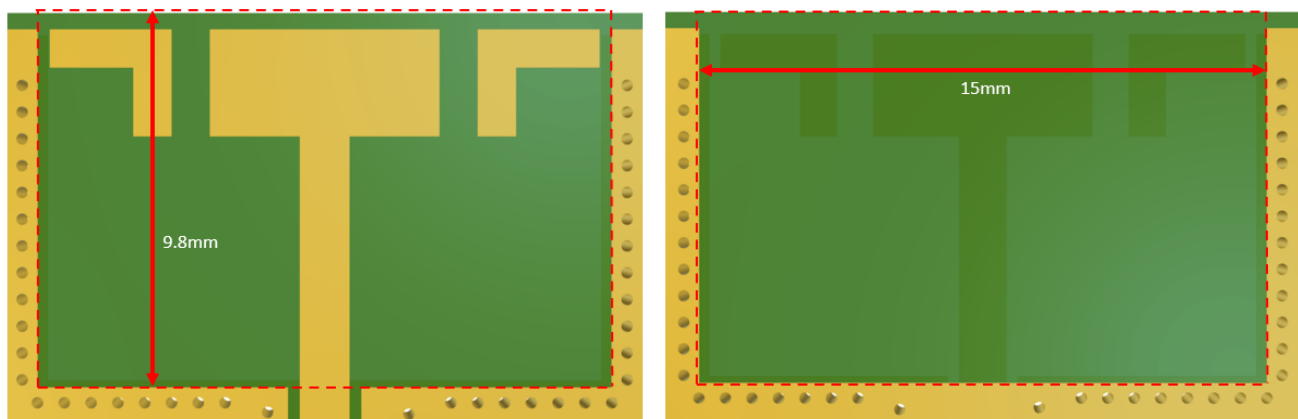

7.5 Evaluation Board Dimensions

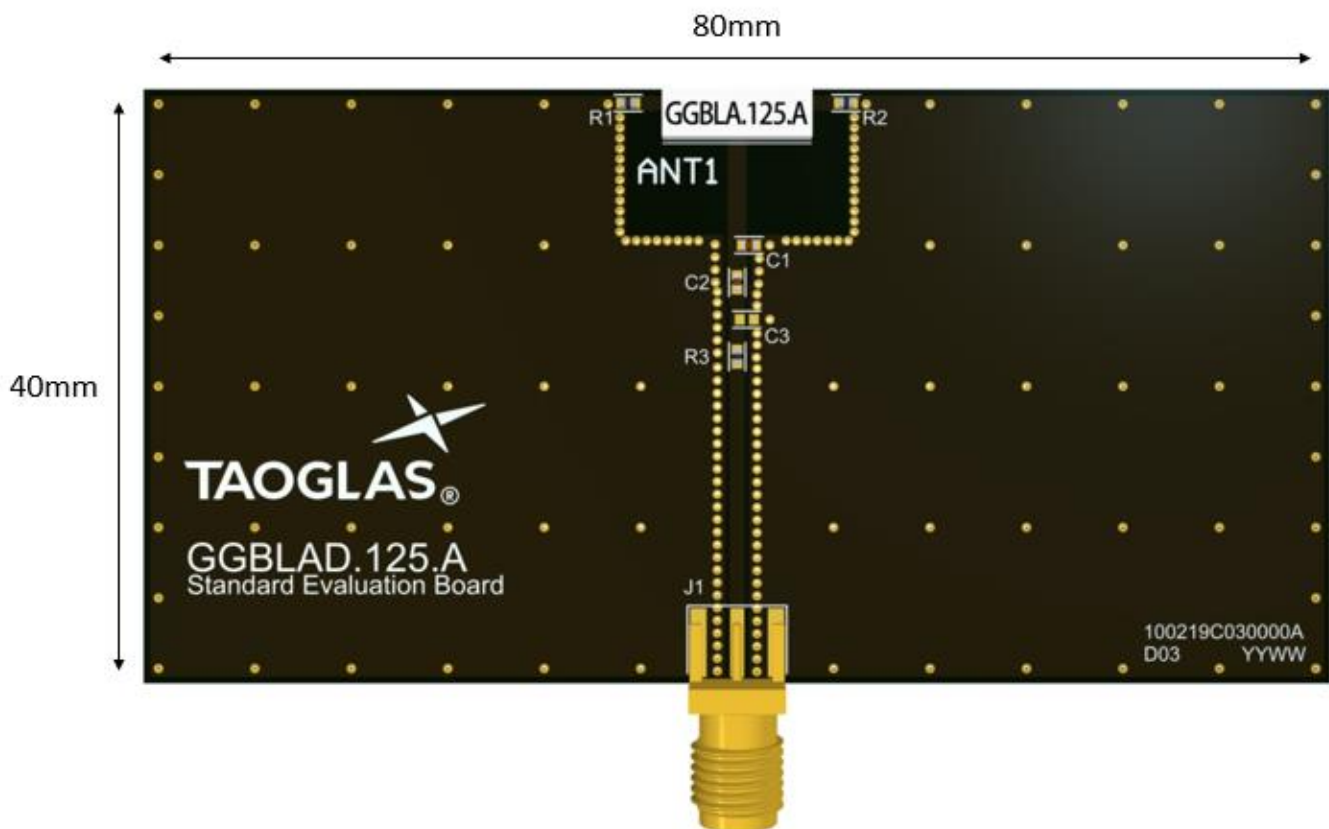

7.6 Matching Circuit

Matching components with the GGBLA.125.A is recommended for the antenna to have optimal performance on the evaluation board. Additional matching components may be necessary for your device, so we recommend incorporating these extra component footprints, forming a matching network, between the radio module and the antenna.

Designator	Type	Value	Manufacturer	Manufacturer Part Number
C1	Capacitor	1.2pF	Murata	GRM1555C1H1R2CA01D
C2	Capacitor	3.9pF	Murata	GRM1555C1H3R9CA01D
C3	Capacitor	Not Fitted	-	-
R1, R2, R3	Resistor	0 Ohms	Yageo	RC0402JR-070RL

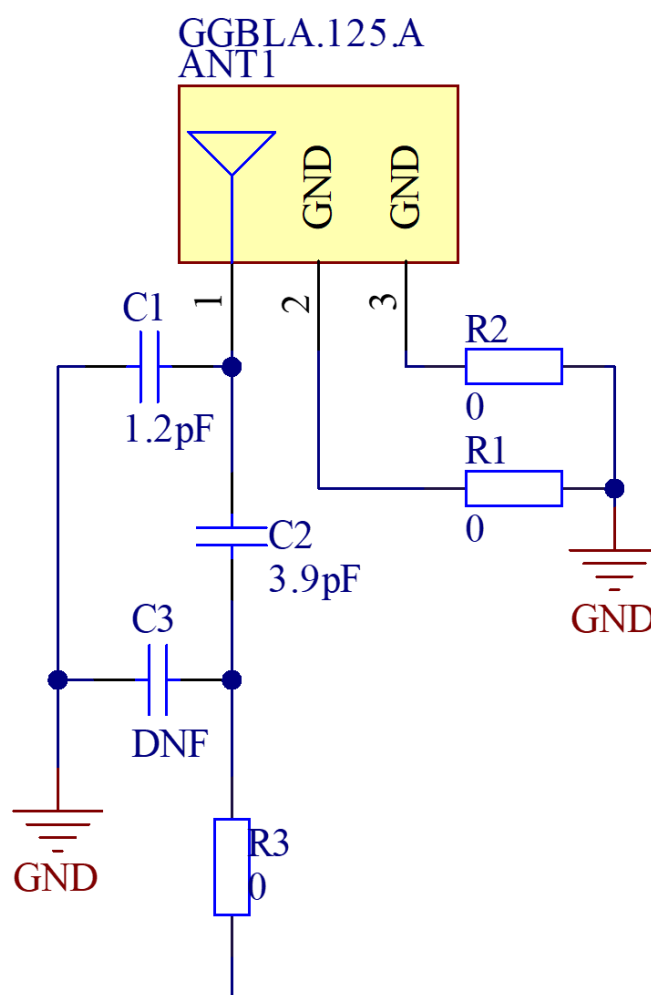

7.7 Footprint

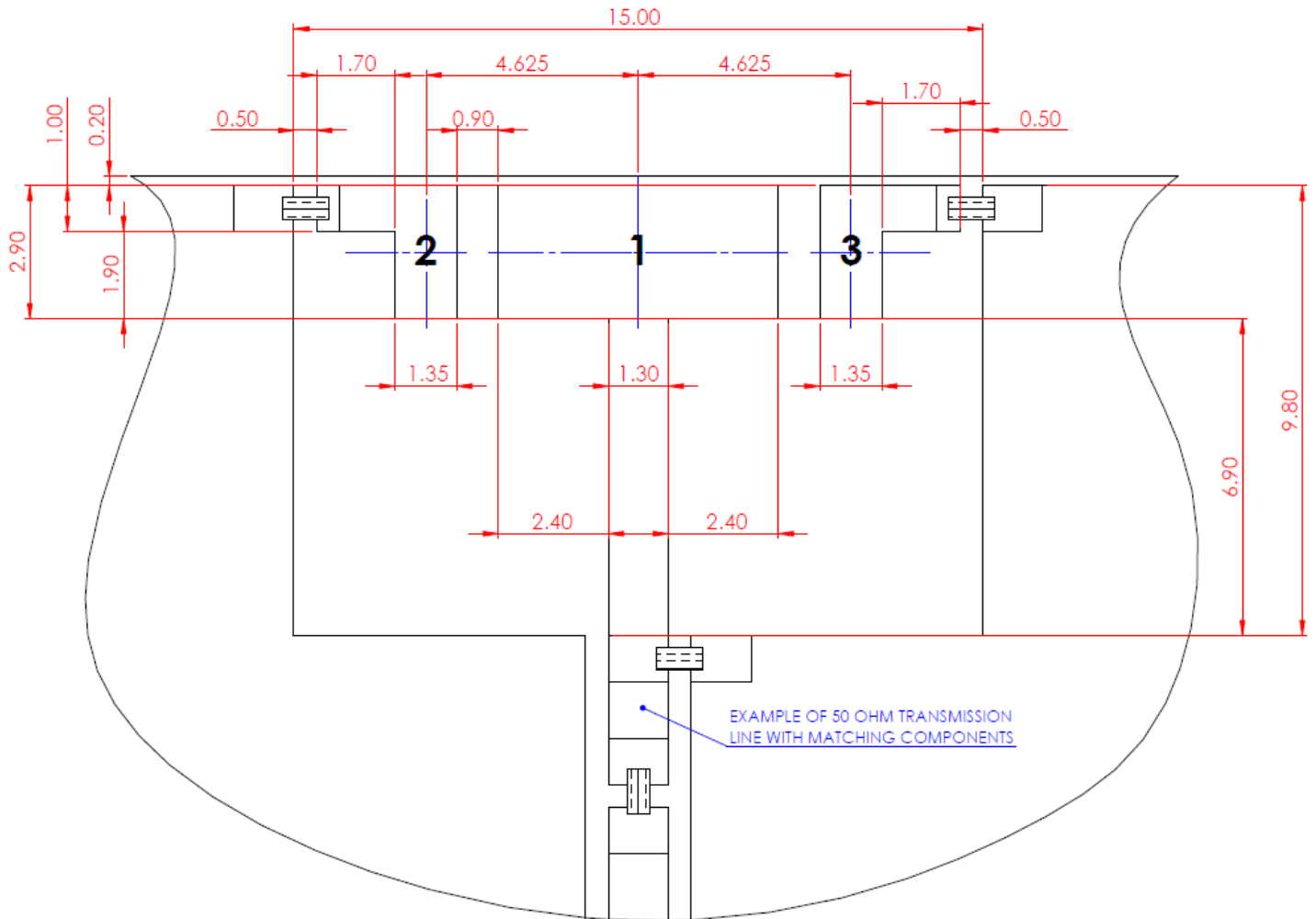

<u>PIN:</u>	<u>DESCRIPTION:</u>
1	Feed (50 ohm)
2,3	Ground

8. Packaging

1000pcs GGBLA.125.A per Tape & Reel
 Dimensions - $\varnothing 330 \times 28.4$
 Weight - 700g



1000pcs GGBLA.125.A per carton
 Dimensions - $350 \times 340 \times 47$ mm
 Weight - 900g

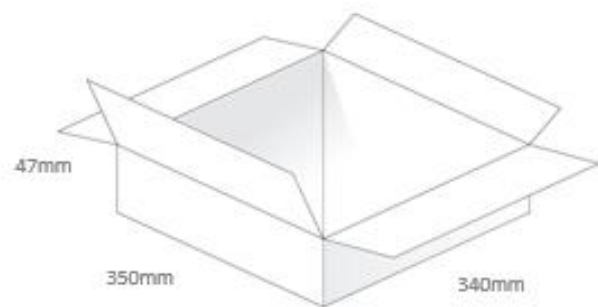

5000pcs GGBLA.125.A per carton
 Dimensions - $360 \times 370 \times 275$ mm
 Weight - 5.3Kg

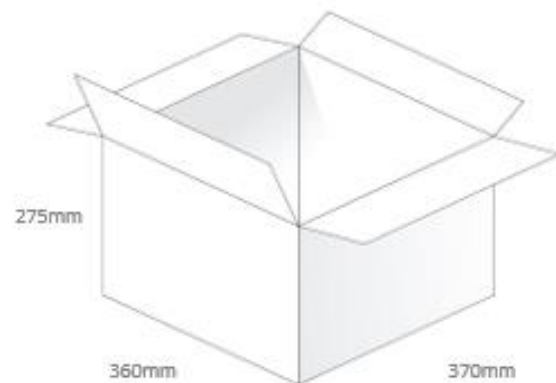

Pallet Dimensions:
 $1100 \times 1100 \times 1300$ mm
 36 Cartons Per Pallet
 9 Cartons Per Layer, 4 Layers

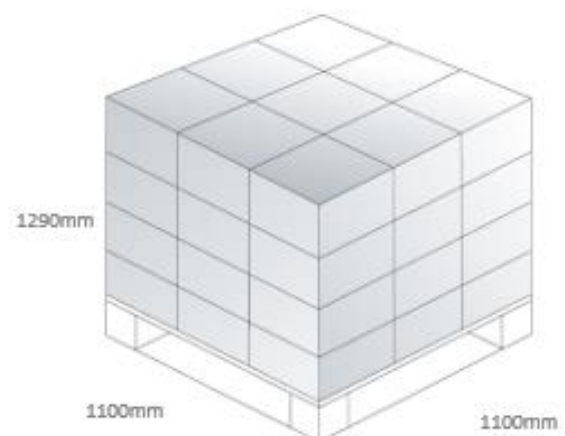

Changelog for the datasheet

SPE-19-8-045 – GGBLA.125.A

Revision: I (Current Version)

Date:	2023-07-25
Changes:	Updated Field Test Results
Changes Made by:	Gary West

Previous Revisions

Revision: H

Date:	2023-02-14
Changes:	Added L Band to spec table and updated antenna integration guide.
Changes Made by:	Gary West

Revision: C

Date:	2020-03-18
Changes:	Modified RTK Table
Changes Made by:	Yu Kai Yeung

Revision: G

Date:	2022-05-11
Changes:	Updated Packaging Specifications
Changes Made by:	Paul Doyle

Revision: B

Date:	2019-12-08
Changes:	Added GNSS Frequency Matrix and RTK Data
Changes Made by:	Yu Kai Yeung

Revision: F

Date:	2021-09-09
Changes:	Added MSL rating, updated frontpage font.
Changes Made by:	Erik Landi

Revision: A (Original First Release)

Date:	2019-04-04
Notes:	Initial Specification Release
Author:	Yu Kai Yeung

Revision: E

Date:	2021-05-06
Changes:	Added L6 band to spec table.
Changes Made by:	Gary West

Revision: D

Date:	2020-06-04
Changes:	Added Field Test Results
Changes Made by:	Victor Pinazo



www.taoglas.com

