

- 1
- 2
- 3
- 4
- 5
- 6
- 7
- 8
- 9
- 10
- 11
- 12
- 13
- 14
- 15
- 16
- 17
- 18

MATERIAL

Glass-fibre reinforced polyamide based (PA) technopolymer, black colour, matte finish.

STANDARD EXECUTIONS

- **GC-A:** zinc-plated steel M8 cylindrical-head screws with hexagon socket and nuts.
- **GC-SST:** AISI 304 stainless steel M8 cylindrical-head screws with hexagon socket and nuts.

FEATURES

Maximum tightening torque for screw assembly 19 Nm.

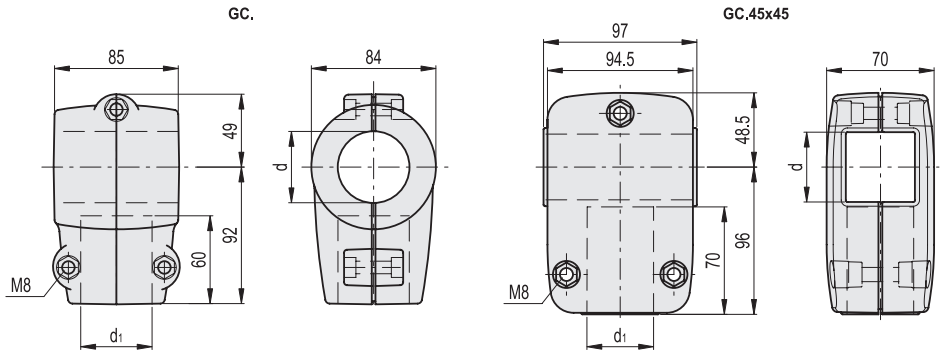

Conversion Table
1 mm = 0.039 inch

mm	inch
42.4	1.67
48.3	1.90
60.3	2.37
45x45	1.77x1.77

GC.

METRIC

Code	Description	d Tube (mm)	d Tube (GAS)	d1 Tube (mm)	d1 Tube (GAS)	△△
419646	GC.42-42-A	42.4	1"1/4	42.4	1"1/4	410
419644	GC.48-42-A	48.3	1"1/2	42.4	1"1/4	400
419642	GC.48-48-A	48.3	1"1/2	48.3	1"1/2	390
419640	GC.60-42-A	60.3	2"	42.4	1"1/4	380
419638	GC.60-48-A	60.3	2"	48.3	1"1/2	370
419661	GC.45x45-A	45x45	-	45x45	-	387

GC-SST

INOX STAINLESS STEEL METRIC

Code	Description	d Tube (mm)	d Tube (GAS)	d1 Tube (mm)	d1 Tube (GAS)	△△
419647	GC.42-42-SST	42.4	1"1/4	42.4	1"1/4	410
419645	GC.48-42-SST	48.3	1"1/2	42.4	1"1/4	400
419643	GC.48-48-SST	48.3	1"1/2	48.3	1"1/2	390
419641	GC.60-42-SST	60.3	2"	42.4	1"1/4	380
419639	GC.60-48-SST	60.3	2"	48.3	1"1/2	370
419662	GC.45x45-SST	45x45	-	45x45	-	387

Levelling elements and supports