

REVISIONS					
REV	ECO	DESCRIPTION	DATE	BY	APPR
A1	--	FIRST RELEASED	NOV-23-2021	BLINK	TOMMY
A2	--	ADD IP68	APR-26-2023	JUN	TOMMY
A3	--	UPDATED SUITABLE CONTACT NOTE	MAY-16-2023	RO	RO

MASTER KEYWAY

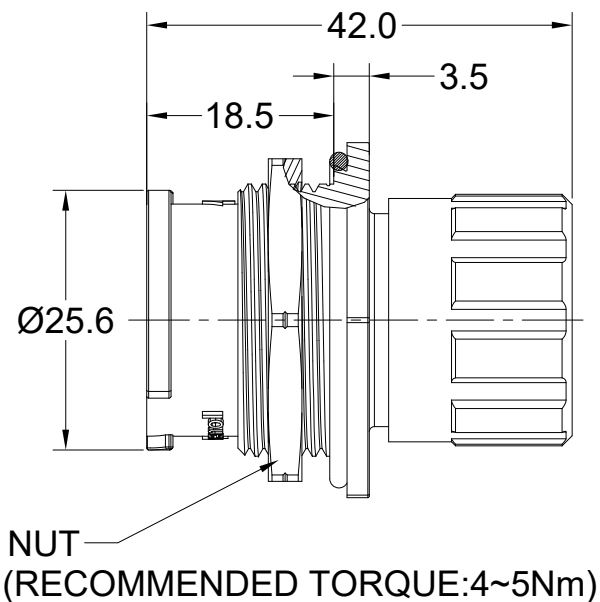
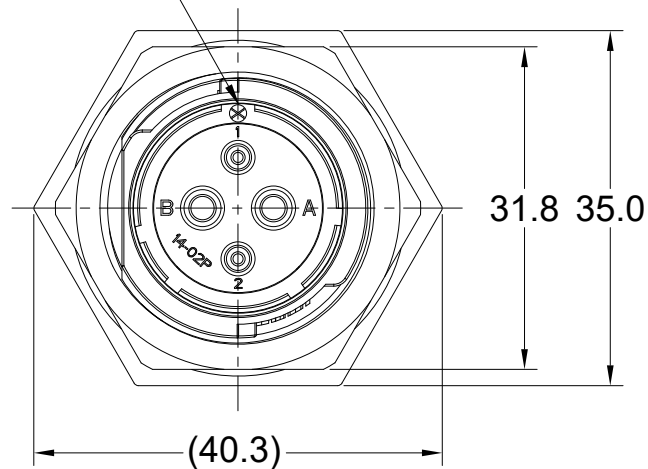

NOTES: (UNLESS OTHERWISE SPECIFIED)

1. MATERIAL:

- SHELL: THERMOPLASTIC, BLACK, UL94 V-0.
- INSERT: THERMOPLASTIC, BLACK, UL94 V-0.
- O-RING: SILICONE RUBBER, BLACK.
- END CAP: THERMOPLASTIC, BLACK, UL94 V-0.
- PLASTIC RING:THERMOPLASTIC, BLACK, UL94 V-0.
- WIRE SEAL: SILICONE RUBBER, RED.
- JAM NUT: ALUMINIUM ALLOY, BLACK ANODIZING.

2. SPECIFICATIONS:

- 2.1 RATED CURRENT: SEE TABLE 2.
- 2.2 RATED VOLTAGE: SEE TABLE 2.
- 2.3 OPERATING TEMPERATURE: -40°C~125°C.
- 2.4 DIELECTRIC WITHSTANDING VOLTAGE: SEE TABLE 1.
- 2.5 INSULATION RESISTANCE: 5000 MEGOHMS MIN.
- 2.6 IP--CLASS: IP67,IP68 AND IP69K IN MATED CONDITION.
- 2.7 MATING CYCLES DURABILITY: 500 CYCLES MIN.
- 2.8 RoHS COMPLIANT.

3. SUITABLE CONTACTS : SEE TABLE 2.

4. ALL DIMENSIONS ARE FOR REFERENCE USE ONLY.

5. CONTACT SIZE AND REAR SEAL WIRE RANGE :

CONTACT SIZE	MIN. INSUL O.D.	MAX. INSUL O.D.	WIRE RANGE
8#	Ø2.8mm	Ø5.2mm	10 - 12AWG
2.5mm	Ø3.3mm	Ø4.3mm	4mm²&12 - 14AWG
16#	Ø2.0mm	Ø3.2mm	14 - 24AWG
20#	Ø1.4mm	Ø2.1mm	20 - 30AWG

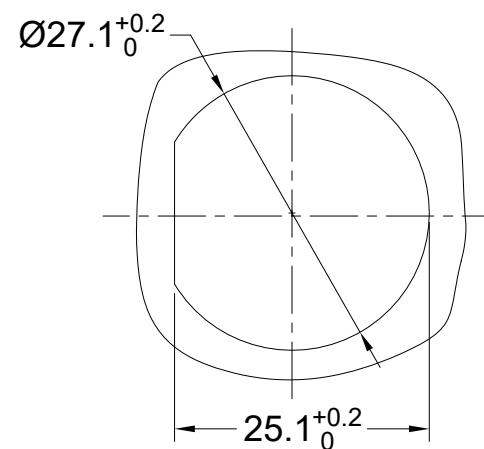

RECOMMENDED PANEL MOUNTING HOLE

RECOMMENDED PANEL THICKNESS 5.0MM MAX

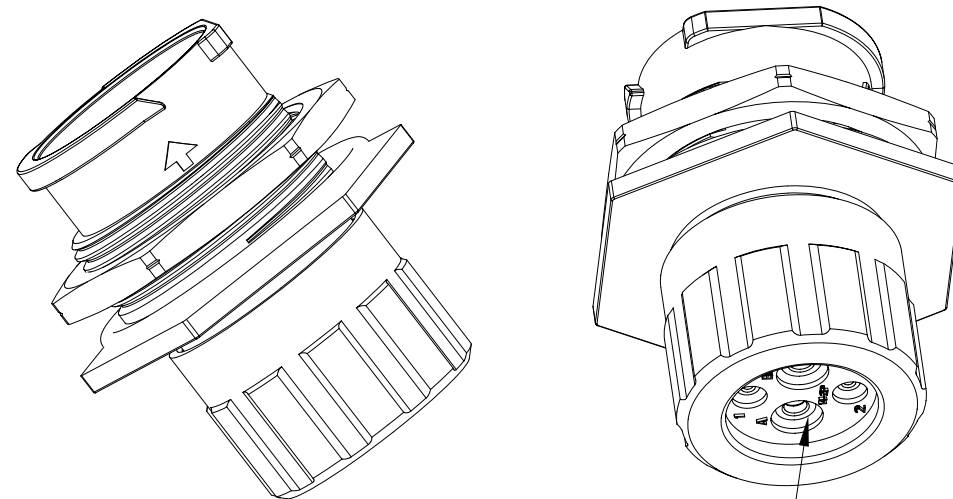

SEALING PLUGS CAN BE PURCHASED SEPARATELY

QUANTITY	PART NUMBER	DESCRIPTION	ITEM
MATERIALS LIST			
UNLESS OTHERWISE SPECIFIED 1) All dimensions are in metric(mm). 2) Tolerances are as follows: 1 PL DEC ±0.30 2 PL DEC ±0.15 3 PL DEC ±0.08 Fractions ±1/64 Angles ±1° 3) Note reference =		SIGNATURES DRAWN: JUN APR-26-2023 CHECKED: JOE APR-28-2023 ENGINEER: APPROVAL: TOMMY MAY-02-2023	DATE
MATERIAL SPECIFICATIONS:		CUSTOMER:	
PROCESS SPECIFICATIONS:		THIS DRAWING IS SUPPLIED FOR INFORMATION ONLY. DESIGN FEATURES, SPECIFICATIONS AND PERFORMANCE DATA SHOWN HEREON ARE THE PROPERTY OF THE AMPHENOL CORPORATION. NO RIGHTS OF REPRODUCTION ARE IMPLIED. ALL DIMENSIONS ARE SUBJECT TO NORMAL MANUFACTURING VARIATIONS.	
NEXT ASSY:		SIZE: B TYPE: C- DWG NO.: FLS714xxxPHEC03 REVISION: A3	
		SCALE: NONE	SHEET 1 OF 4

TITLE: EcoMate Aquarius,RECEPTACLE, JAMNUT, xx POSITION, MALE SHELL SIZE 14, END CAP

DWG NO.:

FLS714xxxPHEC03

REV: A3

SH: 1

OF: 1

REVISIONS					
REV	ECO	DESCRIPTION	DATE	BY	APPR
A1	--	FIRST RELEASED	NOV-23-2021	BLINK	TOMMY
A2	--	ADD IP68	APR-26-2023	JUN	TOMMY
A3	--	UPDATED SUITABLE CONTACT NOTE	MAY-16-2023	RO	RO

FLS714xxxPHEC03

PROTECTION KEY:(SEE TABLE 1):
 N KEY(STANADRD VERSION)
 W KEY
 X KEY
 Y KEY
 Z KEY

STANDS FOR INSERT ARRANGEMENT:
 2 - 4(2+2) CORES.
 3 - 3 CORES.
 4 - 4 CORES.
 8 - 8 CORES.
 12 - 12 CORES.
 19 - 19 CORES.

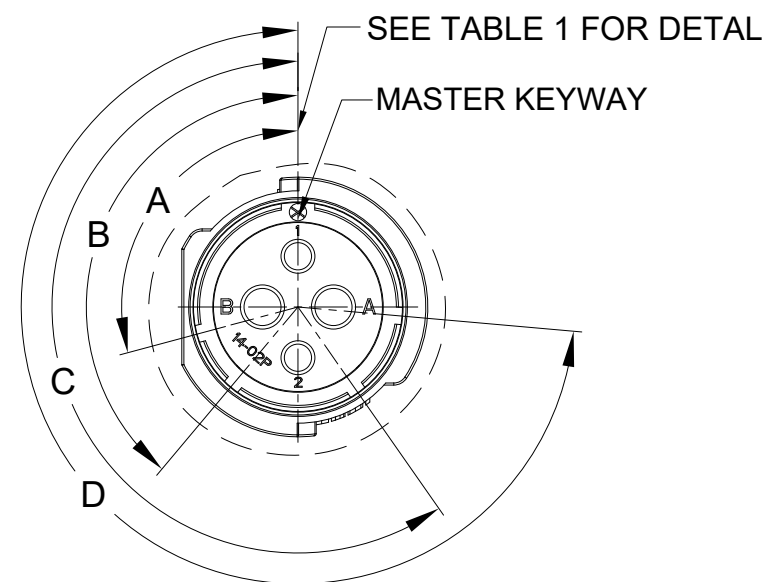

TABLE 1:

KEY POS	A	B	C	D
N	105°	140°	215°	265°
W	60°	140°	215°	265°
X	105°	160°	215°	265°
Y	105°	140°	225°	265°
Z	105°	140°	215°	295°

QUANTITY	PART NUMBER	DESCRIPTION	ITEM
MATERIALS LIST			
UNLESS OTHERWISE SPECIFIED 1) All dimensions are in metric(mm). 2) Tolerances are as follows: 1 PL DEC ±0.30 2 PL DEC ±0.15 3 PL DEC ±0.08 Fractions ±1/64 Angles ±1° 3) Note reference = X		Amphenol Sine Systems - www.amphenol-sine.com 44724 Morley Drive Clinton Township, MI 48036	
MATERIAL SPECIFICATIONS: PROCESS SPECIFICATIONS: NEXT ASSY:		SIGNATURES DATE DRAWN: JUN APR-26-2023 CHECKED: JOE APR-28-2023 ENGINEER: APPROVAL: TOMMY MAY-02-2023 CUSTOMER: THIS DRAWING IS SUPPLIED FOR INFORMATION ONLY. DESIGN FEATURES, SPECIFICATIONS AND PERFORMANCE DATA SHOWN HEREON ARE THE PROPERTY OF THE AMPHENOL CORPORATION. NO RIGHTS OF REPRODUCTION ARE IMPLIED. ALL DIMENSIONS ARE SUBJECT TO NORMAL MANUFACTURING VARIATIONS.	
		SIZE TYPE DWG NO. REVISION B C- FLS714xxxPHEC03 A3	
		SCALE: NONE	SHEET 2 OF 4

TITLE: EcoMate Aquarius,RECEPTACLE, JAM NUT, xx POSITION, MALE,SHELL SIZE 14,END CAP

DWG NO:

FLS714xxxPHEC03

REV: A3

SH: 1

OF: 1

REVISIONS					
REV	ECO	DESCRIPTION	DATE	BY	APPR
A1	--	FIRST RELEASED	NOV-23-2021	BLINK	TOMMY
A2	--	ADD IP68	APR-26-2023	JUN	TOMMY
A3	--	UPDATED SUITABLE CONTACT NOTE	MAY-16-2023	RO	RO

TABLE 2:

PART NUMBER	FLS714x3PHEC03	FLS714x4PHEC03	FLS714x2PHEC03	FLS714x8PHEC03	FLS714x12PHEC03	FLS714x19PHEC03
MALE INSERT ARRANGEMENT FRONT VIEW						
MALE INSERT ARRANGEMENT REAR VIEW						
SUITABLE CONTACTS	3 x Size 8 (3.6mm ²)	4 x Size 12 (2.5mm ²)	2 x Size 16 (1.5mm ²) 2 x Size 12 (2.5mm ²)	8 x Size 16 (1.5mm ²)	12 x Size 16 (2.0mm ²)	20 x Size 14 (1.4mm ²)
RATED CURRENT	45A	25A-MACHINED CONT. 23A-STAMPED CONT.	(2.5mm) 25A-MACHINED CONT. (2.5mm) 23A-STAMPED CONT. (16#)13A	13A	13A	7.5A-MACHINED CONT. 5A-STAMPED CONT.
RATED VOLTAGE	600V AC/DC	500V AC/DC	500V AC/DC	500V AC/DC	500V AC/DC	250V AC/DC
DIELECTRIC WITHSTANDING VOLTAGE	2200V AC	2000V AC	2000V AC	2000V AC	2000V AC	1500V AC

TITLE: EcoMate Aquarius, RECEPTACLE, JAM NUT, xx POSITION, MALE SHELL SIZE 14, END CAP

DWG NO.: FLS714xxxPHEC03

REV: A3

SH: 1

OF: 1

QUANTITY	PART NUMBER	DESCRIPTION	ITEM
MATERIALS LIST			
UNLESS OTHERWISE SPECIFIED 1) All dimensions are in metric(mm). 2) Tolerances are as follows: 1 PL DEC ±0.30 2 PL DEC ±0.15 3 PL DEC ±0.08 3) Note reference =		SIGNATURES DATE DRAWN: JUN APR-26-2023 CHECKED: JOE APR-28-2023 ENGINEER: APPROVAL: TOMMY MAY-02-2023	
MATERIAL SPECIFICATIONS:		CUSTOMER:	
PROCESS SPECIFICATIONS:		THIS DRAWING IS SUPPLIED FOR INFORMATION ONLY. DESIGN FEATURES, SPECIFICATIONS AND PERFORMANCE DATA SHOWN HEREON ARE THE PROPERTY OF THE AMPHENOL CORPORATION. NO RIGHTS OF REPRODUCTION ARE IMPLIED. ALL DIMENSIONS ARE SUBJECT TO NORMAL MANUFACTURING VARIATIONS.	
NEXT ASSY:		EcoMate Aquarius, RECEPTACLE, JAM NUT, xx POSITION, MALE, SHELL SIZE 14, END CAP	
SIZE	TYPE	DWG NO.	REVISION
B	C-	FLS714xxxPHEC03	A3
SCALE:	NONE	SHEET	3 OF 4

ecomate® RM/RSSM/Aquarius™ - Contact Size 20 Options

Machined, Crimp Contacts				
Part Number		Contact Size (AWG)	Wire Range (mm ²)	Plating
Male	Female			
MP20W23F	MS20W23F	22-20AWG	0.34-0.50 mm ²	Gold Flash
MP20W23G5	MS20W23G5	22-20AWG	0.34-0.50 mm ²	Gold 5μ"
MP20W23G10	MS20W23G10	22-20AWG	0.34-0.50 mm ²	Gold 10μ"
MP20W23G15	MS20W23G15	22-20AWG	0.34-0.50 mm ²	Gold 15μ"
MP20W23G30	MS20W23G30	22-20AWG	0.34-0.50 mm ²	Gold 30μ"
MP24W23F	MS24W23F	26-24AWG	0.14-0.25 mm ²	Gold Flash
MP24W23G5	MS24W23G5	26-24AWG	0.14-0.25 mm ²	Gold 5μ"
MP24W23G10	MS24W23G10	26-24AWG	0.14-0.25 mm ²	Gold 10μ"
MP24W23G15	MS24W23G15	26-24AWG	0.14-0.25 mm ²	Gold 15μ"
MP24W23G30	MS24W23G30	26-24AWG	0.14-0.25 mm ²	Gold 30μ"
MP28W23F	MS28W23F	30-28AWG	0.05-0.08 mm ²	Gold Flash
MP28W23G5	MS28W23G5	30-28AWG	0.05-0.08 mm ²	Gold 5μ"
MP28W23G10	MS28W23G10	30-28AWG	0.05-0.08 mm ²	Gold 10μ"
MP28W23G15	MS28W23G15	30-28AWG	0.05-0.08 mm ²	Gold 15μ"
MP28W23G30	MS28W23G30	30-28AWG	0.05-0.08 mm ²	Gold 30μ"

Stamped & Formed, Crimp Contacts				
Part Number		Contact Size (AWG)	Wire Range (mm ²)	Plating
Male	Female			
SP20W2F	SS20W2F	22-20AWG	0.34-0.50 mm ²	Gold Flash
SP20W2G5	SS20W2G5	22-20AWG	0.34-0.50 mm ²	Gold 5μ"
SP20W2G10	SS20W2G10	22-20AWG	0.34-0.50 mm ²	Gold 10μ"
SP20W2G15	SS20W2G15	22-20AWG	0.34-0.50 mm ²	Gold 15μ"
SP20W2G30	SS20W2G30	22-20AWG	0.34-0.50 mm ²	Gold 30μ"
SP24W2F	SS24W2F	26-24AWG	0.14-0.25 mm ²	Gold Flash
SP24W2G5	SS24W2G5	26-24AWG	0.14-0.25 mm ²	Gold 5μ"
SP24W2G10	SS24W2G10	26-24AWG	0.14-0.25 mm ²	Gold 10μ"
SP24W2G15	SS24W2G15	26-24AWG	0.14-0.25 mm ²	Gold 15μ"
SP24W2G30	SS24W2G30	26-24AWG	0.14-0.25 mm ²	Gold 30μ"
SP28W2F	SS28W2F	30-28AWG	0.05-0.08 mm ²	Gold Flash
SP28W2G5	SS28W2G5	30-28AWG	0.05-0.08 mm ²	Gold 5μ"
SP28W2G10	SS28W2G10	30-28AWG	0.05-0.08 mm ²	Gold 10μ"
SP28W2G15	SS28W2G15	30-28AWG	0.05-0.08 mm ²	Gold 15μ"
SP28W2G30	SS28W2G30	30-28AWG	0.05-0.08 mm ²	Gold 30μ"

Machined, Tooling	
Part Number	Description
QXRT20	Contact Extraction Tool, #20 (Ø 1.0) Contact
MFX-3959	Hand Crimp Tool for Machined Contacts
MFX-3960	Pneumatic Crimp Tool for Machined Contact

Stamped & Formed, Tooling	
Part Number	Description
QXRT20	Contact Extraction Tool, #20 (Ø 1.0) Contact
MFX-3958	Hand Tool, Stamped & Formed Contact, Size 20, 20-28AWG
MFX-3957	Crimp Die for Stamped & Formed Contact

Plating Options, All	
Symbol	Plating
T	Tin Plated (for Stamped & Formed Contacts)
S	Silver Plated 5Um (for Machined Contacts)
F	Gold Plated
G5	Gold Plated (Thickness 5μ")
G10	Gold Plated (Thickness 10μ")
G15	Gold Plated (Thickness 15μ")
G30	Gold Plated (Thickness 30μ")

Misc Tooling, All	
Part Number	Description
CA-4020-59	Sealing Plug, Size 16 & 20

Standard Quantity Order Options	
Machined	Bulk Package, 500 Pieces
Stamped & Formed	Reel, 3000 Pieces