

REVISIONS					
REV	ECO	DESCRIPTION	DATE	BY	APPR
A1	--	FIRST RELEASED	NOV-23-2021	BLINK	TOMMY
A2	--	ADD IP68	APR-26-2023	JUN	TOMMY
A3	--	UPDATEDS SUITABLE CONTACT NOTE	MAY-16-2023	RO	RO

MASTER KEYWAY

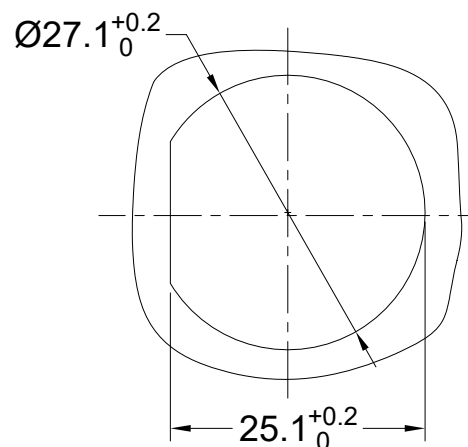
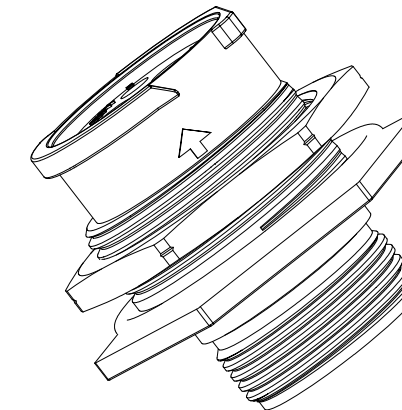
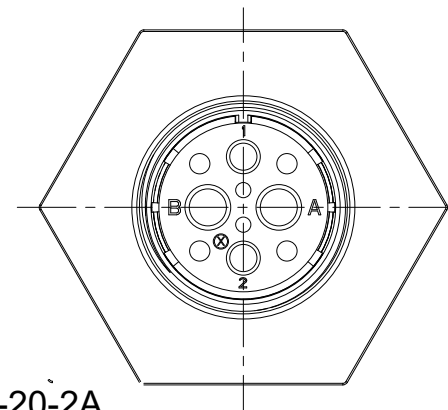
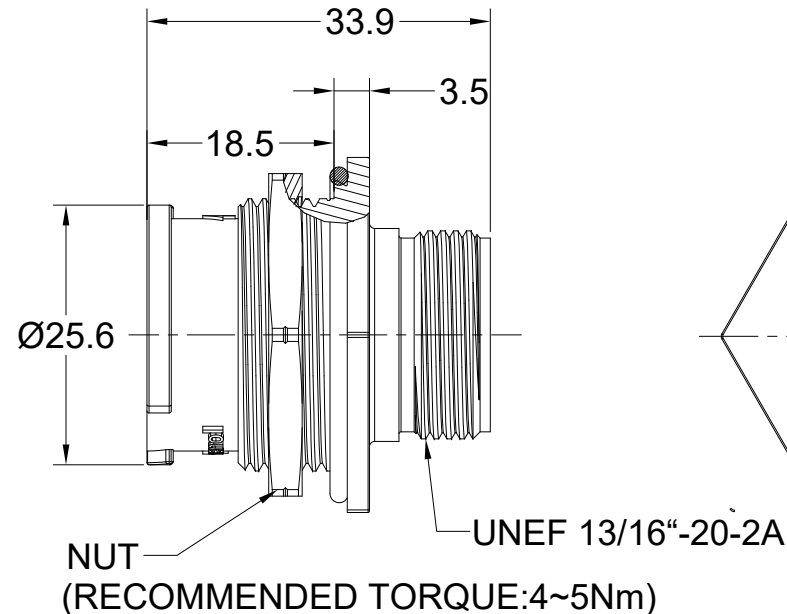
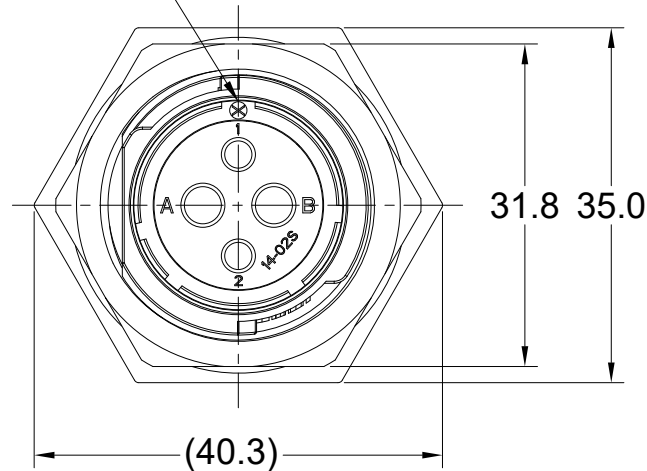

RECOMMENDED PANEL MOUNTING HOLE

RECOMMENDED PANEL THICKNESS 5.0MM MAX

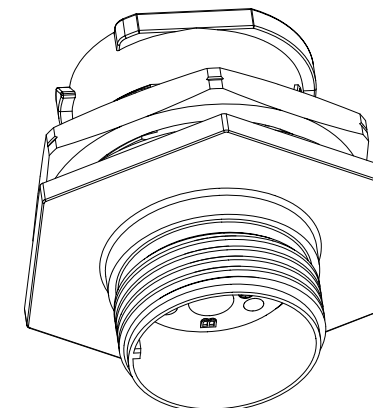

NOTES: (UNLESS OTHERWISE SPECIFIED)

- MATERIAL:
 - SHELL: THERMOPLASTIC, BLACK, UL94 V-0.
 - INSERT: THERMOPLASTIC, BLACK, UL94 V-0.
 - O-RING: SILICONE RUBBER, BLACK.
 - JAM NUT: ALUMINIUM ALLOY, BLACK ANODIZING.
- SPECIFICATIONS:
 - 2.1 RATED CURRENT: SEE TABLE 2.
 - 2.2 RATED VOLTAGE: SEE TABLE 2.
 - 2.3 OPERATING TEMPERATURE: -40°C~125°C.
 - 2.4 DIELECTRIC WITHSTANDING VOLTAGE: SEE TABLE 1.
 - 2.5 INSULATION RESISTANCE: 5000 MEGOHMS MIN.
 - 2.6 IP--CLASS: IP67,IP68 AND IP69K IN MATED CONDITION.
 - 2.7 MATING CYCLES DURABILITY: 500 CYCLES MIN.
 - 2.8 RoHS COMPLIANT.
- SUITABLE CONTACTS : SEE TABLE 2.
- ALL DIMENSIONS ARE FOR REFERENCE USE ONLY.

QUANTITY	PART NUMBER	DESCRIPTION	ITEM
MATERIALS LIST			
UNLESS OTHERWISE SPECIFIED		<h1>Amphenol</h1> <p>Sine Systems - www.amphenol-sine.com 44724 Morley Drive Clinton Township, MI 48036</p> <p>EcoMate Aquarius.RECEPTACLE, JAM NUT, xx POSITION, FEMALE,SHELL SIZE 14</p>	
1) All dimensions are in metric(mm).			
2) Tolerances are as follows:			
3) Note reference =			
SIGNATURES		DATE	
DRAWN: JUN		APR-26-2023	
CHECKED: JOE		APR-28-2023	
ENGINEER:			
APPROVAL: TOMMY		MAY-02-2023	
MATERIAL SPECIFICATIONS:		CUSTOMER:	
PROCESS SPECIFICATIONS:		THIS DRAWING IS SUPPLIED FOR INFORMATION ONLY. DESIGN FEATURES, SPECIFICATIONS AND PERFORMANCE DATA SHOWN HEREON ARE THE PROPERTY OF THE AMPHENOL CORPORATION. NO RIGHTS OF REPRODUCTION ARE IMPLIED. ALL DIMENSIONS ARE SUBJECT TO NORMAL MANUFACTURING VARIATIONS.	
NEXT ASSY:			
SIZE	TYPE	DWG NO.	REVISION
B	C-	FLS714xxxS03	A3
SCALE:	NONE	SHEET	1 OF 4

TITLE: EcoMate Aquarius.RECEPTACLE, JAM NUT, xx POSITION, FEMALE,SHELL SIZE 14
DWG NO.: FLS714xxxS03
REV: A3
SH: 1
OF: 3

REVISIONS					
REV	ECO	DESCRIPTION	DATE	BY	APPR
A1	--	FIRST RELEASED	NOV-23-2021	BLINK	TOMMY
A2	--	ADD IP68	APR-26-2023	JUN	TOMMY
A3	--	UPDATEDS SUITABLE CONTACT NOTE	MAY-16-2023	RO	RO

ORDERING INFORMATION:

FLS712xxxP03

PROTECTION KEY:(SEE TABLE 1):
N KEY(STANADRD VERSION)

W KEY
X KEY
Y KEY
Z KEY

STANDS FOR INSERT ARRANGEMENT:

2 - 4(2+2) CORES.
3 - 3 CORES.
4 - 4 CORES.
7 - 7 CORES.
8 - 8 CORES.
12 - 12 CORES.
19 - 19 CORES.

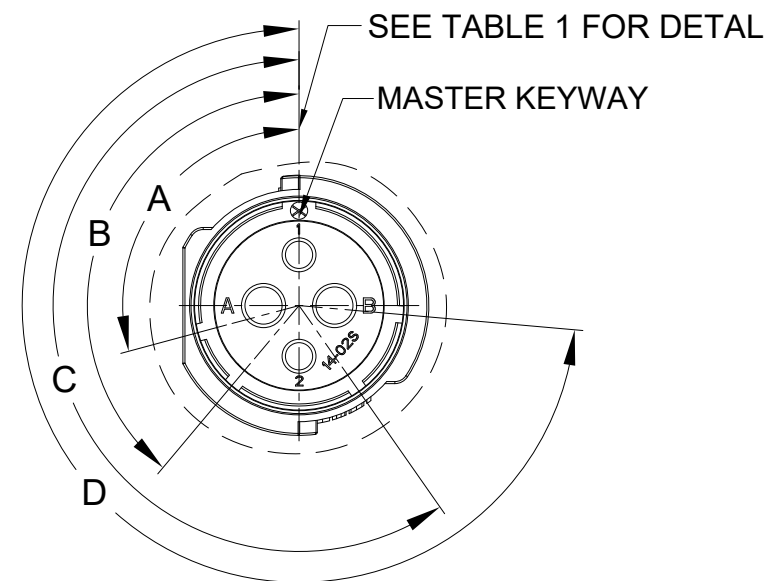

TABLE 1:

KEY POS	A	B	C	D
N	105°	140°	215°	265°
W	60°	140°	215°	265°
X	105°	160°	215°	265°
Y	105°	140°	225°	265°
Z	105°	140°	215°	295°

QUANTITY	PART NUMBER	DESCRIPTION	ITEM
MATERIALS LIST			
<small>UNLESS OTHERWISE SPECIFIED</small> 1) All dimensions are in metric(mm). 2) Tolerances are as follows: 1 PL DEC ±0.30 2 PL DEC ±0.15 3 PL DEC ±0.08 Fractions ±1/64 Angles ±1° 3) Note reference = \triangle X		SIGNATURES DATE DRAWN: JUN APR-26-2023 CHECKED: JOE APR-28-2023 ENGINEER: APPROVAL: TOMMY MAY-02-2023 CUSTOMER:	
<small>MATERIAL SPECIFICATIONS:</small> <small>PROCESS SPECIFICATIONS:</small> <small>NEXT ASSY:</small>		<div style="text-align: center;"> <h1>Amphenol</h1> <p>Sine Systems - www.amphenol-sine.com 44724 Morley Drive Clinton Township, MI 48036</p> </div> <div style="text-align: center;"> <p>EcoMate Aquarius,RECEPTACLE, JAM NUT, xx POSITION, FEMALE,SHELL SIZE 14</p> </div>	
		<small>SIZE</small> <small>TYPE</small> <small>DWG NO.</small> B C- FLS714xxxS03	<small>REVISION</small> A3
		<small>SCALE:</small> NONE	<small>SHEET</small> 2 <small>OF</small> 4

TITLE: EcoMate Aquarius,RECEPTACLE, JAM NUT, xx POSITION, FEMALE,SHELL SIZE 14
DWG NO.: FLS714xxxS03
REV: A3
SH: 2
OF: 3

REVISIONS					
REV	ECO	DESCRIPTION	DATE	BY	APPR
A1	--	FIRST RELEASED	NOV-23-2021	BLINK	TOMMY
A2	--	ADD IP68	APR-26-2023	JUN	TOMMY
A3	--	UPDATEDS SUITABLE CONTACT NOTE	MAY-16-2023	RO	RO

TABLE 2:

PART NUMBER	FLS714x3S03	FLS714x4S03	FLS714x2S03	FLS714x7S03	FLS714x8S03
FEMALE INSERT ARRANGEMENT FRONT VIEW					
SUITABLE CONTACTS	3 x Size 8 (3.6mm ²)	4 x Size 12 (2.5mm ²)	2 x Size 16 (1.5mm ²) 2 x Size 12 (2.5mm ²)	7 x Size 16 (1.5mm ²)	8 x Size 16 (1.5mm ²)
RATED CURRENT	45A	25A-MACHINED CONT. 23A-STAMPED CONT.	(2.5mm) 25A-MACHINED CONT. (2.5mm) 23A-STAMPED CONT. (16#)13A	13A	13A
RATED VOLTAGE	600V AC/DC	500V AC/DC	500V AC/DC	500V AC/DC	500V AC/DC
DIELECTRIC WITHSTANDING VOLTAGE	2200V AC	2000V AC	2000V AC	2000V AC	2000V AC

PART NUMBER	FLS714x12S03	FLS714x19S03
FEMALE INSERT ARRANGEMENT FRONT VIEW		
SUITABLE CONTACTS	12 x Size 16	19 x Size 20
RATED CURRENT	13A	7.5A-MACHINED CONT. 5A-STAMPED CONT.
RATED VOLTAGE	500V AC/DC	250V AC/DC
DIELECTRIC WITHSTANDING VOLTAGE	2000V AC	1500V AC

QUANTITY	PART NUMBER	DESCRIPTION	ITEM
MATERIALS LIST			
UNLESS OTHERWISE SPECIFIED		SIGNATURES DATE	
1) All dimensions are in metric(mm).		DRAWN: JUN	APR-26-2023
2) Tolerances are as follows:		CHECKED: JOE	APR-28-2023
1 PL DEC ±0.30		ENGINEER:	
2 PL DEC ±0.15		APPROVAL: TOMMY	MAY-02-2023
3 PL DEC ±0.08		CUSTOMER:	
3) Note reference =		THIS DRAWING IS SUPPLIED FOR INFORMATION ONLY. DESIGN FEATURES, SPECIFICATIONS AND PERFORMANCE DATA SHOWN HEREON ARE THE PROPERTY OF THE AMPHENOL CORPORATION. NO RIGHTS OF REPRODUCTION ARE IMPLIED. ALL DIMENSIONS ARE SUBJECT TO NORMAL MANUFACTURING VARIATIONS.	
MATERIAL SPECIFICATIONS:		EcoMate Aquarius,RECEPTACLE, JAM NUT, xx POSITION, FEMALE,SHELL SIZE 14	
PROCESS SPECIFICATIONS:		Sine Systems - www.amphenol-sine.com 44724 Morley Drive Clinton Township, MI 48036	
NEXT ASSY:		SIZE: B TYPE: C- DWG NO: FLS714xxxS03 REVISION: A3	
		SCALE: NONE SHEET 3 OF 4	

TITLE: EcoMate Aquarius,RECEPTACLE, JAM NUT, xx POSITION, FEMALE,SHELL SIZE 14
DWG NO: FLS714xxxS03
REV: A3
SH: 3
OF: 3

ecomate® RM/RSSM/Aquarius™ - Contact Size 16 Options

Machined, Crimp Contacts				
Part Number		Contact Size (AWG)	Wire Range (mm ²)	Plating
Male	Female			
MP14M23F	MS14M23F	14AWG	2.0-2.5mm ²	Gold Flash
MP14M23G5	MS14M23G5	14AWG	2.0-2.5mm ²	Gold 5µ"
MP14M23G10	MS14M23G10	14AWG	2.0-2.5mm ²	Gold 10µ"
MP14M23G15	MS14M23G15	14AWG	2.0-2.5mm ²	Gold 15µ"
MP14M23G30	MS14M23G30	14AWG	2.0-2.5mm ²	Gold 30µ"
MP16M23F	MS16M23F	18-16AWG	0.75-1.5mm ²	Gold Flash
MP16M23G5	MS16M23G5	18-16AWG	0.75-1.5mm ²	Gold 5µ"
MP16M23G10	MS16M23G10	18-16AWG	0.75-1.5mm ²	Gold 10µ"
MP16M23G15	MS16M23G15	18-16AWG	0.75-1.5mm ²	Gold 15µ"
MP16M23G30	MS16M23G30	18-16AWG	0.75-1.5mm ²	Gold 30µ"
MP20M23F	MS20M23F	22-20AWG	0.34-0.50mm ²	Gold Flash
MP20M23G5	MS20M23G5	22-20AWG	0.34-0.50mm ²	Gold 5µ"
MP20M23G10	MS20M23G10	22-20AWG	0.34-0.50mm ²	Gold 10µ"
MP20M23G15	MS20M23G15	22-20AWG	0.34-0.50mm ²	Gold 15µ"
MP20M23G30	MS20M23G30	22-20AWG	0.34-0.50mm ²	Gold 30µ"
MP24M23F	MS24M23F	26-24AWG	0.14-0.25mm ²	Gold Flash
MP24M23G5	MS24M23G5	26-24AWG	0.14-0.25mm ²	Gold 5µ"
MP24M23G10	MS24M23G10	26-24AWG	0.14-0.25mm ²	Gold 10µ"
MP24M23G15	MS24M23G15	26-24AWG	0.14-0.25mm ²	Gold 15µ"
MP24M23G30	MS24M23G30	26-24AWG	0.14-0.25mm ²	Gold 30µ"

Stamped & Formed, Crimp Contacts				
Part Number		Contact Size (AWG)	Wire Range (mm ²)	Plating
Male	Female			
SP14M2F	SS14M2F	14AWG	2.0-2.5mm ²	Gold Flash
SP14M2G5	SS14M2G5	14AWG	2.0-2.5mm ²	Gold 5µ"
SP14M2G10	SS14M2G10	14AWG	2.0-2.5mm ²	Gold 10µ"
SP14M2G15	SS14M2G15	14AWG	2.0-2.5mm ²	Gold 15µ"
SP14M2G30	SS14M2G30	14AWG	2.0-2.5mm ²	Gold 30µ"
SP16M2F	SS16M2F	18-16AWG	0.75-1.5mm ²	Gold Flash
SP16M2G5	SS16M2G5	18-16AWG	0.75-1.5mm ²	Gold 5µ"
SP16M2G10	SS16M2G10	18-16AWG	0.75-1.5mm ²	Gold 10µ"
SP16M2G15	SS16M2G15	18-16AWG	0.75-1.5mm ²	Gold 15µ"
SP16M2G30	SS16M2G30	18-16AWG	0.75-1.5mm ²	Gold 30µ"
SP20M2F	SS20M2F	22-20AWG	0.34-0.50mm ²	Gold Flash
SP20M2G5	SS20M2G5	22-20AWG	0.34-0.50mm ²	Gold 5µ"
SP20M2G10	SS20M2G10	22-20AWG	0.34-0.50mm ²	Gold 10µ"
SP20M2G15	SS20M2G15	22-20AWG	0.34-0.50mm ²	Gold 15µ"
SP20M2G30	SS20M2G30	22-20AWG	0.34-0.50mm ²	Gold 30µ"
SP24M2F	SS24M2F	26-24AWG	0.14-0.25mm ²	Gold Flash
SP24M2G5	SS24M2G5	26-24AWG	0.14-0.25mm ²	Gold 5µ"
SP24M2G10	SS24M2G10	26-24AWG	0.14-0.25mm ²	Gold 10µ"
SP24M2G15	SS24M2G15	26-24AWG	0.14-0.25mm ²	Gold 15µ"
SP24M2G30	SS24M2G30	26-24AWG	0.14-0.25mm ²	Gold 30µ"

Machined, Tooling	
Part Number	Description
QXRT16	Contact Extraction Tool, #16 (Ø 1.6) Contact
MFY-3959	Hand Crimp Tool for Machined Contacts
MFY-3960	Pneumatic Crimp Tool for Machined Contact

Stamped & Formed, Tooling	
Part Number	Description
QXRT16	Contact Extraction Tool, #16 (Ø 1.6) Contact
MFY-3954	Hand Tool, Stamped & Formed Contact, Size 16, 20-14AWG
MFY-3957	Crimp Die, Stamped & Formed Contact

Plating Options, All	
Symbol	Plating
T	Tin Plated (for Stamped & Formed Contacts)
S	Silver Plated 5Um (for Machined Contacts)
F	Gold Plated
G5	Gold Plated (Thickness 5µ")
G10	Gold Plated (Thickness 10µ")
G15	Gold Plated (Thickness 15µ")
G30	Gold Plated (Thickness 30µ")

Misc Tooling, All	
Part Number	Description
CA-4020-59	Sealing Plug, Size 16 & 20

Standard Quantity Order Options	
Machined	Bulk Package, 500 Pieces
Stamped & Formed	Reel, 3000 Pieces