

REVISIONS					
REV	ECO	DESCRIPTION	DATE	BY	APPR
A1	--	RELEASED DRAWING	NOV-23-2021	BLINK	TOMMY
A2	--	UPDATED NOTE 2.6	APR-26-2023	RO	RO

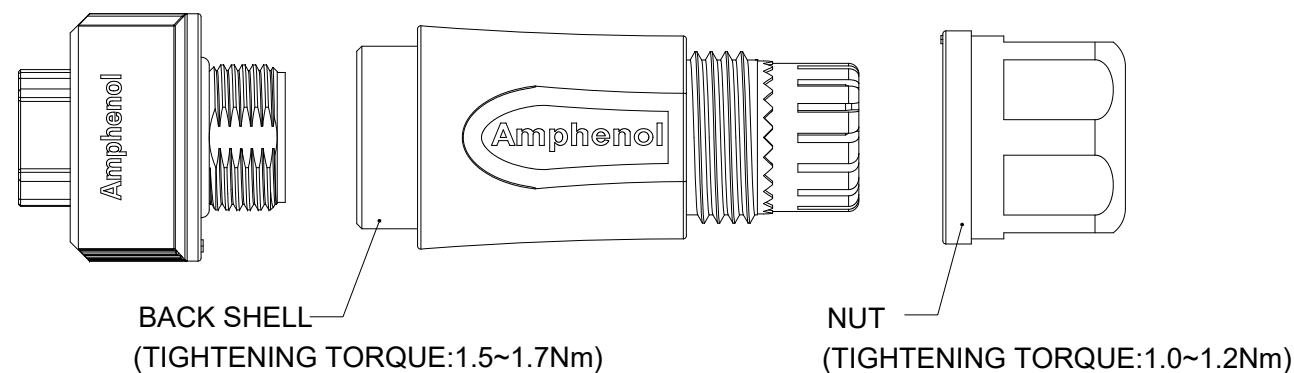
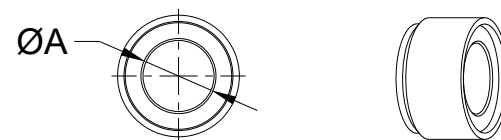
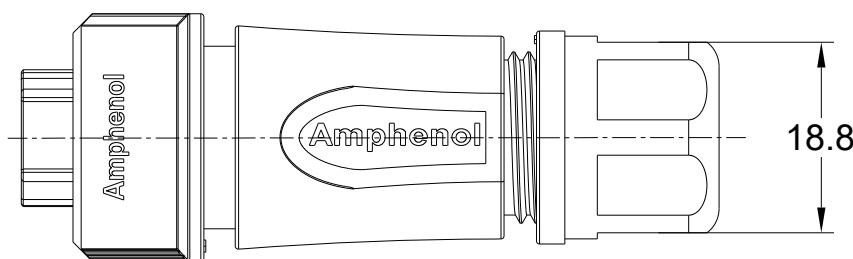
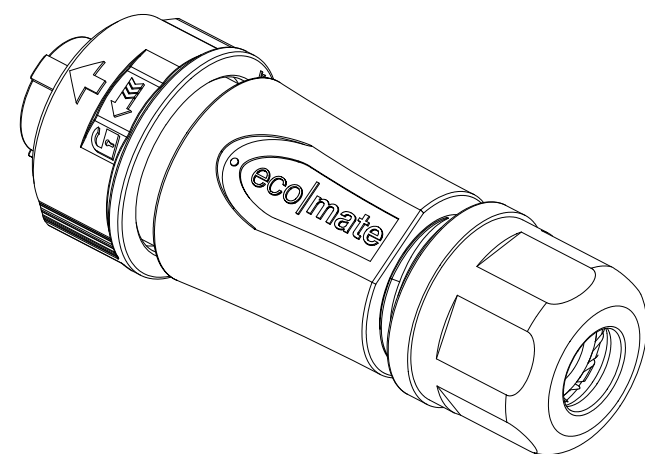
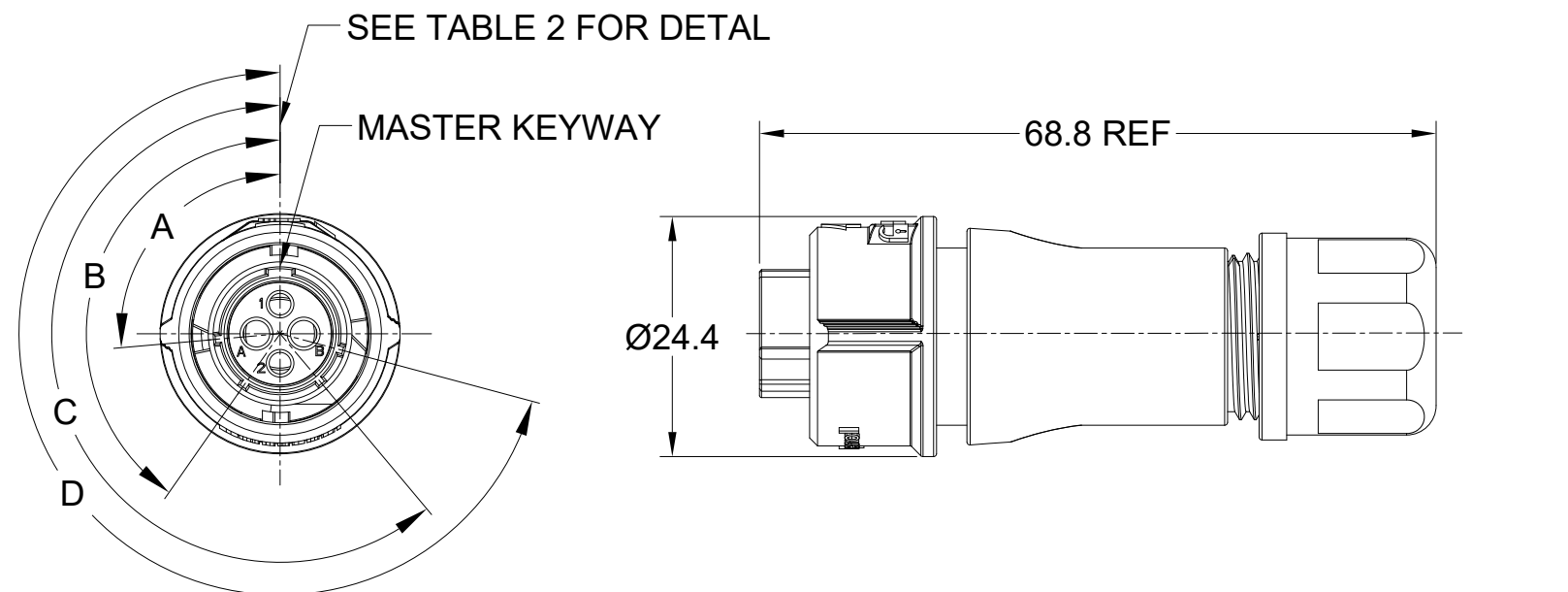

NOTES: (UNLESS OTHERWISE SPECIFIED)

- MATERIAL:
  - SHELL/COUPLING NUT: THERMOPLASTIC, BLACK, UL94 V-0.
  - INSERT: THERMOPLASTIC, BLACK, UL94 V-0.
  - SPRING: STAINLESS STEEL.
  - O-RING: SILICONE RUBBER.
  - BACK SHELL/CLAMP NUT: THERMOPLASTIC, BLACK, UL94 V-0.
  - CLAMP RING: THERMOPLASTIC, BLACK, UL94 V-0.
  - CABLE SEAL: EPDM, BLACK.
- SPECIFICATIONS:
  - 2.1 RATED CURRENT: SEE TABLE 1.
  - 2.2 RATED VOLTAGE: SEE TABLE 1.
  - 2.3 OPERATING TEMPERATURE: -40°C~125°C.
  - 2.4 DIELECTRIC WITHSTANDING VOLTAGE: SEE TABLE 1.
  - 2.5 INSULATION RESISTANCE: 5000 MEGOHMS MIN.
  - 2.6 IP--CLASS: IP67 AND IP69K IN MATED CONDITION. IP68, 1.8M (1 FATHOM) FOR A PERIOD OF 1 HOUR IN MATED CONDITION
  - 2.7 MATING CYCLES DURABILITY: 500 CYCLES MIN.
  - 2.8 RoHS COMPLIANT.
- SUITABLE CONTACTS : SEE TABLE 1.
- ALL DIMENSIONS ARE FOR REFERENCE USE ONLY.

DIMENSION ØA	CABLE OD RANGE
7.0MM	4.0-6.5mm
8.8MM	5.0-8.8mm

QUANTITY	PART NUMBER	DESCRIPTION	ITEM
<b>MATERIALS LIST</b>			
UNLESS OTHERWISE SPECIFIED 1) All dimensions are in metric(mm). 2) Tolerances are as follows: 1 PL DEC ±0.30 2 PL DEC ±0.15 3 PL DEC ±0.08 Fractions ±1/64 Angles ±1° 3) Note reference =		<b>SIGNATURES</b> <b>DATE</b> DRAWN: BLINK    NOV-23-21 CHECKED: ORION    NOV-24-21 ENGINEER: APPROVAL: TOMMY    NOV-25-21	
MATERIAL SPECIFICATIONS:		<b>Amphenol</b> Sine Systems - www.amphenol-sine.com 44724 Morley Drive Clinton Township, MI 48036	
PROCESS SPECIFICATIONS:		EcoMate Aquarius, PLUG, xx POSITION, FEMALE, SHELL SIZE 10, BACK SHELL.	
NEXT ASSY:		THIS DRAWING IS SUPPLIED FOR INFORMATION ONLY. DESIGN FEATURES, SPECIFICATIONS AND PERFORMANCE DATA SHOWN HEREON ARE THE PROPERTY OF THE AMPHENOL CORPORATION. NO RIGHTS OF REPRODUCTION ARE IMPLIED. ALL DIMENSIONS ARE SUBJECT TO NORMAL MANUFACTURING VARIATIONS.	SIZE: <b>B</b> TYPE: <b>C-</b> DWG NO.: <b>FLS6BS10xxxS03</b> REVISION: <b>A2</b>
		SCALE: NONE	SHEET 1 OF 4

TITLE: EcoMate Aquarius, PLUG, xx POSITION, FEMALE, SHELL SIZE 10, BACK SHELL.    DWG NO.: FLS6BS10xxxS03    REV: A2    SH: 1    OF: 1

REVISIONS					
REV	ECO	DESCRIPTION	DATE	BY	APPR
A1	--	RELEASED DRAWING	NOV-23-2021	BLINK	TOMMY
A2	--	UPDATED NOTE 2.6	APR-26-2023	RO	RO

TABLE 1:

PART NUMBER	FLS6BS10x3S03	FLS6BS10x4S03	FLS6BS10x2S03	FLS6BS10x3W3S03	FLS6BS10x6S03
FEMALE INSERT ARRANGEMENT FRONT VIEW					
SUITABLE CONTACTS	3 x Size 16 (1.5mm <sup>2</sup> )	4 x Size 16 (1.5mm <sup>2</sup> )	2 x Size 16 (1.5mm <sup>2</sup> ) 2 x Size 20 (0.5mm <sup>2</sup> )	3 x Size 16 (1.5mm <sup>2</sup> ) 3 x Size 20 (0.5mm <sup>2</sup> )	6 x Size 20 (0.5mm <sup>2</sup> )
RATED CURRENT	13A	13A	(16#)13A (20#)7.5A-MACHINED CONT. (20#)5A-STAMPED CONT.	(16#)13A (20#)7.5A-MACHINED CONT. (20#)5A-STAMPED CONT.	7.5A-MACHINED CONT. 5A-STAMPED CONT.
RATED VOLTAGE	500V AC/DC	500V AC/DC	500V AC/DC	500V AC/DC	250V AC/DC
DIELECTRIC WITHSTANDING VOLTAGE	2000V AC	2000V AC	2000V AC	2000V AC	1500V AC

TITLE: EcoMate Aquarius, PLUG,xx POSITION,FEMALE,SHELL SIZE 10,BACK SHELL.  
DWG NO.: FLS6BS10xxxS03  
REV: A2  
SH: 1  
OF: 1

ORDERING INFORMATION:

FLS6BS10xxxS03

PROTECTION KEY:(SEE TABLE 2):  
N KEY(STANADRD VERSION)

- W KEY
- X KEY
- Y KEY
- Z KEY

STANDS FOR INSERT ARRANGEMENT:  
2 - 4(2+2) CORES.  
3 - 3 CORES.  
4 - 4 CORES.  
3W3 - 6(3+3) CORES.  
6 - 6 CORES.

TABLE 2:

KEY POS	A	B	C	D
N	105°	140°	215°	265°
W	45°	140°	215°	265°
X	105°	160°	215°	265°
Y	105°	140°	225°	265°
Z	105°	140°	215°	295°

QUANTITY	PART NUMBER	DESCRIPTION	ITEM
<b>MATERIALS LIST</b>			
UNLESS OTHERWISE SPECIFIED		SIGNATURES      DATE	
1) All dimensions are in metric(mm).		DRAWN: BLINK	NOV-23-21
2) Tolerances are as follows:		CHECKED: ORION	NOV-24-21
1 PL DEC ±0.30		ENGINEER:	
2 PL DEC ±0.15		APPROVAL: TOMMY	NOV-25-21
3 PL DEC ±0.08		CUSTOMER:	
3) Note reference =		THIS DRAWING IS SUPPLIED FOR INFORMATION ONLY. DESIGN FEATURES, SPECIFICATIONS AND PERFORMANCE DATA SHOWN HEREON ARE THE PROPERTY OF THE AMPHENOL CORPORATION. NO RIGHTS OF REPRODUCTION ARE IMPLIED. ALL DIMENSIONS ARE SUBJECT TO NORMAL MANUFACTURING VARIATIONS.	
MATERIAL SPECIFICATIONS:		EcoMate Aquarius,PLUG,xx POSITION, FEMALE,SHELL SIZE 10,BACK SHELL.	
PROCESS SPECIFICATIONS:		SIZE: <b>B</b>	REVISION: <b>A2</b>
NEXT ASSY:		TYPE: <b>C-</b>	DWG NO.: <b>FLS6BS10xxxS03</b>
		SCALE: <b>NONE</b>	SHEET <b>2</b> OF <b>4</b>

**Amphenol**

Sine Systems - www.amphenol-sine.com  
44724 Morley Drive  
Clinton Township, MI 48036

# ecomate® RM/RSSM/Aquarius™ - Contact Size 20 Options

Machined, Crimp Contacts				
Part Number		Contact Size (AWG)	Wire Range (mm <sup>2</sup> )	Plating
Male	Female			
MP20W23F	MS20W23F	22-20AWG	0.34-0.50 mm <sup>2</sup>	Gold Flash
MP20W23G5	MS20W23G5	22-20AWG	0.34-0.50 mm <sup>2</sup>	Gold 5μ"
MP20W23G10	MS20W23G10	22-20AWG	0.34-0.50 mm <sup>2</sup>	Gold 10μ"
MP20W23G15	MS20W23G15	22-20AWG	0.34-0.50 mm <sup>2</sup>	Gold 15μ"
MP20W23G30	MS20W23G30	22-20AWG	0.34-0.50 mm <sup>2</sup>	Gold 30μ"
MP24W23F	MS24W23F	26-24AWG	0.14-0.25 mm <sup>2</sup>	Gold Flash
MP24W23G5	MS24W23G5	26-24AWG	0.14-0.25 mm <sup>2</sup>	Gold 5μ"
MP24W23G10	MS24W23G10	26-24AWG	0.14-0.25 mm <sup>2</sup>	Gold 10μ"
MP24W23G15	MS24W23G15	26-24AWG	0.14-0.25 mm <sup>2</sup>	Gold 15μ"
MP24W23G30	MS24W23G30	26-24AWG	0.14-0.25 mm <sup>2</sup>	Gold 30μ"
MP28W23F	MS28W23F	30-28AWG	0.05-0.08 mm <sup>2</sup>	Gold Flash
MP28W23G5	MS28W23G5	30-28AWG	0.05-0.08 mm <sup>2</sup>	Gold 5μ"
MP28W23G10	MS28W23G10	30-28AWG	0.05-0.08 mm <sup>2</sup>	Gold 10μ"
MP28W23G15	MS28W23G15	30-28AWG	0.05-0.08 mm <sup>2</sup>	Gold 15μ"
MP28W23G30	MS28W23G30	30-28AWG	0.05-0.08 mm <sup>2</sup>	Gold 30μ"

Stamped & Formed, Crimp Contacts				
Part Number		Contact Size (AWG)	Wire Range (mm <sup>2</sup> )	Plating
Male	Female			
SP20W2F	SS20W2F	22-20AWG	0.34-0.50 mm <sup>2</sup>	Gold Flash
SP20W2G5	SS20W2G5	22-20AWG	0.34-0.50 mm <sup>2</sup>	Gold 5μ"
SP20W2G10	SS20W2G10	22-20AWG	0.34-0.50 mm <sup>2</sup>	Gold 10μ"
SP20W2G15	SS20W2G15	22-20AWG	0.34-0.50 mm <sup>2</sup>	Gold 15μ"
SP20W2G30	SS20W2G30	22-20AWG	0.34-0.50 mm <sup>2</sup>	Gold 30μ"
SP24W2F	SS24W2F	26-24AWG	0.14-0.25 mm <sup>2</sup>	Gold Flash
SP24W2G5	SS24W2G5	26-24AWG	0.14-0.25 mm <sup>2</sup>	Gold 5μ"
SP24W2G10	SS24W2G10	26-24AWG	0.14-0.25 mm <sup>2</sup>	Gold 10μ"
SP24W2G15	SS24W2G15	26-24AWG	0.14-0.25 mm <sup>2</sup>	Gold 15μ"
SP24W2G30	SS24W2G30	26-24AWG	0.14-0.25 mm <sup>2</sup>	Gold 30μ"
SP28W2F	SS28W2F	30-28AWG	0.05-0.08 mm <sup>2</sup>	Gold Flash
SP28W2G5	SS28W2G5	30-28AWG	0.05-0.08 mm <sup>2</sup>	Gold 5μ"
SP28W2G10	SS28W2G10	30-28AWG	0.05-0.08 mm <sup>2</sup>	Gold 10μ"
SP28W2G15	SS28W2G15	30-28AWG	0.05-0.08 mm <sup>2</sup>	Gold 15μ"
SP28W2G30	SS28W2G30	30-28AWG	0.05-0.08 mm <sup>2</sup>	Gold 30μ"

Machined, Tooling	
Part Number	Description
QXRT20	Contact Extraction Tool, #20 (Ø 1.0) Contact
MFY-3959	Hand Crimp Tool for Machined Contacts
MFY-3960	Pneumatic Crimp Tool for Machined Contact

Stamped & Formed, Tooling	
Part Number	Description
QXRT20	Contact Extraction Tool, #20 (Ø 1.0) Contact
MFY-3958	Hand Tool, Stamped & Formed Contact, Size 20, 20-28AWG
MFY-3957	Crimp Die for Stamped & Formed Contact

Plating Options, All	
Symbol	Plating
T	Tin Plated (for Stamped & Formed Contacts)
S	Silver Plated 5Um (for Machined Contacts)
F	Gold Plated
G5	Gold Plated (Thickness 5μ")
G10	Gold Plated (Thickness 10μ")
G15	Gold Plated (Thickness 15μ")
G30	Gold Plated (Thickness 30μ")

Misc Tooling, All	
Part Number	Description
CA-4020-59	Sealing Plug, Size 16 & 20

Standard Quantity Order Options	
Machined	Bulk Package, 500 Pieces
Stamped & Formed	Reel, 3000 Pieces

# ecomate® RM/RSSM/Aquarius™ - Contact Size 16 Options

Machined, Crimp Contacts				
Part Number		Contact Size (AWG)	Wire Range (mm <sup>2</sup> )	Plating
Male	Female			
MP14M23F	MS14M23F	14AWG	2.0-2.5mm <sup>2</sup>	Gold Flash
MP14M23G5	MS14M23G5	14AWG	2.0-2.5mm <sup>2</sup>	Gold 5μ"
MP14M23G10	MS14M23G10	14AWG	2.0-2.5mm <sup>2</sup>	Gold 10μ"
MP14M23G15	MS14M23G15	14AWG	2.0-2.5mm <sup>2</sup>	Gold 15μ"
MP14M23G30	MS14M23G30	14AWG	2.0-2.5mm <sup>2</sup>	Gold 30μ"
MP16M23F	MS16M23F	18-16AWG	0.75-1.5mm <sup>2</sup>	Gold Flash
MP16M23G5	MS16M23G5	18-16AWG	0.75-1.5mm <sup>2</sup>	Gold 5μ"
MP16M23G10	MS16M23G10	18-16AWG	0.75-1.5mm <sup>2</sup>	Gold 10μ"
MP16M23G15	MS16M23G15	18-16AWG	0.75-1.5mm <sup>2</sup>	Gold 15μ"
MP16M23G30	MS16M23G30	18-16AWG	0.75-1.5mm <sup>2</sup>	Gold 30μ"
MP20M23F	MS20M23F	22-20AWG	0.34-0.50mm <sup>2</sup>	Gold Flash
MP20M23G5	MS20M23G5	22-20AWG	0.34-0.50mm <sup>2</sup>	Gold 5μ"
MP20M23G10	MS20M23G10	22-20AWG	0.34-0.50mm <sup>2</sup>	Gold 10μ"
MP20M23G15	MS20M23G15	22-20AWG	0.34-0.50mm <sup>2</sup>	Gold 15μ"
MP20M23G30	MS20M23G30	22-20AWG	0.34-0.50mm <sup>2</sup>	Gold 30μ"
MP24M23F	MS24M23F	26-24AWG	0.14-0.25mm <sup>2</sup>	Gold Flash
MP24M23G5	MS24M23G5	26-24AWG	0.14-0.25mm <sup>2</sup>	Gold 5μ"
MP24M23G10	MS24M23G10	26-24AWG	0.14-0.25mm <sup>2</sup>	Gold 10μ"
MP24M23G15	MS24M23G15	26-24AWG	0.14-0.25mm <sup>2</sup>	Gold 15μ"
MP24M23G30	MS24M23G30	26-24AWG	0.14-0.25mm <sup>2</sup>	Gold 30μ"

Stamped & Formed, Crimp Contacts				
Part Number		Contact Size (AWG)	Wire Range (mm <sup>2</sup> )	Plating
Male	Female			
SP14M2F	SS14M2F	14AWG	2.0-2.5mm <sup>2</sup>	Gold Flash
SP14M2G5	SS14M2G5	14AWG	2.0-2.5mm <sup>2</sup>	Gold 5μ"
SP14M2G10	SS14M2G10	14AWG	2.0-2.5mm <sup>2</sup>	Gold 10μ"
SP14M2G15	SS14M2G15	14AWG	2.0-2.5mm <sup>2</sup>	Gold 15μ"
SP14M2G30	SS14M2G30	14AWG	2.0-2.5mm <sup>2</sup>	Gold 30μ"
SP16M2F	SS16M2F	18-16AWG	0.75-1.5mm <sup>2</sup>	Gold Flash
SP16M2G5	SS16M2G5	18-16AWG	0.75-1.5mm <sup>2</sup>	Gold 5μ"
SP16M2G10	SS16M2G10	18-16AWG	0.75-1.5mm <sup>2</sup>	Gold 10μ"
SP16M2G15	SS16M2G15	18-16AWG	0.75-1.5mm <sup>2</sup>	Gold 15μ"
SP16M2G30	SS16M2G30	18-16AWG	0.75-1.5mm <sup>2</sup>	Gold 30μ"
SP20M2F	SS20M2F	22-20AWG	0.34-0.50mm <sup>2</sup>	Gold Flash
SP20M2G5	SS20M2G5	22-20AWG	0.34-0.50mm <sup>2</sup>	Gold 5μ"
SP20M2G10	SS20M2G10	22-20AWG	0.34-0.50mm <sup>2</sup>	Gold 10μ"
SP20M2G15	SS20M2G15	22-20AWG	0.34-0.50mm <sup>2</sup>	Gold 15μ"
SP20M2G30	SS20M2G30	22-20AWG	0.34-0.50mm <sup>2</sup>	Gold 30μ"
SP24M2F	SS24M2F	26-24AWG	0.14-0.25mm <sup>2</sup>	Gold Flash
SP24M2G5	SS24M2G5	26-24AWG	0.14-0.25mm <sup>2</sup>	Gold 5μ"
SP24M2G10	SS24M2G10	26-24AWG	0.14-0.25mm <sup>2</sup>	Gold 10μ"
SP24M2G15	SS24M2G15	26-24AWG	0.14-0.25mm <sup>2</sup>	Gold 15μ"
SP24M2G30	SS24M2G30	26-24AWG	0.14-0.25mm <sup>2</sup>	Gold 30μ"

Machined, Tooling	
Part Number	Description
QXRT16	Contact Extraction Tool, #16 (Ø 1.6) Contact
MFX-3959	Hand Crimp Tool for Machined Contacts
MFX-3960	Pneumatic Crimp Tool for Machined Contact

Stamped & Formed, Tooling	
Part Number	Description
QXRT16	Contact Extraction Tool, #16 (Ø 1.6) Contact
MFX-3954	Hand Tool, Stamped & Formed Contact, Size 16, 20-14AWG
MFX-3957	Crimp Die, Stamped & Formed Contact

Plating Options, All	
Symbol	Plating
T	Tin Plated (for Stamped & Formed Contacts)
S	Silver Plated 5Um (for Machined Contacts)
F	Gold Plated
G5	Gold Plated (Thickness 5μ")
G10	Gold Plated (Thickness 10μ")
G15	Gold Plated (Thickness 15μ")
G30	Gold Plated (Thickness 30μ")

Misc Tooling, All	
Part Number	Description
CA-4020-59	Sealing Plug, Size 16 & 20

Standard Quantity Order Options	
Machined	Bulk Package, 500 Pieces
Stamped & Formed	Reel, 3000 Pieces