

Demonstration System EPC9153 Quick Start Guide

*44–60 V Input, 12-20 V, 12.5 A Output
up to 250 W High Efficiency, Thin Power Module*

Revision 1.0



DESCRIPTION

The EPC9153 demonstration board is a synchronous buck converter with 60 V maximum input voltage, 12.5 A maximum output current, and 12-20 V (default set to 20 V) regulated output voltage. The simplified schematic diagram is shown in Figure 1. It features the 100 V EPC2218 and EPC2038 GaN FETs. Other features include:

- High efficiency: 98.2% @ 20 V/12.5 A output
- Low profile: 6.5 mm component height
- Temperature rise: < 40 °C @ 20 V with 12.5 A output
- Constant switching frequency: 400 kHz
- Re-programmable
- 150% over current for 10 ms
- 200% over current for 1 ms
- Fault protection:
 - Input undervoltage
 - Input overvoltage
 - Output over voltage
 - Short circuit
 - Over current

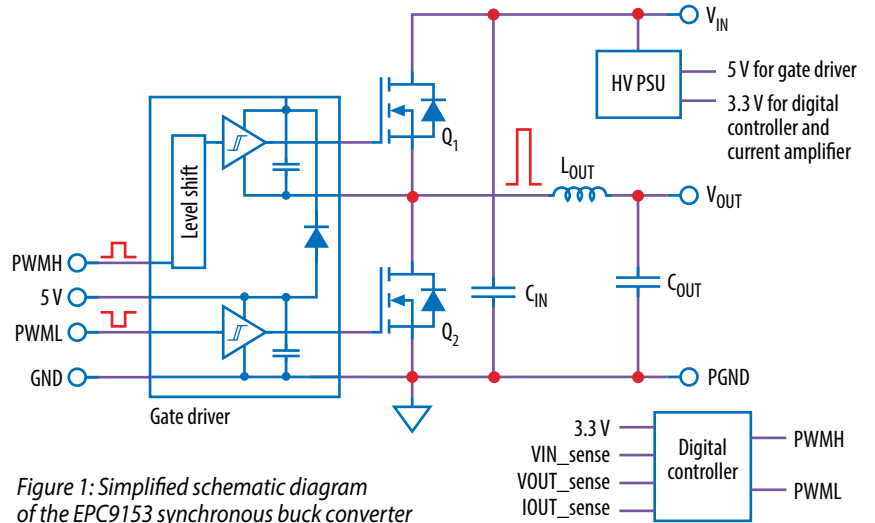

Figure 1: Simplified schematic diagram of the EPC9153 synchronous buck converter

REGULATORY INFORMATION

This converter is for evaluation purposes only. It is not a full-featured converter and cannot be used in final products. No EMI test was conducted. It is not FCC approved.

FIRMWARE UPDATES

Every effort has been made to ensure all control features function as specified. It may be necessary to provide updates to the firmware. Please check the EPC and Microchip websites for the latest firmware updates.

Table 1: Absolute Maximum Ratings

Symbol	Parameter	Conditions	Min	Max	Units
V _{IN}	Input voltage			80	V

Table 2: Electrical Characteristics (T_A = 25°C unless specified otherwise)

Symbol	Parameter	Conditions	Min	Typ	Max	Units	
V _{IN}	Input Voltage		44	56	60	V	
V _{IN,on}	Input UVLO Turn on Voltage		42	44			
V _{IN,off}	Input UVLO Turn off Voltage		40	42			
V _{IN_OVP}	Input Over Voltage Protection		59.5	60			
V _{OUT}	Output Voltage			20		V	
t _{OUT,rise}	Output Voltage Rise Time	V _{IN} = 56 V, I _{OUT} = 0 A		6			ms
ΔV _{OUT}	Output Voltage Ripple	I _{OUT} = 12.5 A		40			mV
V _{OUT_OVP}	Output Over Voltage Protection		21.7	25.5			
V _{OUT_150%}	Output Voltage at 150% Transient Overcurrent	I _{OUT} = 18.75 A, over current period = 10 ms	18.5				
V _{OUT_200%}	Output Voltage at 200% Transient Overcurrent	I _{OUT} = 25 A, over current period = 1 ms	18.5				
V _{OUT_OS}	Output Voltage Overshoot at Load Step	Load step = 11.25 A to 0 A, V _{IN} = 56 V			21.5		
V _{OUT_US}	Output Voltage Undershoot at Load Step	Load step = 0 A to 11.25 A, V _{IN} = 56 V	18.5				
I _{OUT}	Output Current		0		12.5		A
I _{OUT,limit}	Overcurrent Limit Threshold		14	17			
f _s	Switching Frequency			400		kHz	
T _{rise}	Temperature Rise	V _{IN} = 56 V, I _{OUT} = 12.5 A, heat-spreader installed, no forced air, measured at heat-spreader	33		38	°C	



EPC9153 board - Variant 1, Wurth inductor

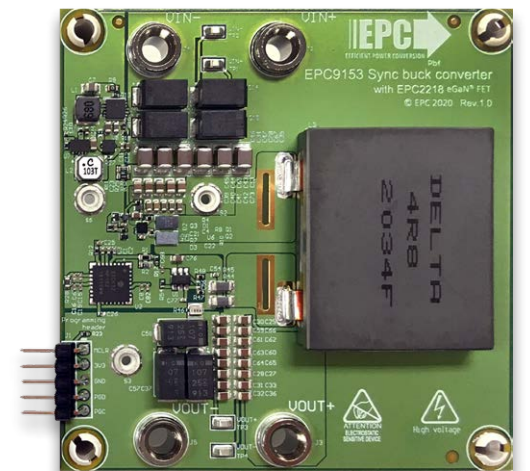

EPC9153 board - Variant 2, Delta/Cyntec inductor

ELECTRICAL PERFORMANCE

Typical efficiency and power loss

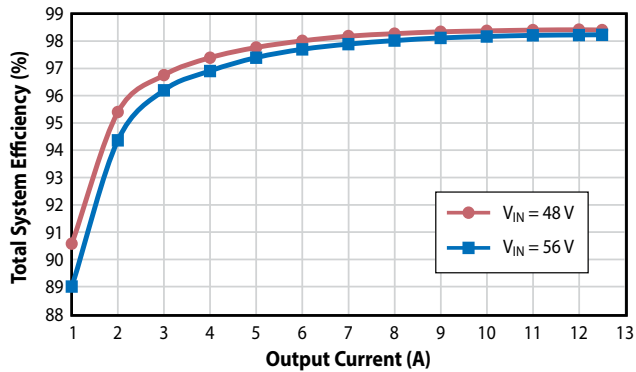

Figure 2: 20 V output, different input voltages

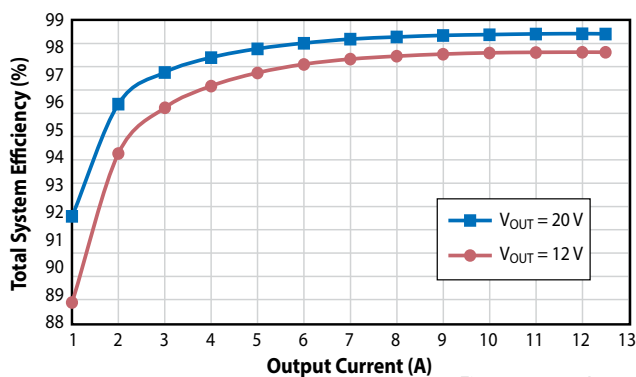
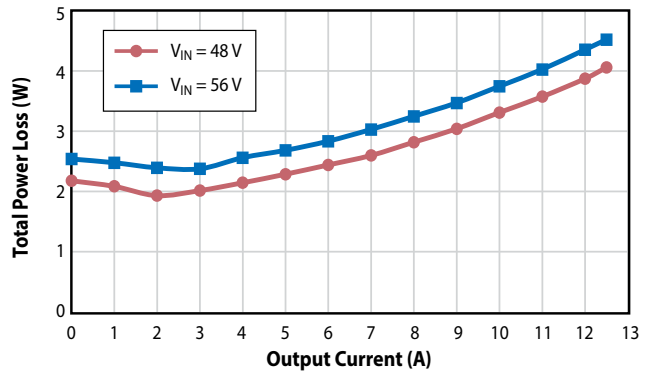
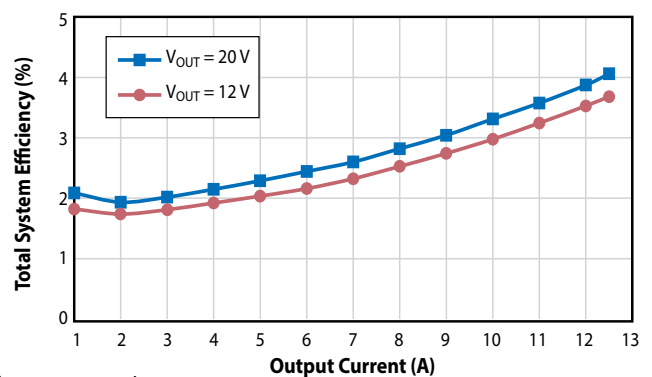

Figure 3: 12.5 A output, different output voltages



Typical output voltage ripple

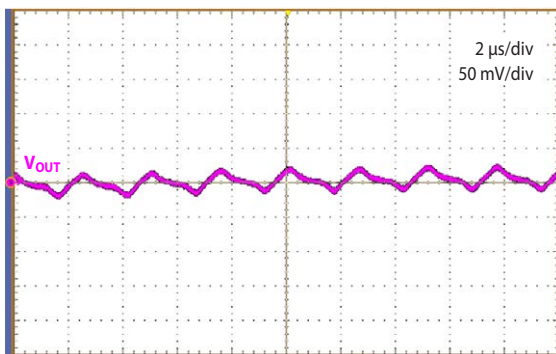

Figure 4: $V_{IN} = 56V, V_{OUT} = 20V, I_{OUT} = 12.5A$

Typical transient response

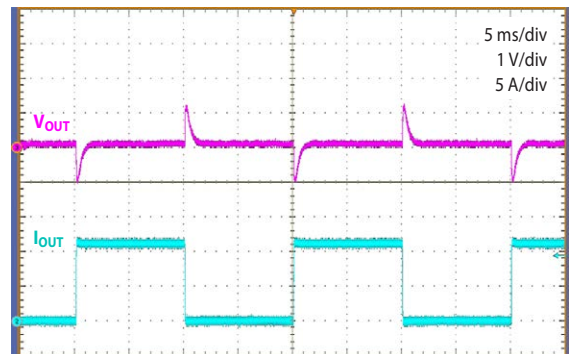

Figure 5: $V_{IN} = 56V, V_{OUT} = 20V, 10\% (1.25A) \text{ to } 100\% (12.5A)$

Startup

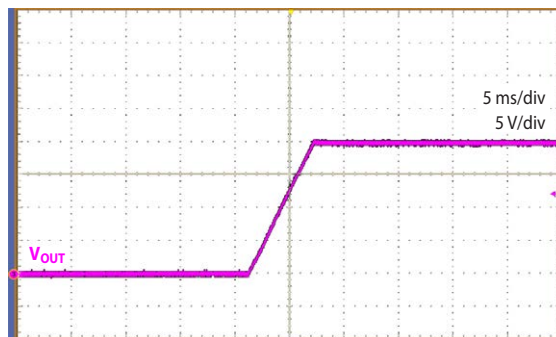

Figure 6: Start-up at $V_{IN} = 56V, V_{OUT} = 20V, I_{OUT} = 12.5A$

Typical switching waveform



Figure 7: Measured switch-node voltage at $V_{IN} = 56V, V_{OUT} = 20V, I_{OUT} = 12.5A$

ELECTRICAL PERFORMANCE *(continued)*

Overcurrent protection

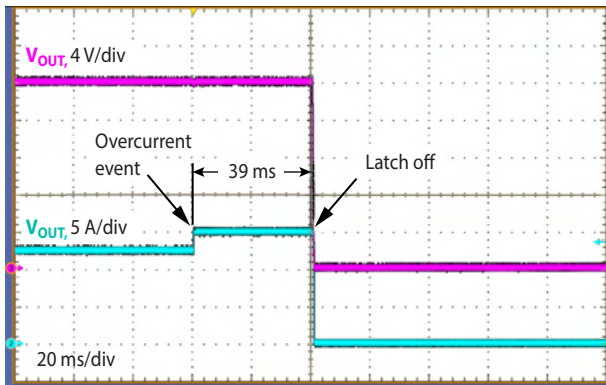

Figure 8: Output voltage and current waveforms at overcurrent protection

OPERATING CONSIDERATIONS

Controller

The EPC9153 synchronous buck power module features a Microchip Technology dsPIC33CK32MP102 Digital Signal Controller DSC. This 100 MHz single core device is equipped with dedicated peripheral modules for Switched-Mode Power Supply (SMPS) applications, such as a feature-rich 4-channel (8x output), 250 ps resolution pulse width modulation (PWM) logic, three 3.5 Msps Analog-To-Digital Converters (ADC), three 15 ns propagation delay analog comparators with integrated Digital-To-Analog Converters (DAC) supporting ramp signal generation, three operational amplifiers as well as Digital Signal Processing (DSP) core with tightly coupled data paths for high performance real-time control applications. The device used is the smallest derivative of the dsPIC33CK single core and dsPIC33CH dual core DSC families. The device used in this design comes in a 28 pin 6x6 mm UQFN package, specified for ambient temperatures from -40 to +125° C. Other packages including a 28 pin UQFN package with only 4x4 mm are available.

The dsPIC33CK device is used to drive and control the converter in a fully digital fashion where the feedback loops are implemented and executed in software. Migrating control loop execution from analog circuits to embedded software enhances the flexibility in terms of

applied control laws as well as making modifications to the feedback loop and control signals during runtime, optimizing control schemes and adapting control accuracy and performance to most recent operating conditions. As a result, digital control allows users to tailor the behavior of the converter to application specific requirements without the need for modifying hardware.

Programming

The Microchip dsPIC33CK controller can be re-programmed using the in-circuit serial programming port (ICSP) available on the 5-pin header. This interface supports the Microchip in-circuit programmers/debuggers, such as MPLAB® ICD4, MPLAB® REAL ICE or MPLAB® PICkit4 and previous derivatives.

Control loop

The EPC9153 synchronous buck converter module adopts constant frequency, average current mode control implemented by a Microchip dsPIC33CK32MP102 Digital Signal Controller (DSC). The error between the output voltage feedback signal and the voltage reference is fed to an error amplifier and generate a current reference signal. Another error amplifier compares the sensed inductor average current with this current reference, and generates a command signal that drives the pulse width modulator. When the output current increases, the decrease in the voltage feedback signal causes the command signal to increase until the average inductor current matches the new output current.

Soft start-up

The start-up of the EPC9153 output voltage is programmed to be a soft start-up: Once the input voltage passes the input UVLO threshold, the output voltage rises monotonously from 0 to its final value without overshoot in 6 ms. The rise time can be changed through a re-program of the controller.

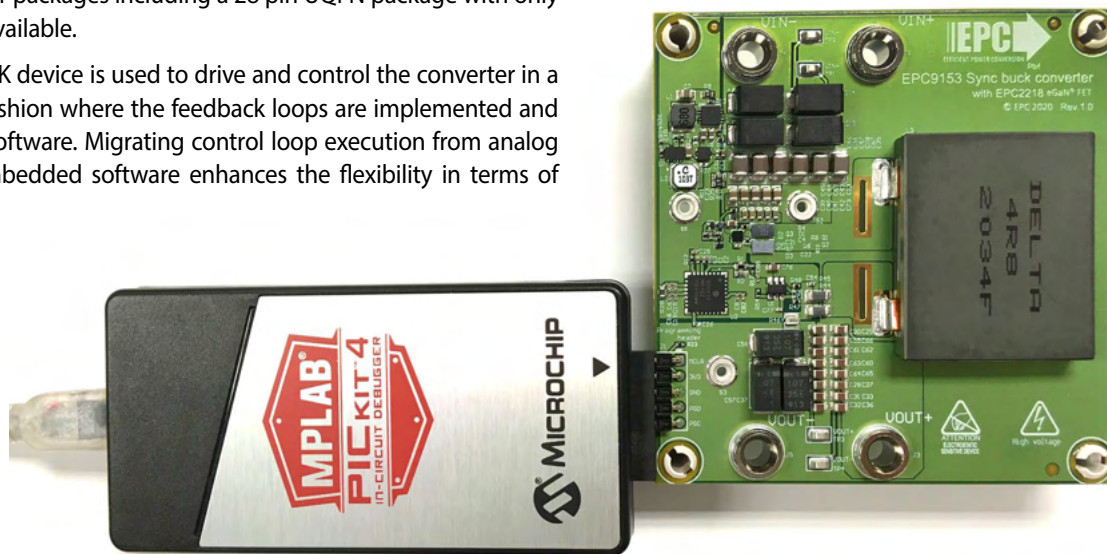

Figure 9: Programming connection

FAULT PROTECTION

Several basic fault handlers have been implemented. Whenever a fault condition is tripped, the PWM signals are switched off and the converter shuts down. And it will remain in this shut-down state. To restart, the input voltage needs to be removed, and then reapplied. Once the output voltage drops below 2.5 V, the converter will attempt to restart.

Over-Current Protection

The maximum rated continuous output current is 12.5 A. It can also handle 150% over current (12.5 A to 18.75 A) for 10 ms, and 200% over current (12.5 A to 25 A) for 1 ms. When the total duration of the over current event exceeds the time limit, the over-current fault will trip.

In addition, if the output current is higher than 15 A for longer than 30 ms, the over-current fault will trip as well.

Short-Circuit Protection

The short-circuit fault will trip when the output is shorted to ground. If the short is present before powering up, the converter will not start.

Output Over-Voltage Protection

If the output voltage is 3.5 V above the set point, the PWM signals are switched off.

THERMAL MANAGEMENT

Thermal management is very important to ensure proper and reliable operation. The EPC9153 is intended for bench evaluation at normal ambient temperature. The addition of a heat-spreader or heatsink and forced air cooling can significantly increase the current rating of the power devices, but care must be taken to not exceed the absolute maximum die temperature of 150°C.

The EPC9153 board is designed with three mechanical spacers that accept M2 x 0.4 mm thread screws and can be used to easily attach a heat-spreader/heatsink as shown in Figure 10. It only requires a thermal interface material (TIM), a custom shape heat-spreader/heatsink, a thin insulation layer for the components with exposed conductors such as capacitors and resistors and screws. The EPC9153 with the heat-spreader installed is shown in Figure 11.

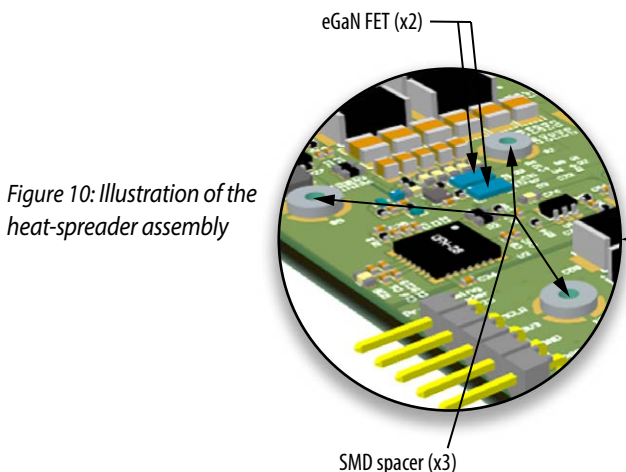

Figure 10: Illustration of the heat-spreader assembly

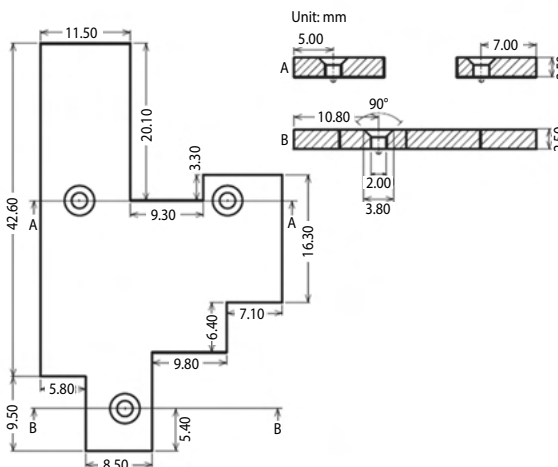
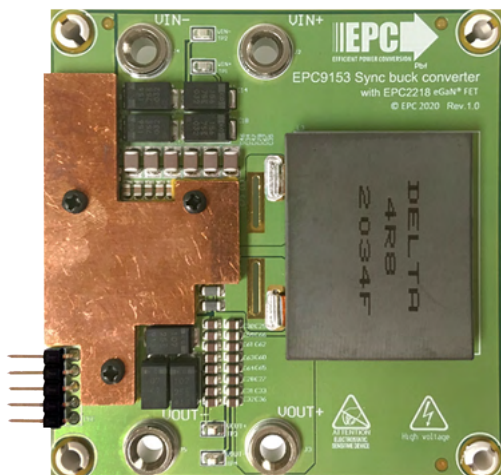
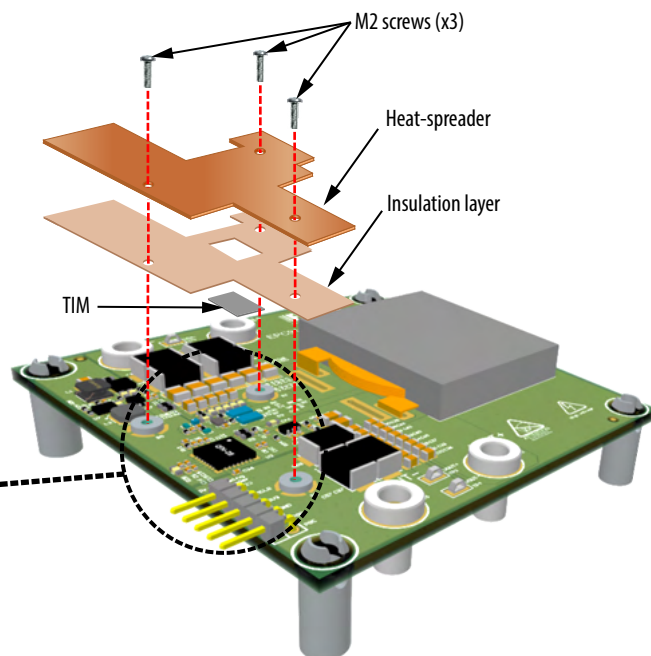

Figure 11: (left) EPC9153 with heat-spreader assembled (right) Dimensions of the heat-spreader

THERMAL MANAGEMENT (continued)

The choice of TIM needs to consider the following characteristics:

- **Mechanical compliance** – The TIM becomes compressed during heatsink attached and exerts a force on the FETs. A maximum compression of 2:1 is recommended for maximum thermal performance and to constrain the mechanical force that maximizes thermal mechanical reliability.
- **Electrical insulation** – The backside of the eGaN FETs are substrate that are connected to source and the upper FET will thus be connected to the switch-node. The TIM must therefore provide insulation to prevent short-circuiting the upper FET to the ground.
- **Thermal performance** – The choice of thermal material will affect the thermal performance. Higher thermal conductivity materials will result in higher thermal performance.

EPC recommends t-Global P/N: TG-X 500 μm for the thermal interface material.

As shown in Figure 12, the EPC9153 board with the heat-spreader installed measures a temperature rise of less than 40 °C at full load operation without any forced air.

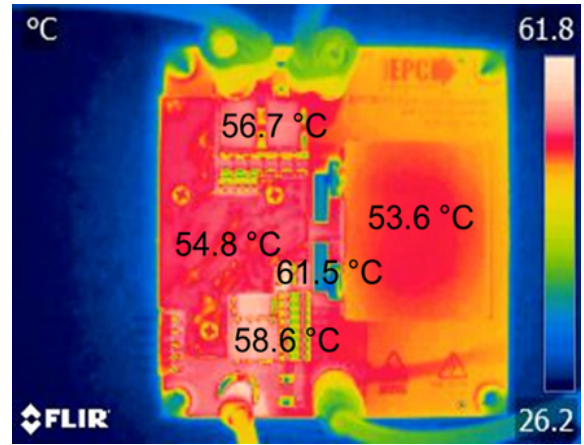

Figure 12: Thermal image of the EPC9153 operating at 56 V_{IN} , 20 V and 12.5 A output, thermal steady state

Thermal derating

Without sufficient thermal management, the output current capability is reduced. If the user decides to uninstall the heatsink, the module temperature should be monitored to ensure the maximum temperature does not exceed the rating.

QUICK START OPERATING PROCEDURE

The EPC9153 synchronous buck converter module is easy to set up for evaluation. Refer to Figures 13-14 and follow the procedure below for proper connection and measurement setup:

1. With power off, connect the input power supply to VIN+ and VIN- as shown in Figure 13.
2. With power off, connect the load to VOUT+ and VOUT- as in Figure 12.

3. Making sure the initial input supply voltage is 0 V, turn on the power and increase the voltage to the required value (do not exceed the absolute maximum voltage 60 V). Output voltage regulation begins at 44 V input voltage.
4. Once operational, adjust the load within the operating range and observe the switching behavior, efficiency, transient response and other parameters as in Figure 14.
5. For shutdown, please follow the above steps in reverse.

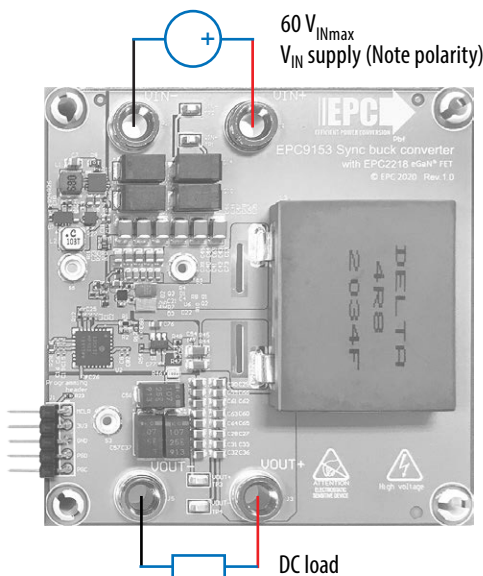

Figure 13: Input and output connection

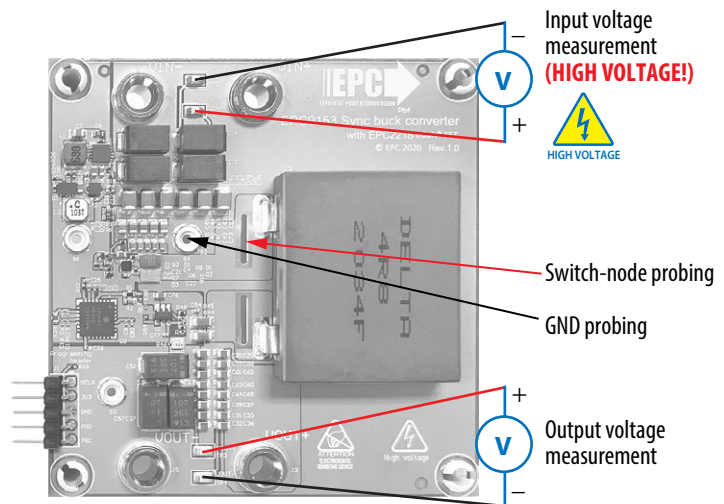

Figure 14: Measurement connection

MECHANICAL SPECIFICATIONS

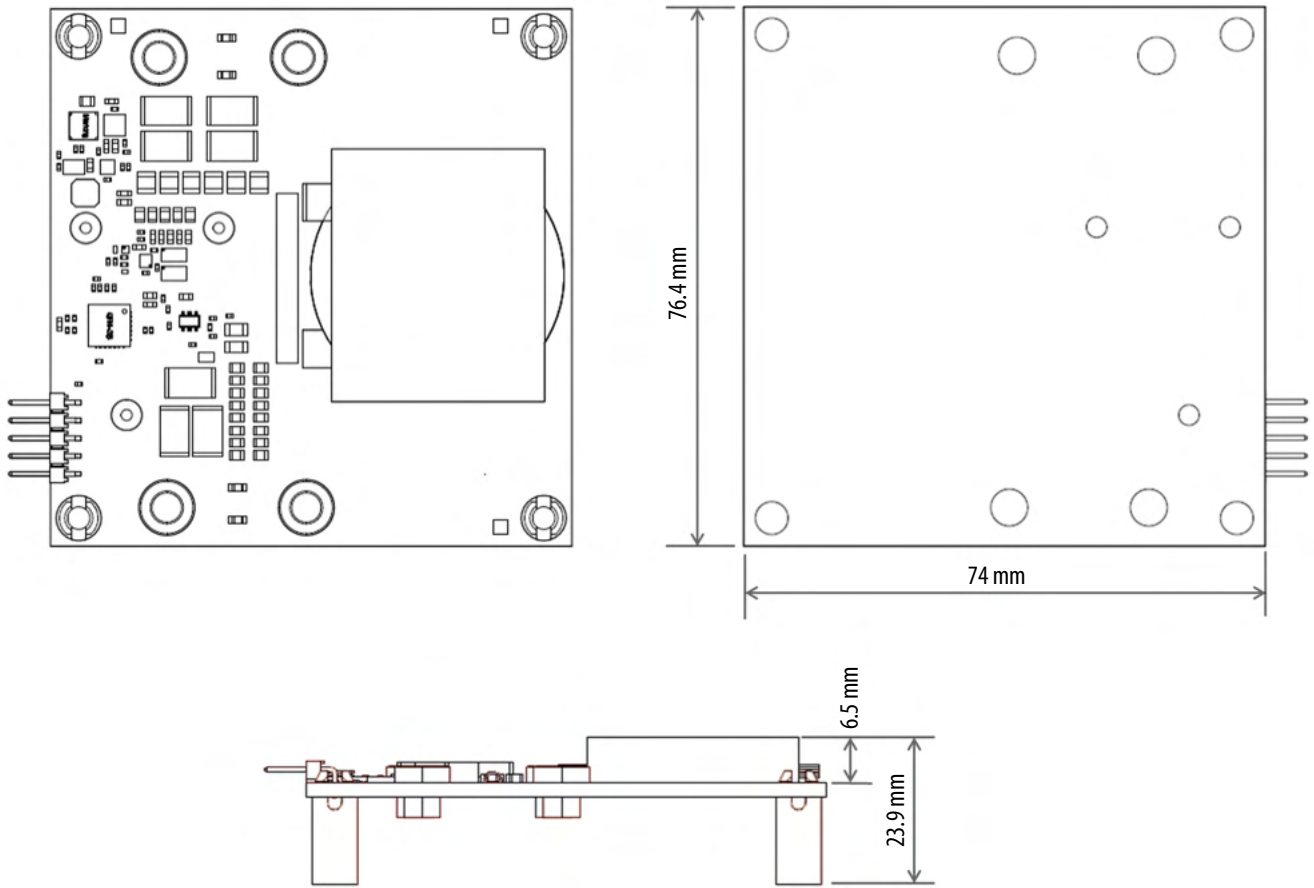

Figure 15: EPC9153 mechanical dimensions

Table 3: Bill of Materials

Item	Qty	Reference	Part Description	Manufacturer	Part #
1	4	C14, C17, C18, C20	15 μ F Tantalum Polymer Capacitor 75 V	Kemet	T521X156M075ATE035
2	3	C37, C57, C58	100 μ F Tantalum Polymer Capacitor 25 V	Kemet	T521X107M025ATE03
3	6	C34, C35, C46, C47, C67, C78	10 μ F \pm 10% 75 V Ceramic Capacitor X7R 1210	TDK	C3225X7R1N106K250AC
4	6	C7, C13, C43, C44, C45, C69	1 μ F \pm 10% 100 V Ceramic Capacitor X7R 0805	AVX	08051C105K4Z2A
5	16	C27, C28, C29, C30, C31, C32, C33, C36, C59, C60, C61, C62, C63, C64, C65, C66	4.7 μ F \pm 10% 50 V Ceramic Capacitor X7R 0805	TDK	C2012X7R1H475K125AC
6	1	C4	1 μ F \pm 10% 35 V Ceramic Capacitor X7R 0603	TDK	C1608X7R1V105K080AC
7	1	C9	1 μ F \pm 10% 25 V Ceramic Capacitor X7R 0603	Wurth	885012206076
8	1	C10	10 μ F \pm 20% 6.3 V Ceramic Capacitor X7R 0603	Samsung	CL10B106MQ8NRNC
9	5	C39, C40, C41, C42, C73	0.1 μ F \pm 10% 100 V Ceramic Capacitor X7R 0603	Murata	GRM188R72A104KA35D
10	1	C24	22 μ F \pm 20% 16 V Ceramic Capacitor X5R 0603	Samsung	CL10A226M07JZNC
11	1	C76	2.2 μ F \pm 20% 16 V Ceramic Capacitor X7R 0603	Taiyo Yuden	EMK107BB7225MA-T
12	1	C1	680 pF \pm 5% 25 V Ceramic Capacitor C0G, NP0 0402	Murata	GRM1555C1E681JA01D
13	1	C2	51 pF \pm 5% 50 V Ceramic Capacitor C0G, NP0 0402	Samsung	CL05C510JB5NNNC
14	1	C3	10 nF \pm 20% 100 V Ceramic Capacitor X7S 0402	TDK	C1005X7S2A103M050BB
15	1	C5	22 nF \pm 10% 25 V Ceramic Capacitor X7R 0402	TDK	C1005X7R1E223K050BB
16	2	C6, C82	10 nF \pm 10% 16 V Ceramic Capacitor X7R 0402	Kemet	C0402C103K4RECAUTO
17	6	C8, C15, C16, C19, C21, C68	0.1 μ F \pm 10% 25 V Ceramic Capacitor X7R 0402	Yageo	CC0402KRX7R8BB104
18	2	C11, C22	0.47 μ F \pm 10% 10 V Ceramic Capacitor X7R 0402	Taiyo Yuden	LMK105B7474KV-F
19	1	C12	10 μ F \pm 20% 10 V Ceramic Capacitor X5R 0402	Samsung	CL05A106MP5NUNC
20	1	C23	2.2 μ F \pm 20% 25 V Ceramic Capacitor X5R 0402	TDK	C1005X5R1E225M050BC
21	1	C25	220 pF \pm 10% 50 V Ceramic Capacitor X7R 0402	Kemet	C0402C221K5RACTU
22	1	C54	33 pF \pm 5% 50 V Ceramic Capacitor C0G, NP0 0402	Samsung	CL05C330JB5NNNC
23	1	C77	10 nF \pm 10% 50 V Ceramic Capacitor X7R 0402	Kemet	C0402C103K5REC7411
24	1	D1	Zener Diode 5.1 V, 250 mW \pm 6%	Diodes	BZT52C5V1LP-7
25	2	D2, D3	Diode Schottky 40 V, 200 mA	Diodes	BAS40LP
26	1	J1	Connector Header, Right Angle 5 position 0.1"	Wurth	61300511021
27	4	J2, J3, J4, J5	Banana Jack Connector	Keystone	575-4
28	1	L1	68 μ H Inductor 540 mA, 840 m Ω	Wurth	74404042680
29	1	L2	2.2 μ H Inductor 20% 2.5 A, 100 m Ω	Coilcraft	LPS4012
30	1	L3	4.8 μ H Inductor 15 A, 1 m Ω	Cyntec Wurth	4R8 2034F 7443764965048
31	2	Q1, Q2	100 V GaN FET, 3.2 m Ω	EPC	EPC2218
32	1	Q3	100 V GaN FET, 2.8 Ω	EPC	EPC2038
33	1	R1	31.6 k Ω \pm 0.1% 0.1 W Chip Resistor 0603	Panasonic	ERA-3AEB3162V
34	1	R2	2.7 k Ω \pm 0.1% 0.1 W Chip Resistor 0603	Panasonic	ERA-3AEB272V
35	1	R3	180 k Ω \pm 0.1% 0.1 W Chip Resistor 0603	Panasonic	ERA-3AEB184V
36	1	R6	9.1 k Ω \pm 0.1% 0.2 W Chip Resistor 0603	Panasonic	ERJ-PB3B9101V
37	1	R9	0 Ω Jumper 0.1 W Chip Resistor 0603	Panasonic	ERJ-3GEY0R00V
38	1	R11	0 Ω Jumper 0.063 W Chip Resistor 0402	Yageo	RC0402JR-070RL
39	3	R4, 48, R10	1 Ω \pm 1% 0.063 W Chip Resistor 0402	Yageo	RC0402FR-071RL
40	1	R5	27 k Ω \pm 5% 0.1 W Chip Resistor 0402	Panasonic	ERJ-2GEJ273X
41	1	R7	4.7 Ω \pm 1% 0.063 W Chip Resistor 0402	Stackpole	RMCF0402FT4R70
42	2	R12, R23	10 k Ω \pm 5% 0.063 W Chip Resistor 0402	Yageo	RC0402JR-0710KL
43	1	R13	1 k Ω \pm 5% 0.063 W Chip Resistor 0402	Yageo	RC0402JR-071KL
44	1	R16	100 k Ω \pm 1% 0.063 W Chip Resistor 0402	Yageo	RT0402FRE07100KL
45	2	R17, R54	20 Ω \pm 0.5% 0.063 W Chip Resistor 0402	Yageo	RT0402DRE0720RL
46	2	R18, R26	31.6 k Ω \pm 1% 0.063 W Chip Resistor 0402	Yageo	RC0402FR-0731K6L

Table 4: Bill of Materials (continued)

Item	Qty	Reference	Part Description	Manufacturer	Part #
47	1	R24	90.9 k Ω \pm 0.1% 0.063 W Chip Resistor 0402	Panasonic	ERA-2AEB9092X
48	1	R28	180 Ω @ 100 MHz Ferrite Bead 0603	Murata	BLM18PG181SN1D
49	2	R44, R45	50 Ω @ 100 MHz Ferrite Bead 1206	Murata	BLM31SN500SH1L
50	1	R46	1 m Ω \pm 5% 1 W Chip Resistor Wide 0805	Susumu	KRL2012E-M-R001-J-T5
51	2	R47, R48	0 Ω Jumper 0.1 W Chip Resistor 0402	Panasonic	ERJ-2GE0R00X
52	3	S2, S3, S5	Round Standoff Threaded M2x0.4 Steel 0.039"	Würth	9774010243R
53	4	SO1, SO2, SO3, SO4	Board Support Snap Fit / Snap Fit Nylon 0.625"	Keystone	8834
54	4	TP1, TP2, TP3, TP4	PC Test Point	Keystone	5015
55	1	U1	Current Sense Amplifier SOT-23-6	Microchip	MCP6C02T-050E/CHY
56	1	U2	dsPIC dsPIC™ 33CK Microcontroller IC 16-Bit 100 MHz 32 KB	Microchip	DSPIC33CK32MP102-I/2N
57	1	U4	Buck Switching Regulator IC Adjustable Output 150 mA 10-VDFN	TI	LM5165DRCR
58	1	U5	Linear Voltage Regulator IC 500mA 6-WSON	TI	TLV75533PDRVR
59	1	U6	UPI, UP1966A, USMD, BGA	UPI	uP1966AFBB
60	1	U7	Buck, Buck-Boost Switching Regulator IC 500 mA 10-WDFN	TI	TPS62175DQCR
61	3	SC1, SC2, SC3	M2 x 0.4 mm Threaded Screw, 5 mm	McMaster-Carr	91698A201
62	1	TIM1	Thermal pad	t-Global	TG-X x y 0.5
63	1	TIM2	Thermal pad	Laird	A14692-30
64	1	HS1	Custom heat-spreader		See Figure 11
65	2	R25, R27	0 Ω Jumper 0.063 W Chip Resistor 0402	Yageo	RC0402JR-070RL
66	1	C26	51 pF \pm 5% 50 V Ceramic Capacitor NPO 0402	Samsung	CL05C510JB5NNNC
67	1	C56	33 pF \pm 5% 50 V Ceramic Capacitor NPO 0402	Samsung	CL05C330JB5NNNC

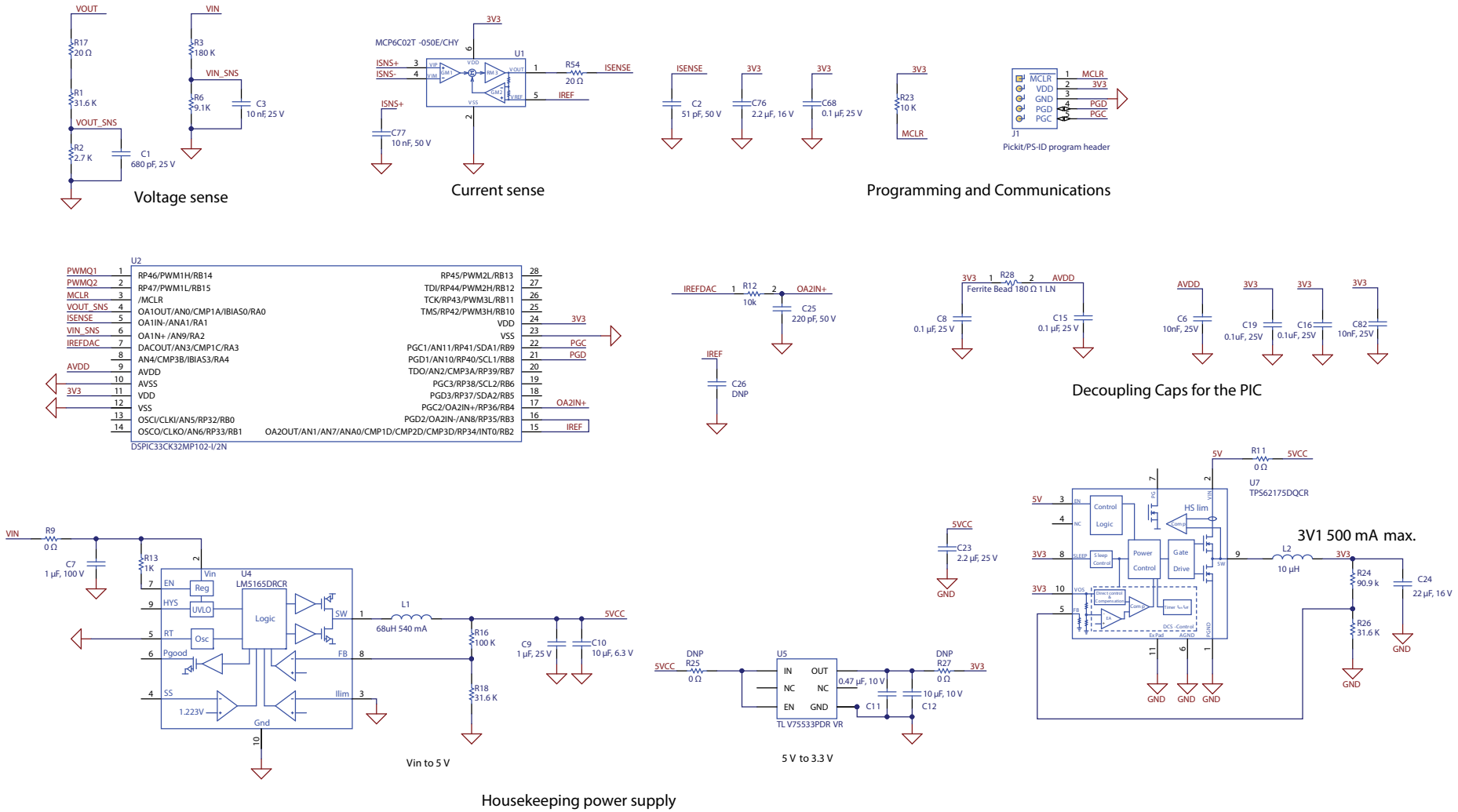
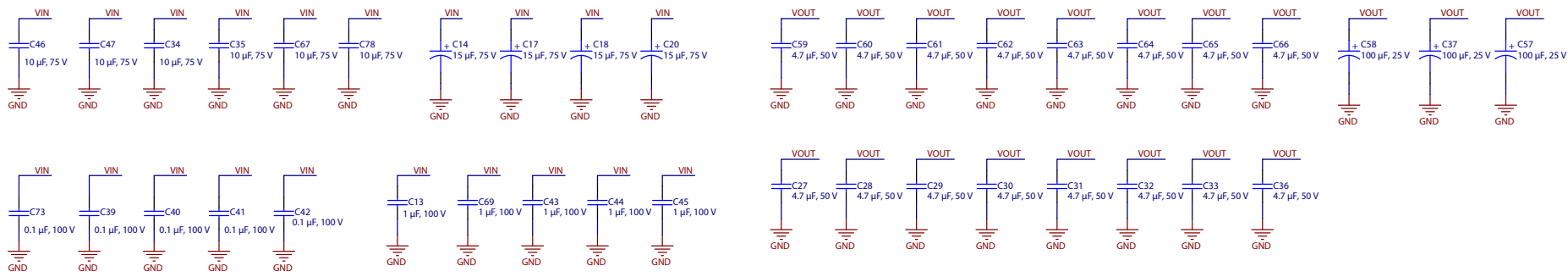
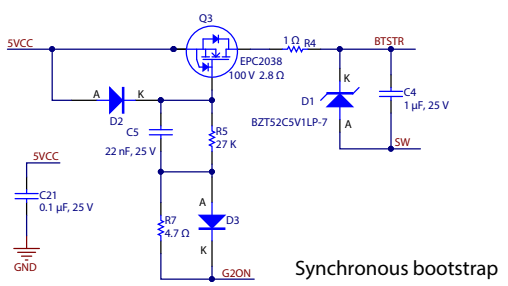

Figure 16: EPC9153 Controller schematic



Input capacitors

Output capacitors



Synchronous bootstrap

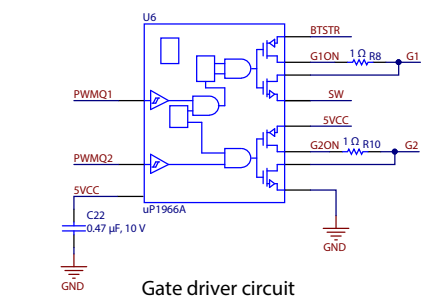

Gate driver circuit

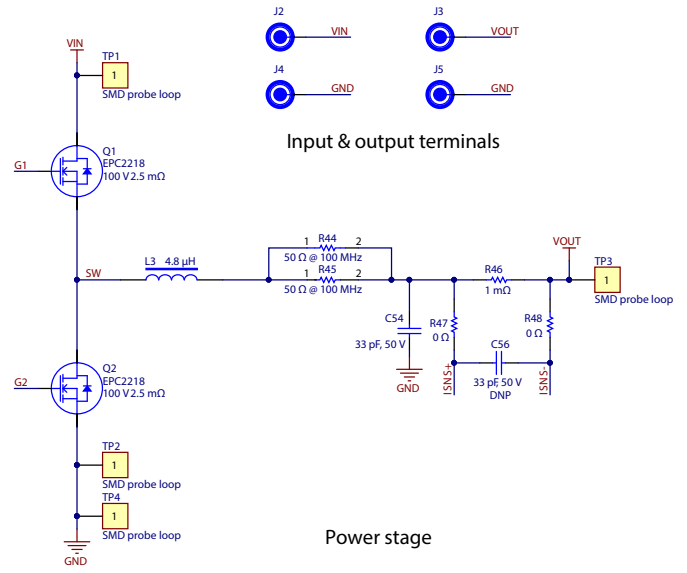

Power stage

Input & output terminals

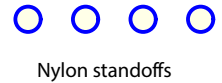

Nylon standoffs

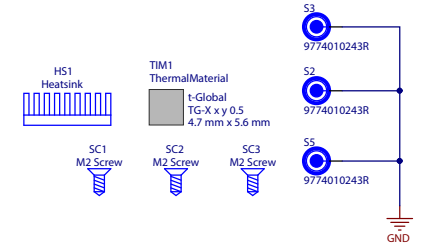

Heatspreader kit



Figure 17: EPC9153 Power Stage schematic



EPC would like to acknowledge Microchip Technology Inc. (www.microchip.com) for their support of this project.

Microchip Technology Incorporated is a leading provider of smart, connected and secure embedded control solutions. Its easy-to-use development tools and comprehensive product portfolio enable customers to create optimal designs, which reduce risk while lowering total system cost and time to market. The company's solutions serve customers across the industrial, automotive, consumer, aerospace and defense, communications and computing markets.

The EPC9153 system features the [dsPIC33CK32MP102](#) 16-Bit Digital Signal Controller with High-Speed ADC, Op Amps, Comparators and High-Resolution PWM. Learn more at www.microchip.com.

For More Information:

Please contact info@epc-co.com
or your local sales representative

Visit our website:
www.epc-co.com

Sign-up to receive
EPC updates at
bit.ly/EPCupdates
or text "EPC" to 22828

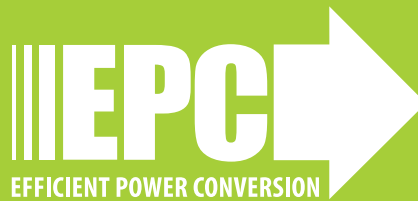

EPC Products are distributed through Digi-Key.
www.digikey.com

Demonstration Board Notification

The EPC9153 board is intended for product evaluation purposes only. It is not intended for commercial use nor is it FCC approved for resale. Replace components on the Evaluation Board only with those parts shown on the parts list (or Bill of Materials) in the Quick Start Guide. Contact an authorized EPC representative with any questions. This board is intended to be used by certified professionals, in a lab environment, following proper safety procedures. Use at your own risk.

As an evaluation tool, this board is not designed for compliance with the European Union directive on electromagnetic compatibility or any other such directives or regulations. As board builds are at times subject to product availability, it is possible that boards may contain components or assembly materials that are not RoHS compliant. Efficient Power Conversion Corporation (EPC) makes no guarantee that the purchased board is 100% RoHS compliant.

The Evaluation board (or kit) is for demonstration purposes only and neither the Board nor this Quick Start Guide constitute a sales contract or create any kind of warranty, whether express or implied, as to the applications or products involved.

Disclaimer: EPC reserves the right at any time, without notice, to make changes to any products described herein to improve reliability, function, or design. EPC does not assume any liability arising out of the application or use of any product or circuit described herein; neither does it convey any license under its patent rights, or other intellectual property whatsoever, nor the rights of others.