



Enterprise PCIe U.2 SSD Specification

(EMP I PRO Series, 3D NAND)

Version 1.1

Address: 28 Genting Lane, #09-03/4/5 Platinum 28, Singapore 349585

Tel : +65-6493 5035

Fax : +65-6493 5037

Website: <http://www.flexxon.com>

Email: flexxon@flexxon.com

ALL RIGHTS ARE STRICTLY RESERVED. ANY PORTION OF THIS PAPER SHALL NOT BE REPRODUCED, COPIED, OR TRANSLATED TO ANY OTHER FORMS WITHOUT PERMISSION FROM FLEXXON.

TABLE OF CONTENTS

1.	GENERAL DESCRIPTION	3
1.1.	Introduction	3
1.2	Product Overview.....	3
2.	PRODUCT SPECIFICATIONS.....	4
2.1.	Performance	4
2.2.	Power	4
2.3.	DWPD (Drive Write Per Day)	4
2.4.	MTBF.....	5
2.5.	Data Retention	5
3.	ENVIRONMENTAL SPECIFICATIONS	6
4.	SUPPORTED COMMANDS	7
5.	PIN ASSIGNMENT.....	8
6.	PHYSICAL DIMENSION.....	11
7.	ORDERING INFORMATION	12

1. GENERAL DESCRIPTION



1.1. Introduction

FLEXXON's Enterprise EMP I PRO U.2 PCIe SSD has PCIe Gen4x4 interface, and is fully compliant with NVMe 1.4 industrial standard. It supports ultimate performance, high density and great reliability, suitable for enterprise application.

1.2 Product Overview

- ❖ **Capacity**
 - 3.2TB~ 12.8TB
- ❖ **Flash**
 - 3D NAND
- ❖ **PCIe Interface**
 - PCIe Gen4 x4 lanes
 - Compliant with NVMe 1.4a
 - Compatible with PCIe I/II/III x4 interface
- ❖ **ECC Scheme**
 - LDPC (Low Density Parity Check) of ECC algorithm
- ❖ **Dynamic and Static Wear Leveling**
- ❖ **Support SMART commands**
- ❖ **Power Loss Protection Algorithm**
- ❖ **Support AES 256/TCG OPAL (Optional)**
- ❖ **RAID**
- ❖ **Temperature Range**
 - Operation: 0°C ~ 70°C
 - Storage: -40°C ~ 85°C
- ❖ **RoHS Compliant**

2. PRODUCT SPECIFICATIONS



2.1. Performance

Table 2-1 Sustained Performance of EMP I PRO U.2 PCIe SSD

Capacity	Sequential	
	Read (MB/s)	Write (MB/s)
3.2TB ~ 12.8TB	7,500	6,000

NOTES:

1. Performance may differ according to flash configuration and platform.

2.2. Power

Table 2-2 Supply Voltage of EMP I PRO U.2 PCIe SSD

Parameter	Rating
Operating Voltage	12V

Table 2-3 Power Consumption of EMP I PRO U.2 PCIe SSD

Capacity	Power Consumption, W	
	Maximum	Idle
3.2TB ~ 12.8TB	18.0	5.0

2.3. DWPD (Drive Write Per Day)

Capacity	DWPD
3.2TB	3
6.4TB	3
12.8TB	3

2.4. MTBF

MTBF, an acronym for Mean Time Between Failures, is a measure of a device's reliability. Its value represents the average time between a repair and the next failure. The predicted result of FLEXXON's EMP I PRO PCIe U.2 SSD is more than 2 million hours.

2.5. Data Retention

- 10 years if > 90% life remaining (@25C)
- 1 year if < 10% life remaining (@25C)

FLEXXON CONFIDENTIAL

3. ENVIRONMENTAL SPECIFICATIONS



Test Items	Test Conditions
Storage Temperature	-40°C ~ 85°C
Operating Temperature	0°C ~ 70°C
Storage Humidity	40°C, 95% RH
Operating Humidity	40°C, 95% RH
Shock	1000G, Half Sin Pulse Duration 0.5ms
Vibration	2.17Grms (5~700Hz)
ESD	+/-8KV

4. SUPPORTED COMMANDS



Table 4-1 NVMe Management Interface Command Set support

Identifier	Command	Support
00h	Read NVMe-MI Data Structure	YES
01h	NVM Subsystem Health Status Poll	YES
02h	Controller Health Status Poll	YES
03h	Configuration Set	YES
04h	Configuration Get	YES
05h	VPD Read	YES
06h	VPD Write	NO
07h	Reset	NO
08h	SES Receive	NO
09h	SES Send	NO
0Ah	Management Endpoint Buffer Read	NO
0Bh	Management Endpoint Buffer Write	NO
0Ch to BFh	Reserved	NO
C0h to FFh	Vendor specific	NO

5. PIN ASSIGNMENT

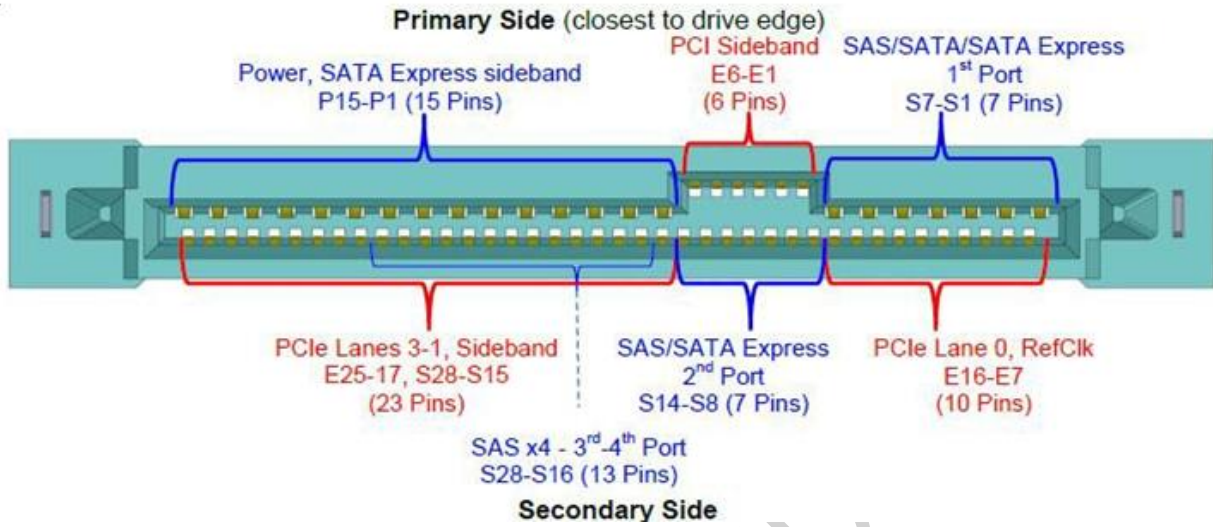

Figure 5-1 EMP I PRO U.2 PCIe SSD Pin Locations

Table 5-1 U.2 PCIe SSD SFF-8639 Connector Pin Assignment and Descriptions

Pin Number	Name	Description
P1	NC	
P2	NC	
P3	NC	
P4	IfDet#	Interface type Detect
P5	GND	Ground
P6	GND	Ground
P7	NC	
P8	NC	
P9	NC	
P10	PRSNT#	Presence detect
P11	ACTIVITY#	Activity indicator
P12	GND	Ground
P13	+12V Precharge	+12V Precharge POWER
P14	+12V	12V POWER
P15	+12V	12V POWER
S1	GND	Ground
S2	NC	
S3	NC	
S4	GND	Ground

Pin Number	Name	Description
S5	NC	
S6	NC	
S7	GND	Ground
S8	GND	Ground
S9	NC	
S10	NC	
S11	GND	Ground
S12	NC	
S13	NC	
S14	GND	Ground
S15	RSVD	Reserved
S16	GND	Ground
S17	PETp1	Transmitter differential pair, Lane 1
S18	PETn1	Transmitter differential pair, Lane 1
S19	GND	Ground
S20	PERn1	Receiver differential pair, Lane 1
S21	PERp1	Receiver differential pair, Lane 1
S22	GND	Ground
S23	PETp2	Transmitter differential pair, Lane 2
S24	PETn2	Transmitter differential pair, Lane 2
S25	GND	Ground
S26	PERn2	Receiver differential pair, Lane 2
S27	PERp2	Receiver differential pair, Lane 2
S28	GND	Ground
E1	REFCLK1+	Reference clock for dual port
E2	REFCLK1-	Reference clock for dual port
E3	+3.3 Vaux	3.3 V auxiliary power
E4	PERST1# / CLKREQ	Fundamental reset for dual port, Clkreq for signal port
E5	PERST0#	Fundamental reset
E6	RSVD	Reserved
E7	REFCLK0+	Reference clock
E8	REFCLK0-	Reference clock
E9	GND	Ground
E10	PETp0	Transmitter differential pair, Lane 0
E11	PETn0	Transmitter differential pair, Lane 0
E12	GND	Ground

Pin Number	Name	Description
E13	PERn0	Receiver differential pair, Lane 0
E14	PERp0	Receiver differential pair, Lane 0
E15	GND	Ground
E16	RSVD	Reserved
E17	PETp3	Transmitter differential pair, Lane 3
E18	PETn3	Transmitter differential pair, Lane 3
E19	GND	Ground
E20	PERn3	Receiver differential pair, Lane 3
E21	PERp3	Receiver differential pair, Lane 3
E22	GND	Ground
E23	SMBCLK	SMBus (System Management Bus) clock
E24	SMBDAT	SMBus (System Management Bus) data
E25	DualPortEn#	Dual-port Enable

FLEXON CONFIDENTIAL

6. PHYSICAL DIMENSION



Dimension: 100.2mm(L) x 69.9mm(W) x 14.80mm(H)

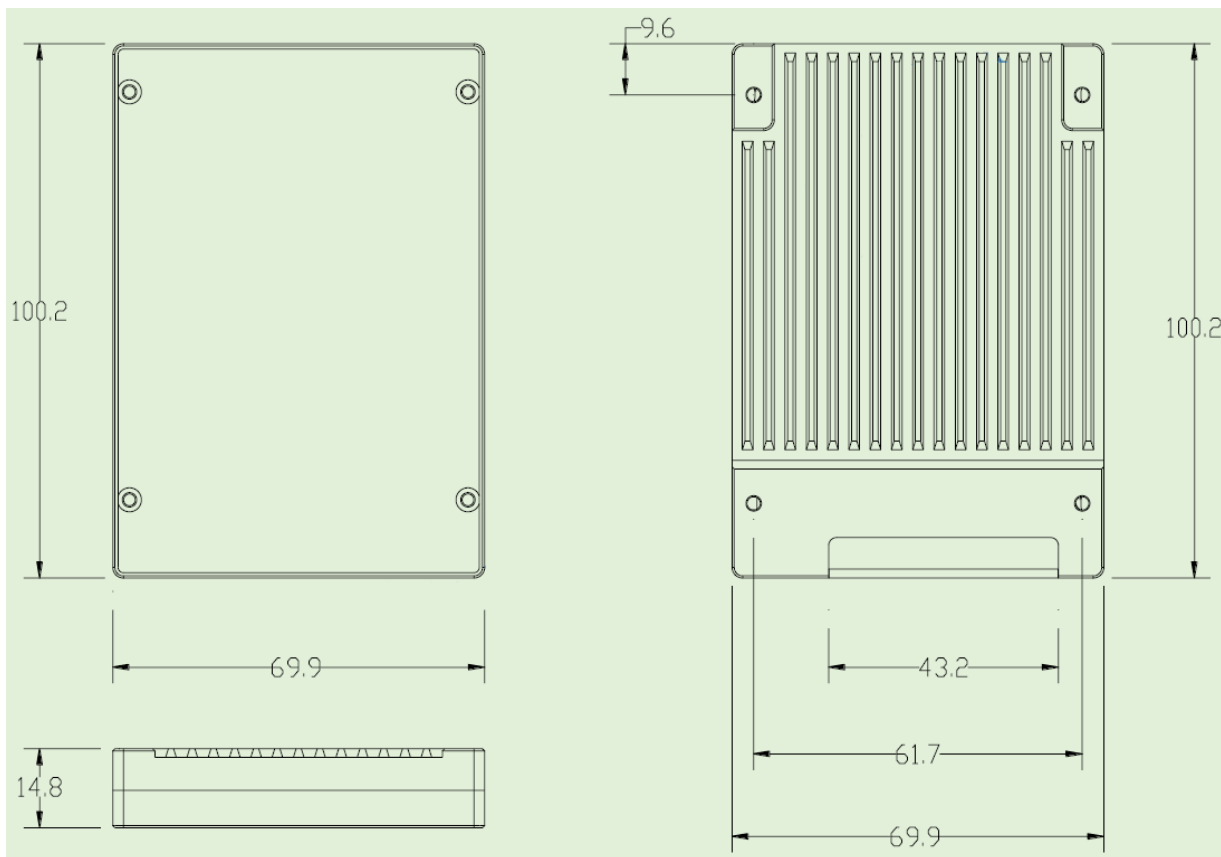

FLEXXON

7. ORDERING INFORMATION



Capacity	MPN
3.2TB	FCCB3200BC-FD00
6.4TB	FCCB6400BC-FD00
12.8TB	FCCB128TBC-FD00

FLEXXON CONFIDENTIAL

Revision History

Revision	Date	Description
1.0	2022/06	Preliminary release
1.1	2022/07	Update product information

FLEXXON CONFIDENTIAL