

# FR60 FAMILY

## SOCKET ADAPTER BOARD

# EMA-MB91F467D-LS-208M04

---

## USER GUIDE

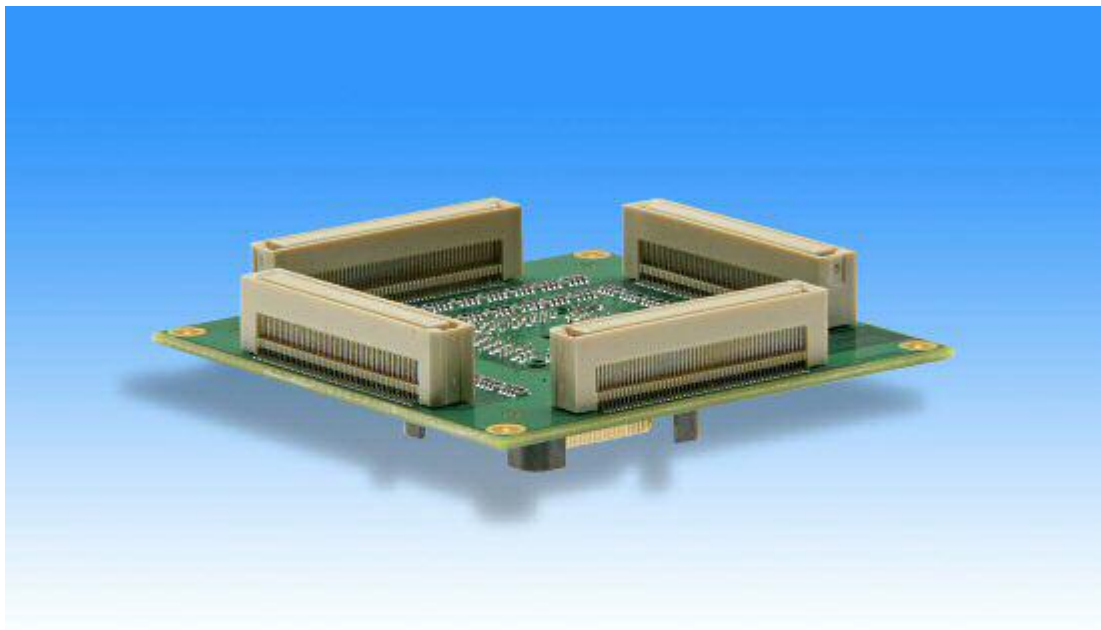

## Revision History

Date	Issue
12.09.2006	V1.00, RH/AW First Release
10.10.2006	V1.01, AW J490 bug: Do not set J490:2-3
16.10.2006	V1.02, AW Jumper description, default settings
09.03.2007	V1.1, MB/RW New hardware revision
30.03.2007	V1.2, MB UG-910030-11-EMA-MB91F467D-LS-208M04-corr-x1-00 corrections added
17.04.2007	A 33 pf capacitor is connected between MCLKO (R438) and GND.
29.05.2007	V1.3, chapter 1.3 added, amendment to figure 3.1
30.05.2007	V1.4, chapter 7 added
08.01.2008	V1.5, CPLD code changed, chapter 4.2 and chapter 5 changed
11.04.2008	V1.6, China RoHS note added, new format of CPLD code, S401-9 added
25.04.2008	V1.7, page 16: "The port P03 and P04..." -> "The port P03 and P02..." and CPLD code comments changed
26.05.2008	V1.8, CPLD code spelling fixed (identical behaviour)
29.09.2008	V1.9, CEy Some minor corrections
16.01.2009	V2.0, CEy Description for EMA-MB91FV460B-001 added

Latest product revision: 1.1  
Schematic version: 2.5  
PCB version: 3.0  
CPLD version: 7D12

This document contains 34 pages.

## Warranty and Disclaimer

To the maximum extent permitted by applicable law, Fujitsu Microelectronics Europe GmbH restricts its warranties and its liability for **the EMA-MB91F467D-LS-208M04 Board and all its deliverables** (e.g. software include or header files, application examples, target boards, evaluation boards, engineering samples of IC's etc.), its performance and any consequential damages, on the use of the Product in accordance with (i) the terms of the License Agreement and the Sale and Purchase Agreement under which agreements the Product has been delivered, (ii) the technical descriptions and (iii) all accompanying written materials. In addition, to the maximum extent permitted by applicable law, Fujitsu Microelectronics Europe GmbH disclaims all warranties and liabilities for the performance of the Product and any consequential damages in cases of unauthorised decompiling and/or reverse engineering and/or disassembling. **Note, the EMA-MB91F467D-LS-208M04 Board and all its deliverables are intended and must only be used in an evaluation laboratory environment.**

1. Fujitsu Microelectronics Europe GmbH warrants that the Product will perform substantially in accordance with the accompanying written materials for a period of 90 days from the date of receipt by the customer. Concerning the hardware components of the Product, Fujitsu Microelectronics Europe GmbH warrants that the Product will be free from defects in material and workmanship under use and service as specified in the accompanying written materials for a duration of 1 year from the date of receipt by the customer.
2. Should a Product turn out to be defect, Fujitsu Microelectronics Europe GmbH's entire liability and the customer's exclusive remedy shall be, at Fujitsu Microelectronics Europe GmbH's sole discretion, either return of the purchase price and the license fee, or replacement of the Product or parts thereof, if the Product is returned to Fujitsu Microelectronics Europe GmbH in original packing and without further defects resulting from the customer's use or the transport. However, this warranty is excluded if the defect has resulted from an accident not attributable to Fujitsu Microelectronics Europe GmbH, or abuse or misapplication attributable to the customer or any other third party not relating to Fujitsu Microelectronics Europe GmbH.
3. To the maximum extent permitted by applicable law Fujitsu Microelectronics Europe GmbH disclaims all other warranties, whether expressed or implied, in particular, but not limited to, warranties of merchantability and fitness for a particular purpose for which the Product is not designated.
4. To the maximum extent permitted by applicable law, Fujitsu Microelectronics Europe GmbH's and its supplier's liability are restricted to intention and gross negligence.

### **NO LIABILITY FOR CONSEQUENTIAL DAMAGES**

**To the maximum extent permitted by applicable law, in no event shall Fujitsu Microelectronics Europe GmbH and its suppliers be liable for any damages whatsoever (including but without limitation, consequential and/or indirect damages for personal injury, assets of substantial value, loss of profits, interruption of business operation, loss of information, or any other monetary or pecuniary loss) arising from the use of the Product.**

Should one of the above stipulations be or become invalid and/or unenforceable, the remaining stipulations shall stay in full effect

## 0 Contents

<b>REVISION HISTORY .....</b>	<b>2</b>
<b>WARRANTY AND DISCLAIMER .....</b>	<b>3</b>
<b>0 CONTENTS.....</b>	<b>4</b>
<b>1 OVERVIEW.....</b>	<b>6</b>
1.1 Abstract.....	6
1.2 General Description.....	7
1.3 Functional Restrictions .....	8
1.3.1 Valid for EMA-MB91V460A-002B/-80/003 and EMA-MB91FV460B-001....	8
<b>2 INSTALLATION .....</b>	<b>9</b>
<b>3 SWITCHES AND JUMPERS.....</b>	<b>10</b>
3.1 Switches and Jumpers overview .....	10
3.1.1 External bus data.....	10
3.1.2 Bus control.....	11
3.1.3 DMA control.....	11
3.1.4 Level Shifter direction / CS / MONCLK .....	12
3.2 Default Jumper Setting .....	13
3.3 MONCLK select (S400-10).....	15
3.4 Level-shifter direction control jumper.....	15
3.5 Data bus jumpers (D0-D15).....	16
3.5.1 D0 (P03_0).....	16
3.5.2 D1 (P03_1).....	16
3.5.3 D2 (P03_2).....	16
3.5.4 D3 (P03_3).....	16
3.5.5 D4 (P03_4).....	17
3.5.6 D5 (P03_5).....	17
3.5.7 D6 (P03_6).....	17
3.5.8 D7 (P03_7).....	17
3.5.9 D8 (P02_0).....	17
3.5.10 D9 (P02_1).....	18
3.5.11 D10 (P02_2).....	18
3.5.12 D11 (P02_3).....	18
3.5.13 D12 (P02_4).....	19
3.5.14 D13 (P02_5).....	19

3.5.15	D14 (P02_6)	19
3.5.16	D15 (P02_7)	19
<b>3.6</b>	<b>Bus control jumpers</b>	<b>20</b>
3.6.1	CS0# (P09_0)	20
3.6.2	CS1# (P09_1)	20
3.6.3	CS2# (P09_2)	20
3.6.4	CS3# (P09_3)	20
3.6.5	CS6# (P09_6)	20
3.6.6	CS7# (P09_7)	21
3.6.7	AS# (P10_1)	21
3.6.8	RDY (P08_7)	21
3.6.9	BGRNT# (P08_5)	21
3.6.10	BRQ (P08_6)	21
3.6.11	BAA# (P10_2)	22
3.6.12	WE# (P10_3)	22
<b>3.7</b>	<b>DMA jumpers</b>	<b>22</b>
3.7.1	DREQ0 (P13_0)	22
3.7.2	DACK0# (P13_1)	22
3.7.3	DEOP0 (P13_2)	22
<b>4</b>	<b>CPLD</b>	<b>23</b>
4.1	CPLD Verilog Code	23
4.2	CPLD Constraints	26
4.3	CPLD control settings	27
4.3.1	Product revision 1.1 (CPLD revision 7D12)	27
4.3.2	Product revision 1.0 (CPLD revision 7D11)	28
4.4	CPLD programming jumper (J491)	29
<b>5</b>	<b>MECHANICAL DIMENSIONS</b>	<b>30</b>
<b>6</b>	<b>INFORMATION IN THE WWW</b>	<b>31</b>
<b>7</b>	<b>CHINA-ROHS REGULATION</b>	<b>32</b>
<b>8</b>	<b>RECYCLING</b>	<b>34</b>

# 1 Overview

## 1.1 Abstract

The EMA-MB91F467D-LS-208M04 in combination with the EMA-MB91V460A-002B/-80/003 or EMA-MB91FV460B-001 is a development system for the Fujitsu FR60 MB91V460 Flash microcontroller.

The EMA-MB91F467D-LS-208M04 is an adapter board with level shifters to support the MB91V460A external bus interface at 3.3V levels.

The development system allows the designer immediately to start with the software development before MB91V460 based silicon samples are available.

**This board must only be used for test applications  
in an evaluation laboratory environment.**

Before using the EMA-MB91F467D-LS-208M04 adapter board, make sure that the following packed components have been delivered:

- 1 pcs. EMA-MB91F467D-LS-208M04 socket adapter board
- 1 pcs. YQPACK208SD
- 5 pcs. Screw M2x12
- 5 pcs. Washer M2, Nylon
- 1 pcs. User Guide

### **Note for SDRAM usage**

The EMA-MB91F467D-LS-208M04 supports external SRAM, Flash memory and SDRAM. Please refer to section 4 for further details.

Because of the additional delay of the level shifter the bus clock (CLKT) is limited to 32 MHz while SDRAM is connected to the external bus.

SDRAM	SRAM	Flash	CLKT restriction
		X	No restriction
	X		No restriction
	X	X	No restriction
X		X	CLKT <= 32 MHz
X	X		CLKT <= 32 MHz
X	X	X	CLKT <= 32 MHz

## 1.2 General Description

The EMA-MB91F467D-LS-208M04 in combination with the EMA-MB91V460A-002B/-80/003 or EMA-MB91FV460B-001 replaces a MB91F467D microcontroller. For further details of the EMA-MB91V460A-002B/-80/003 or EMA-MB91FV460B-001 board please refer to the User Guide of the EMA-MB91V460A-002B/-80/003 or EMA-MB91FV460B-001.

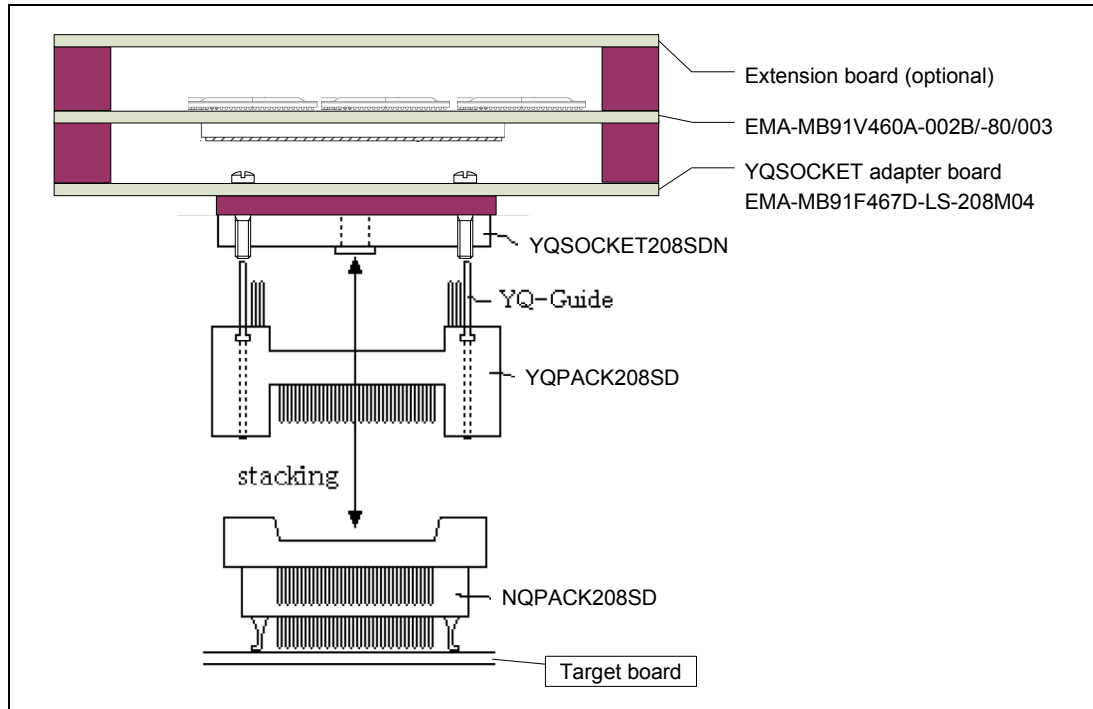

Figure 1-1: System overview

## 1.3 Functional Restrictions

### 1.3.1 Valid for EMA-MB91V460A-002B/-80/003 and EMA-MB91FV460B-001

This probe cable can only be used for the following Microcontroller configuration:

1. VDD5 = 5V, VDD35 = 3.3V

The following Microcontroller configurations (2 & 3) are applicable with this probe cable, but it is recommended to use the appropriate MCU "NLS" probe cable!

2. VDD5 = 5V, VDD35 = 5V
3. VDD5 = 3.3V, VDD35 = 3.3V

While using this probe cable, the GPIO functionality on the external bus interface (VDD35 voltage domain) is restricted!

Unused external bus function pins (e.g. address lines) cannot be configured as general purpose in- or output randomly!

The following ports or pin-groups (1-4) can be configured, each as a permanent general purpose input OR output group.

1. P07[0..7]
2. P06[0..7]
3. P05[0..7]
4. P04[0..1], P10.6, P08[0..4]

It is only possible to configure the whole blocks as input OR output!

Configuring each pin of these ports separately as input or output is not applicable!

For details on how to configure the port input and output direction please see chapter 3.4 Level-shifter direction control jumper, chapter 3.5 Data bus jumpers (D0-D7) and chapter 3.6 Data bus jumpers (D8-D15)!

The following pins can be configured as permanent general purpose input OR output separately.

5. P09[0..3], P09[6..7], P10.1, P08.7, P08[5..6], P10[2..3], P13[0..2],  
P03[0..7], P02[0..7]

It is possible to configure the pins each as input OR output! Configuring each pin of these ports separately as input or output is applicable by adding or removing certain resistors and jumpers!

For details on how to configure the pins input and output direction please see chapter 3.7 Bus control jumpers and the corresponding schematics.



## 2 Installation

Remove carefully the EMA-MB91F467D-LS-208M04 board from the shipping carton and check if there are any damages.

Please refer to the attached document “NQPACK/ YQPACK/ HQPACK Technical Information” for installation of the socket adapter.

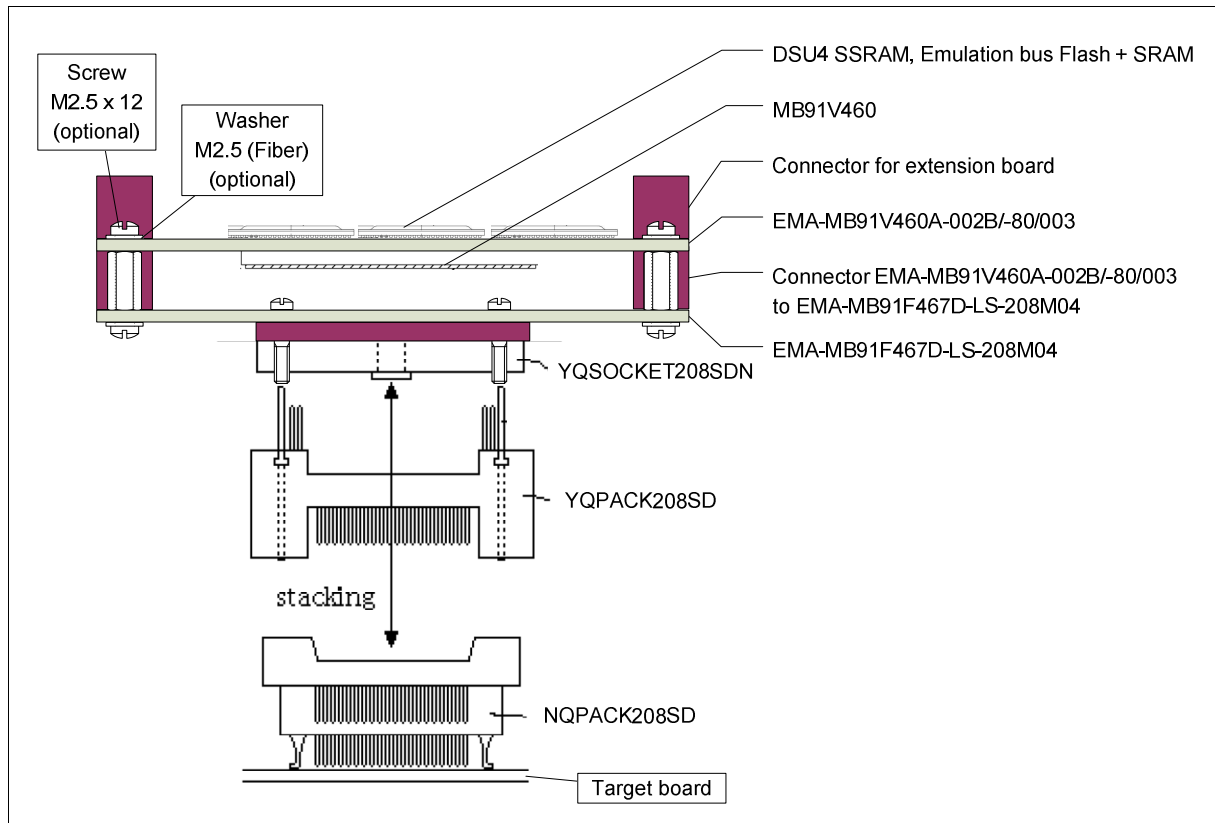

Figure 2-1: Installation

## 3 Switches and Jumpers

This chapter describes all switches and jumpers that can be modified or accessed on the EMA-MB91F467D-LS-208M04 board. The default setting is shown with a grey shaded area.

### 3.1 Switches and Jumpers overview

#### 3.1.1 External bus data

Jumper	Description/ Function	Type	Default
R400	P03_0 ⇔ D0, controlled by DIR_U400	0603	Closed
R401	P03_1 ⇔ D1, controlled by DIR_U400	0603	Closed
R402	P03_2 ⇔ D2, controlled by DIR_U400	0603	Closed
R403	P03_3 ⇔ D3, controlled by DIR_U400	0603	Closed
R404	P03_4 ⇔ D4, controlled by DIR_U400	0603	Closed
R405	P03_5 ⇔ D5, controlled by DIR_U400	0603	Closed
R406	P03_6 ⇔ D6, controlled by DIR_U400	0603	Closed
R407	P03_7 ⇔ D7, controlled by DIR_U400	0603	Closed
R408	P02_0 ⇔ D8, controlled by DIR_U401	0603	Closed
R409	P02_1 ⇔ D9, controlled by DIR_U401	0603	Closed
R410	P02_2 ⇔ D10, controlled by DIR_U401	0603	Closed
R411	P02_3 ⇔ D11, controlled by DIR_U401	0603	Closed
R412	P02_4 ⇔ D12, controlled by DIR_U401	0603	Closed
R413	P02_5 ⇔ D13, controlled by DIR_U401	0603	Closed
R414	P02_6 ⇔ D14, controlled by DIR_U401	0603	Closed
R415	P02_7 ⇔ D15, controlled by DIR_U401	0603	Closed
J423	D0 ⇔ P03_0	Jumper 2pol	Open
J422	D1 ⇔ P03_1	Jumper 2pol	Open
J421	D2 ⇔ P03_2	Jumper 2pol	Open
J420	D3 ⇔ P03_3	Jumper 2pol	Open
J419	D4 ⇔ P03_4	Jumper 2pol	Open
J418	D5 ⇔ P03_5	Jumper 2pol	Open
J417	D6 ⇔ P03_6	Jumper 2pol	Open
J416	D7 ⇔ P03_7	Jumper 2pol	Open
J424	D8 ⇔ P02_0	Jumper 2pol	Open
J425	D9 ⇔ P02_1	Jumper 2pol	Open
J426	D10 ⇔ P02_2	Jumper 2pol	Open
J427	D11 ⇔ P02_3	Jumper 2pol	Open
J428	D12 ⇔ P02_4	Jumper 2pol	Open
J429	D13 ⇔ P02_5	Jumper 2pol	Open
J430	D14 ⇔ P02_6	Jumper 2pol	Open
J431	D15 ⇔ P02_7	Jumper 2pol	Open

### 3.1.2 Bus control

Jumper	Description/ Function	Type	Default
R416	P09_0 ⇔ CS0#	0603	Closed
R417	P09_1 ⇔ CS1#	0603	Closed
R418	P09_2 ⇔ CS2#	0603	Closed
R419	P09_3 ⇔ CS3#	0603	Closed
R420	P09_6 ⇔ CS6#	0603	Closed
R421	P09_7 ⇔ CS7#	0603	Closed
R422	P10_1 ⇔ AS#	0603	Closed
R423	P08_7 ⇔ RDY	0603	Closed
R424	P08_5 ⇔ BGRNT#	0603	Closed
R425	P10_2 ⇔ BAA#	0603	Closed
R426	P10_3 ⇔ WE#	0603	Closed
R427	P08_6 ⇔ BRQ	0603	Closed
J439	P9_0 ⇔ CS0#	Jumper 2pol	Open
J440	P9_1 ⇔ CS1#	Jumper 2pol	Open
J441	P9_2 ⇔ CS2#	Jumper 2pol	Open
J442	P9_3 ⇔ CS3#	Jumper 2pol	Open
J443	P9_6 ⇔ CS6#	Jumper 2pol	Open
J444	P9_7 ⇔ CS7#	Jumper 2pol	Open
J445	P10_1 ⇔ AS#	Jumper 2pol	Open
J432	P08_7 ⇔ RDY	Jumper 2pol	Open
J467	P08_5 ⇔ BGRNT#	Jumper 2pol	Open
J469	P10_2 ⇔ BAA#	Jumper 2pol	Open
J470	P10_3 ⇔ WE#	Jumper 2pol	Open
J433	P08_6 ⇔ BRQ	Jumper 2pol	Open

### 3.1.3 DMA control

Jumper	Description/ Function	Type	Default
R456	P13_1 ⇔ DACK0#	0603	Closed
R457	P13_2 ⇔ DEOP0	0603	Closed
R458	P13_0 ⇔ DREQ0	0603	Closed
J474	P13_1 ⇔ DACK0#	Jumper 2pol	Open
J475	P13_2 ⇔ DEOP0	Jumper 2pol	Open
J473	P13_0 ⇔ DREQ0	Jumper 2pol	Open

### 3.1.4 Level Shifter direction / CS / MONCLK

Switch	Description/ Function	Type	Default
S400-1	Direction U402	Dip-Switch	On
S400-2	Direction U403	Dip-Switch	On
S400-3	Direction U406	Dip-Switch	Off
S400-4	Direction U407	Dip-Switch	Off
S400-5	Direction U408	Dip-Switch	Off
S400-6	Direction U409	Dip-Switch	Off
S400-10	MONCLK	Dip-Switch	On
S401-1	CS select	Dip-Switch	Off
S401-2		Dip-Switch	Off
S401-3		Dip-Switch	Off
S401-4		Dip-Switch	On
S401-5	SDRAM select	Dip-Switch	Off
S401-6		Dip-Switch	Off
S401-7		Dip-Switch	Off
S401-8		Dip-Switch	On
S401-9	Mode U400, U401	Dip-Switch	Off

Refer to chapter 4.3 for version differences.

### 3.2 Default Jumper Setting

The following jumper setting is the default setting.

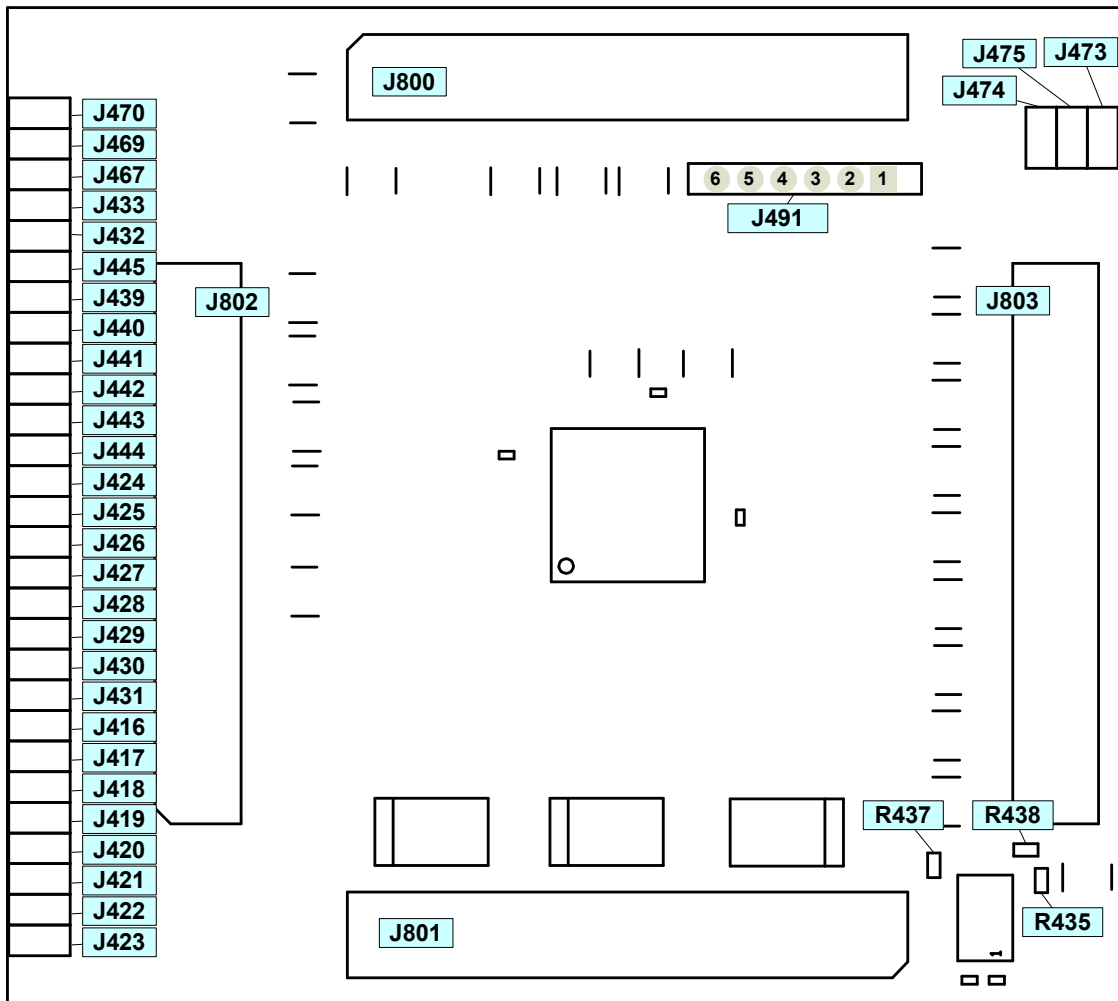

Figure 3-1: Jumper default setting, top

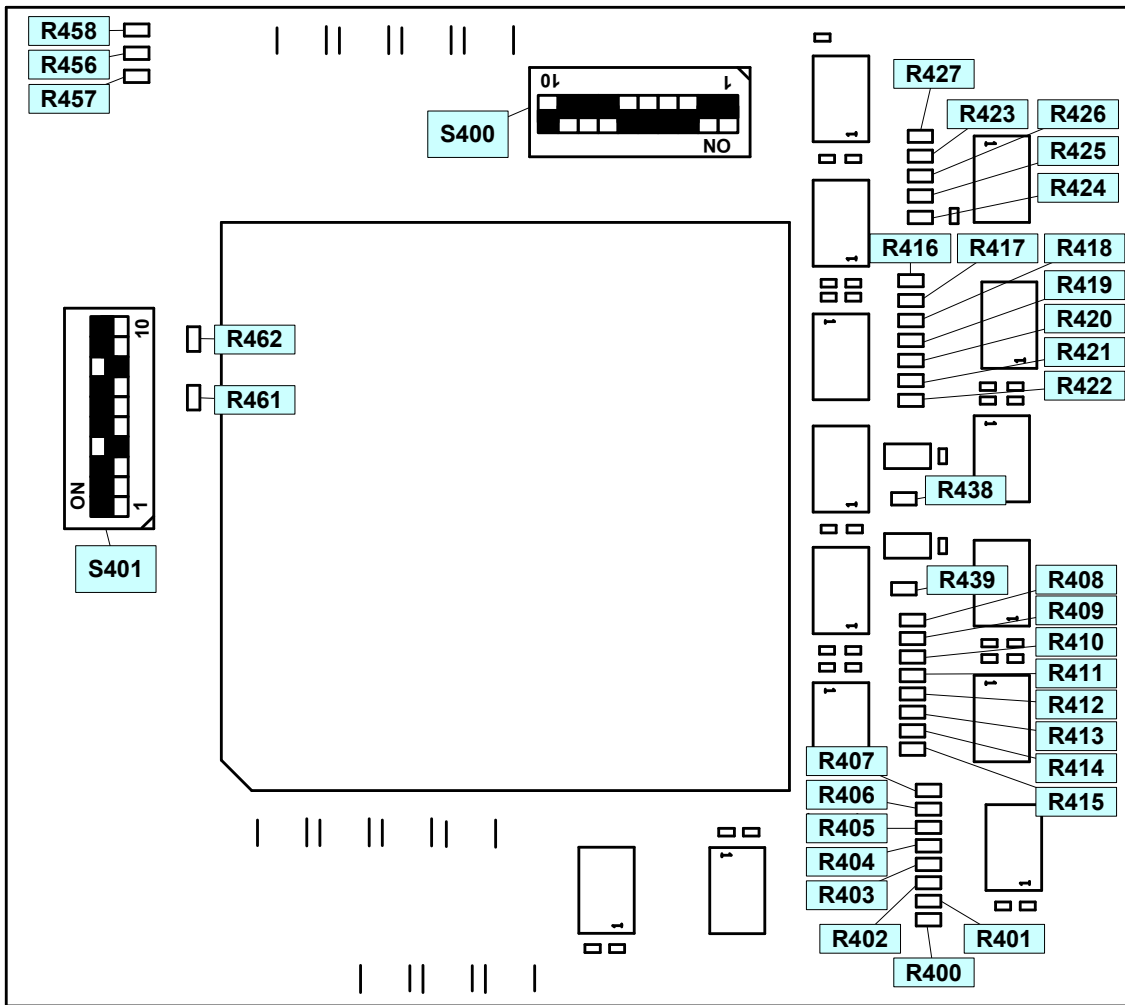

Figure 3-2: Jumper location, bottom. Refer to chapter 4.3 for version differences.

### 3.3 MONCLK select (S400-10)

Switch	Setting	Description
S400-10 (MONCLK)	OFF	No connection
	ON	MONCLK signal connected to the socket

Default: ON

### 3.4 Level-shifter direction control jumper

Jumper	Setting	Description
S400-1 (Direction U402)	ON	Target board D[0..7] ⇔ MB91V460 D[0..7] (check R400..R407 and J416..J423)
	OFF	Prohibited
S400-2 (Direction U403)	ON	Target board D[8..15] ⇔ MB91V460 D[8..15] (check R408..R415 and J424..J431)
	OFF	Prohibited
S400-3 (Direction U406)	ON	Target board A[0..7] ⇔ MB91V460 A[0..7]
	OFF	Target board A[0..7] ⇐ MB91V460 A[0..7]
S400-4 (Direction U407)	ON	Target board A[8..15] ⇔ MB91V460 A[8..15]
	OFF	Target board A[8..15] ⇐ MB91V460 A[8..15]
S400-5 (Direction U408)	ON	Target board A[16..23] ⇔ MB91V460 A[16..23]
	OFF	Target board A[16..23] ⇐ MB91V460 A[16..23]
S400-6 (Direction U409)	ON	Target board A[24..25], MCLKE, WR[0..3]#, RD# ⇔ MB91V460 A[24..25], MCLKE, WR[0..3]#, RD#
	OFF	Target board A[24..25], MCLKE, WR[0..3]#, RD# ⇐ MB91V460 A[24..25], MCLKE, WR[0..3]#, RD#

Default: S400-1, S400-2: ON; S400-3 to S400-6: OFF

### 3.5 Data bus jumpers (D0-D15)

The port P03 and P02 can be used as external bus interface (S401-9: OFF) or as general purpose I/O (S401-9: ON). See chapter 4.3.1.3 for further details.

For the general purpose I/O signals there are different directions selectable by J416 to J431 and R400 to R415.

#### 3.5.1 D0 (P03\_0)

R400	J423	Description
Closed	Open	P03_0 ⇔ D0 / external bus mode
Open	Closed	P03_0 ⇐ D0
Closed	Closed	Prohibited

Default: R400: Closed, J423: Open

#### 3.5.2 D1 (P03\_1)

R401	J422	Description
Closed	Open	P03_1 ⇔ D1 / external bus mode
Open	Closed	P03_1 ⇐ D1
Closed	Closed	Prohibited

Default: R401: Closed, J422: Open

#### 3.5.3 D2 (P03\_2)

R402	J421	Description
Closed	Open	P03_2 ⇔ D2 / external bus mode
Open	Closed	P03_2 ⇐ D2
Closed	Closed	Prohibited

Default: R402: Closed, J421: Open

#### 3.5.4 D3 (P03\_3)

R403	J420	Description
Closed	Open	P03_3 ⇔ D3 / external bus mode
Open	Closed	P03_3 ⇐ D3
Closed	Closed	Prohibited

Default: R403: Closed, J420: Open



### 3.5.5 D4 (P03\_4)

R404	J419	Description
Closed	Open	P03_4 ⇒ D4 / external bus mode
Open	Closed	P03_4 ⇐ D4
Closed	Closed	Prohibited

Default: R404: Closed, J419: Open

### 3.5.6 D5 (P03\_5)

R405	J418	Description
Closed	Open	P03_5 ⇒ D5 / external bus mode
Open	Closed	P03_5 ⇐ D5
Closed	Closed	Prohibited

Default: R405: Closed, J418: Open

### 3.5.7 D6 (P03\_6)

R406	J417	Description
Closed	Open	P03_6 ⇒ D6 / external bus mode
Open	Closed	P03_6 ⇐ D6
Closed	Closed	Prohibited

Default: R406: Closed, J417: Open

### 3.5.8 D7 (P03\_7)

R407	J416	Description
Closed	Open	P03_7 ⇒ D7 / external bus mode
Open	Closed	P03_7 ⇐ D7
Closed	Closed	Prohibited

Default: R407: Closed, J416: Open

### 3.5.9 D8 (P02\_0)

R408	J424	Description
Closed	Open	P02_0 ⇒ D8 / external bus mode
Open	Closed	P02_0 ⇐ D8
Closed	Closed	Prohibited

Default: R408: Closed, J424: Open

### 3.5.10 D9 (P02\_1)

R409	J425	Description
Closed	Open	P02_1 ⇔ D9 / external bus mode
Open	Closed	P02_1 ⇔ D9
Closed	Closed	Prohibited

Default: R409: Closed, J425: Open

### 3.5.11 D10 (P02\_2)

R410	J426	Description
Closed	Open	P02_2 ⇔ D10 / external bus mode
Open	Closed	P02_2 ⇔ D10
Closed	Closed	Prohibited

Default: R410: Closed, J426: Open

### 3.5.12 D11 (P02\_3)

R411	J427	Description
Closed	Open	P02_3 ⇔ D11 / external bus mode
Open	Closed	P02_3 ⇔ D11
Closed	Closed	Prohibited

Default: R411: Closed, J427: Open

### 3.5.13 D12 (P02\_4)

R412	J428	Description
Closed	Open	P02_4 ⇔ D12 / external bus mode
Open	Closed	P02_4 ⇔ D12
Closed	Closed	Prohibited

Default: R412: Closed, J428: Open

### 3.5.14 D13 (P02\_5)

R413	J429	Description
Closed	Open	P02_5 ⇔ D13 / external bus mode
Open	Closed	P02_5 ⇔ D13
Closed	Closed	Prohibited

Default: R413: Closed, J429: Open

### 3.5.15 D14 (P02\_6)

R414	J430	Description
Closed	Open	P02_6 ⇔ D14 / external bus mode
Open	Closed	P02_6 ⇔ D14
Closed	Closed	Prohibited

Default: R414: Closed, J430: Open

### 3.5.16 D15 (P02\_7)

R415	J431	Description
Closed	Open	P02_7 ⇔ D15 / external bus mode
Open	Closed	P02_7 ⇔ D15
Closed	Closed	Prohibited

Default: R415: Closed, J431: Open

### 3.6 Bus control jumpers

#### 3.6.1 CS0# (P09\_0)

R416	J439	Description
Closed	Open	P09_0 ⇒ CS0#
Open	Closed	P09_0 ⇐ CS0#
Closed	Closed	Prohibited

Default: R416: Closed, J439: Open

#### 3.6.2 CS1# (P09\_1)

R417	J440	Description
Closed	Open	P09_1 ⇒ CS1#
Open	Closed	P09_1 ⇐ CS1#
Closed	Closed	Prohibited

Default: R417: Closed, J440: Open

#### 3.6.3 CS2# (P09\_2)

R418	J441	Description
Closed	Open	P09_2 ⇒ CS2#
Open	Closed	P09_2 ⇐ CS2#
Closed	Closed	Prohibited

Default: R418: Closed, J441: Open

#### 3.6.4 CS3# (P09\_3)

R419	J442	Description
Closed	Open	P09_3 ⇒ CS3#
Open	Closed	P09_3 ⇐ CS3#
Closed	Closed	Prohibited

Default: R419: Closed, J442: Open

#### 3.6.5 CS6# (P09\_6)

R420	J443	Description
Closed	Open	P09_6 ⇒ CS6#
Open	Closed	P09_6 ⇐ CS6#
Closed	Closed	Prohibited

Default: R420: Closed, J443: Open

### 3.6.6 CS7# (P09\_7)

R421	J444	Description
Closed	Open	P09_7 ⇔ CS7#
Open	Closed	P09_7 ⇐ CS7#
Closed	Closed	Prohibited

Default: R421: Closed, J444: Open

### 3.6.7 AS# (P10\_1)

R422	J445	Description
Closed	Open	P10_1 ⇔ AS#
Open	Closed	P10_1 ⇐ AS#
Closed	Closed	Prohibited

Default: R422: Closed, J445: Open

### 3.6.8 RDY (P08\_7)

R423	J432	Description
Closed	Open	P08_7 ⇐ RDY
Open	Closed	P08_7 ⇔ RDY
Closed	Closed	Prohibited

Default: R423: Closed, J432: Open

### 3.6.9 BGRNT# (P08\_5)

R424	J467	Description
Closed	Open	P08_5 ⇔ BGRNT#
Open	Closed	P08_5 ⇐ BGRNT#
Closed	Closed	Prohibited

Default: R424: Closed, J467: Open

### 3.6.10 BRQ (P08\_6)

R427	J433	Description
Closed	Open	P08_6 ⇐ BRQ
Open	Closed	P08_6 ⇔ BRQ
Closed	Closed	Prohibited

Default: R427: Closed, J433: Open

### 3.6.11 BAA# (P10\_2)

R425	J469	Description
Closed	Open	P10_2 ⇔ BAA
Open	Closed	P10_2 ⇐ BAA
Closed	Closed	Prohibited

Default: R425: Closed, J469: Open

### 3.6.12 WE# (P10\_3)

R426	J470	Description
Closed	Open	P10_3 ⇔ WE#
Open	Closed	P10_3 ⇐ WE#
Closed	Closed	Prohibited

Default: R426: Closed, J470: Open

## 3.7 DMA jumpers

### 3.7.1 DREQ0 (P13\_0)

R458	J473	Description
Closed	Open	P13_0 ⇐ DREQ0
Open	Closed	P13_0 ⇔ DREQ0
Closed	Closed	Prohibited

Default: R458: Closed, J473: Open

### 3.7.2 DACK0# (P13\_1)

R456	J474	Description
Closed	Open	P13_1 ⇔ DACK0#
Open	Closed	P13_1 ⇐ DACK0#
Closed	Closed	Prohibited

Default: R456: Closed, J474: Open

### 3.7.3 DEOP0 (P13\_2)

R457	J475	Description
Closed	Open	P13_2 ⇔ DEOP0
Open	Closed	P13_2 ⇐ DEOP0
Closed	Closed	Prohibited

Default: R457: Closed, J475: Open

## 4 CPLD

The CPLD Xilinx XC9536XL-5VQL44C controls the direction of the data bus.

### 4.1 CPLD Verilog Code

```

`timescale 1ns / 1ps
////////////////////////////////////////////////////////////////////////////////////////////////////////////////////////////////
// Company:      Accemic GmbH & Co. KG
// Engineer:     RH / AW
//
// Create Date:  03/03/2007
// Design Name:  EMA-MB91F467D-LS-208M04
// Module Name:  F467D
// Project Name:
// Target Devices: XC9536XL-5VQ44
// Tool versions: ISE 9.2
// Description:
//
// Dependencies:
//
// Revision:
// Revision      1.2
// Additional Comments:
//
// USERCODE:    7D12
//              ||| |__ Subversion
//              || |__ Version
//              ||__ Target 467D
//              **
//
////////////////////////////////////////////////////////////////////////////////////////////////////////////////////////////////

module EMA_MB91F467D_LS_208M04_V11_cpld_7D12 (
ECSx,
CSx,          // P09_7..P09_0
WRx,          // P08_3..P08_0
RDx,          // P08_4
ASx,          // P10_1
BAAx,        // P10_2
WEx,          // P10_3
IORDx,       // P11_0
IOWRx,       // P11_1
S401,
DIR_U400,
DIR_U401,
DIR_U404,
DIR_U405,
OEx_U400_U401,
OEx_U404_U405);

```

```

input ECSx;
input [7:0] CSx;
input [3:0] WRx;
input RDx;
input ASx;
input BAAx;
input WEx;
input IORDx;
input IOWRx;
input [9:1] S401;
output DIR_U400;
output DIR_U401;
output DIR_U404;
output DIR_U405;
output OEx_U400_U401;
output OEx_U404_U405;

reg OEx_U400_U401, OEx_U404_U405;
reg DIR_U400, DIR_U401, DIR_U404, DIR_U405;

reg SDRAM_SELECTEDx;

always @*
begin
  case (S401[4:1]) // CS_SELECT
    4'hF: // CS0
      OEx_U404_U405 = !ECSx | ( CSx[1] & CSx[2] & CSx[3] & CSx[4]
                               & CSx[5] & CSx[6] & CSx[7]);

    4'hE: // CS1
      OEx_U404_U405 = !ECSx | ( CSx[0] & CSx[2] & CSx[3] & CSx[4]
                               & CSx[5] & CSx[6] & CSx[7]);

    4'hD: // CS2
      OEx_U404_U405 = !ECSx | ( CSx[0] & CSx[1] & CSx[3] & CSx[4]
                               & CSx[5] & CSx[6] & CSx[7]);

    4'hC: // CS3
      OEx_U404_U405 = !ECSx | ( CSx[0] & CSx[1] & CSx[2] & CSx[4]
                               & CSx[5] & CSx[6] & CSx[7]);

    4'hB: // CS4
      OEx_U404_U405 = !ECSx | ( CSx[0] & CSx[1] & CSx[2] & CSx[3]
                               & CSx[5] & CSx[6] & CSx[7]);

    4'hA: // CS5
      OEx_U404_U405 = !ECSx | ( CSx[0] & CSx[1] & CSx[2] & CSx[3]
                               & CSx[5] & CSx[6] & CSx[7]);

    4'h9: // CS6
      OEx_U404_U405 = !ECSx | ( CSx[0] & CSx[1] & CSx[2] & CSx[3]
                               & CSx[4] & CSx[5] & CSx[7]);

    4'h8: // CS7
      OEx_U404_U405 = !ECSx | ( CSx[0] & CSx[1] & CSx[2] & CSx[3]
                               & CSx[4] & CSx[5] & CSx[6]);

    default: // all CS
      OEx_U404_U405 = !ECSx | ( CSx[0] & CSx[1] & CSx[2] & CSx[3]
                               & CSx[4] & CSx[5] & CSx[6] & CSx[7]);

  endcase

  OEx_U400_U401 = OEx_U404_U405 & S401[9];

```



```
case (S401[8:5]) // SDRAM_SELECT
  4'b1111: SDRAM_SELECTEDx = CSx[0];
  4'b1110: SDRAM_SELECTEDx = CSx[1];
  4'b1101: SDRAM_SELECTEDx = CSx[2];
  4'b1100: SDRAM_SELECTEDx = CSx[3];
  4'b1011: SDRAM_SELECTEDx = CSx[4];
  4'b1010: SDRAM_SELECTEDx = CSx[5];
  4'b1001: SDRAM_SELECTEDx = CSx[6];
  4'b1000: SDRAM_SELECTEDx = CSx[7];
  default: SDRAM_SELECTEDx = 1;
endcase

// check schematic for DIR level (different on LS boards)
DIR_U400 = (RDx & (!(SDRAM_SELECTEDx & WEx)) | !S401[9]);
DIR_U401 = (RDx & (!(SDRAM_SELECTEDx & WEx)) | !S401[9]);
DIR_U404 = RDx & (!(SDRAM_SELECTEDx & WEx);
DIR_U405 = RDx & (!(SDRAM_SELECTEDx & WEx);
end
endmodule
```

## 4.2 CPLD Constraints

```

NET "ASx" LOC = "P13" ;
NET "BAAx" LOC = "P14" ;
NET "CSx<0>" LOC = "P2" ;
NET "CSx<1>" LOC = "P1" ;
NET "CSx<2>" LOC = "P3" ;
NET "CSx<3>" LOC = "P5" ;
NET "CSx<4>" LOC = "P6" ;
NET "CSx<5>" LOC = "P7" ;
NET "CSx<6>" LOC = "P8" ;
NET "CSx<7>" LOC = "P12" ;
NET "DIR_U400" LOC = "P39" | SLEW = FAST ;
NET "DIR_U401" LOC = "P38" | SLEW = FAST ;
NET "DIR_U404" LOC = "P36" | SLEW = FAST ;
NET "DIR_U405" LOC = "P37" | SLEW = FAST ;
NET "ECSx" LOC = "P32" ;
NET "IORDx" LOC = "P18" ;
NET "IOWRx" LOC = "P19" ;
NET "OEx_U400_U401" LOC = "P34" | SLEW = FAST ;
NET "OEx_U404_U405" LOC = "P33" | SLEW = FAST ;
NET "RDx" LOC = "P44" ;
NET "S401<1>" LOC = "P31" ;
NET "S401<2>" LOC = "P30" ;
NET "S401<3>" LOC = "P29" ;
NET "S401<4>" LOC = "P28" ;
NET "S401<5>" LOC = "P27" ;
NET "S401<6>" LOC = "P23" ;
NET "S401<7>" LOC = "P22" ;
NET "S401<8>" LOC = "P21" ;
NET "S401<9>" LOC = "P20" ;
NET "WEx" LOC = "P16" ;
NET "WRx<0>" LOC = "P40" ;
NET "WRx<1>" LOC = "P41" ;
NET "WRx<2>" LOC = "P43" ;
NET "WRx<3>" LOC = "P42" ;

```

### 4.3 CPLD control settings

Because of the additional delay of the level shifter the bus clock (CLKT) is limited to 32 MHz while SDRAM is connected to the external bus.

#### 4.3.1 Product revision 1.1 (CPLD revision 7D12)

##### 4.3.1.1 CS# mask

Chip select signals, selected by S401-1 to S401-4, will not be routed towards the target hardware! For applications with extension board EMA-MB91V460A-300 or equivalent extension boards, please select and set the corresponding chip select signal (CSx) used for the extension board! Please also refer to the user guide of the extension board and to the settings on the extension board itself.

E.g. EMA-MB91V460A-300 is configured to use chip select CS3, please set S401-4,3,2,1 on EMA-MB91F467D-LS-208M04 to CS3 (OFF, OFF, ON, ON)!

In default setting all chip select signals are routed to the target hardware.

S401-4	S401-3	S401-2	S401-1	Description
OFF	OFF	OFF	OFF	CS0# is selected
OFF	OFF	OFF	ON	CS1# is selected
OFF	OFF	ON	OFF	CS2# is selected
OFF	OFF	ON	ON	CS3# is selected
OFF	ON	OFF	OFF	CS4# is selected
OFF	ON	OFF	ON	CS5# is selected
OFF	ON	ON	OFF	CS6# is selected
OFF	ON	ON	ON	CS7# is selected
ON	Don't care			None selected

Default: S401-3..1: OFF, S401-4: ON

#### 4.3.1.2 SDRAM CS select

S401-8	S401-7	S401-6	S401-5	Description
OFF	OFF	OFF	OFF	SDRAM on CS0# is selected
OFF	OFF	OFF	ON	SDRAM on CS1# is selected
OFF	OFF	ON	OFF	SDRAM on CS2# is selected
OFF	OFF	ON	ON	SDRAM on CS3# is selected
OFF	ON	OFF	OFF	SDRAM on CS4# is selected
OFF	ON	OFF	ON	SDRAM on CS5# is selected
OFF	ON	ON	OFF	SDRAM on CS6# is selected
OFF	ON	ON	ON	SDRAM on CS7# is selected
ON	Don't care			No SDRAM

Default: S401-7..5: OFF, S401-8: ON

Note, the bus clock for SDRAM is limited to 32 MHz.

#### 4.3.1.3 U400, U401 mode

The ports P02 and P03 can be used either as external bus D[15:0] or as bidirectional, general purpose I/Os.

S401-9	U400, U401 mode
ON	General purpose I/O mode
OFF	External bus mode

Default: S401-9: OFF (external bus mode)

#### 4.3.2 Product revision 1.0 (CPLD revision 7D11)

S401-1	SDRAM CS# channel
ON	CS6# ⇔ SDRAM, CS7# ⇔ non-SDRAM (SRAM, Flash)
OFF	CS7# ⇔ SDRAM, CS6# ⇔ non-SDRAM (SRAM, Flash)

Default: S401-1: ON (CS6)

#### 4.4 CPLD programming jumper (J491)

The CPLD is re-configurable by programming via J491. Please refer to [www.xilinx.com](http://www.xilinx.com) for details and tools for Xilinx CPLD configuration.

J491 pin	Name
1	GND
2	TDO
3	TCK
4	TMS
5	TDI
6	VREF

## 5 Mechanical dimensions

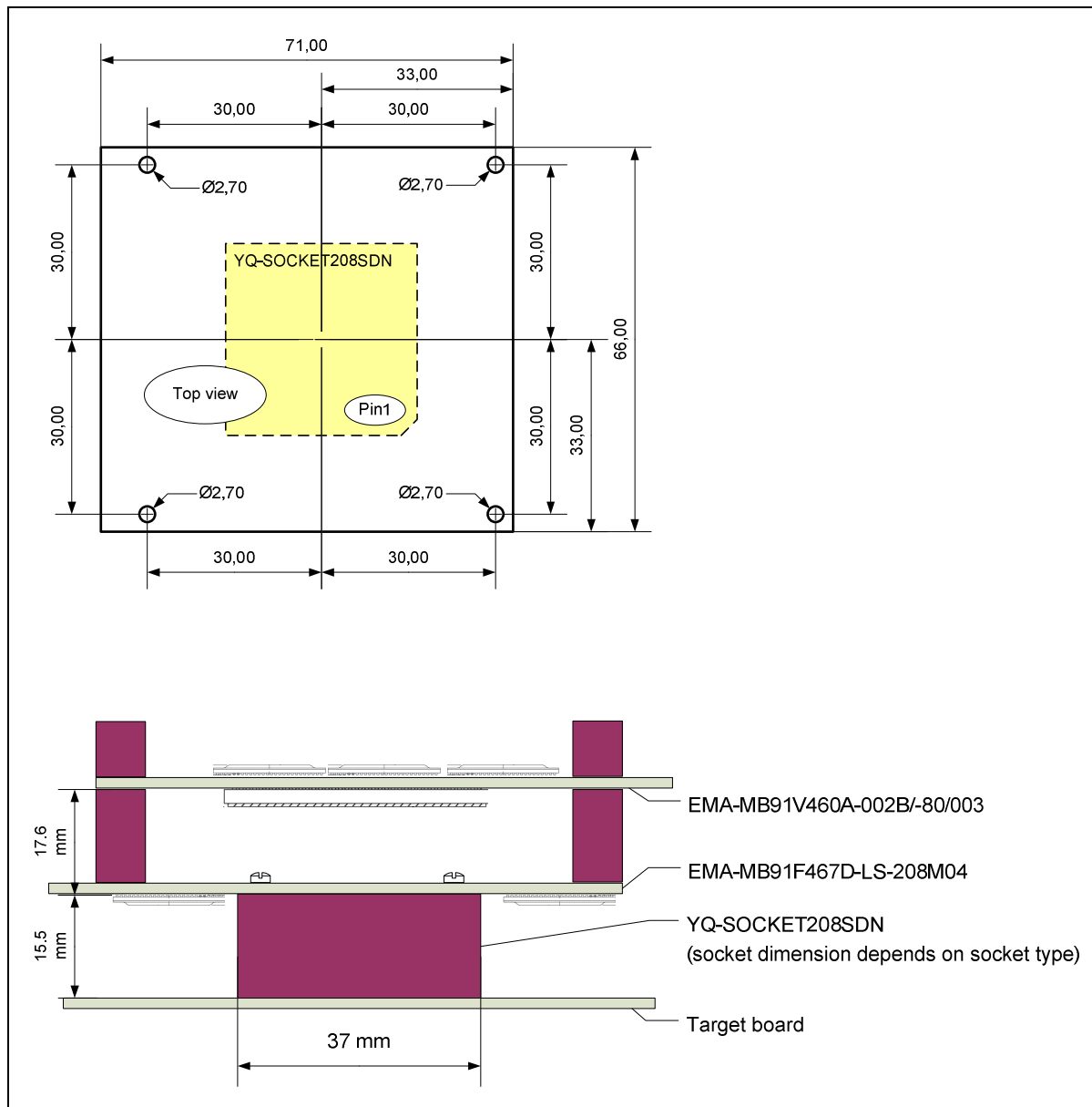

Figure 5-1: Mechanical dimensions

## 6 Information in the WWW

Information about FUJITSU MICROELECTRONICS Products can be found on the following Internet pages:

Microcontrollers (8-, 16- and 32bit), Graphics Controllers  
Datasheets and Hardware Manuals, Support Tools (Hard- and Software)

[http://mcu.emea.fujitsu.com/mcu\\_portal.htm](http://mcu.emea.fujitsu.com/mcu_portal.htm)

Linear Products: Power Management, A/D and D/A Converters

<http://www.fujitsu.com/emea/services/microelectronics>

Media Products: SAW filters, acoustic resonators and VCOs

<http://www.fujitsu.com/emea/services/microelectronics/saw>

For more information about FUJITSU MICROELECTRONICS

<http://www.fujitsu.com/emea/services/microelectronics>

## 7 China-RoHS regulation

**Evaluation Board** 评估板

**Emulation Board** 仿真板

根据SJ/T11364-

2006《电子信息产品污染控制标识要求》特提供如下有关污染控制方面的信息。

The following product pollution control information is provided according to SJ/T11364-2006 *Marking for Control of Pollution caused by Electronic Information Products*.

### 1. 电子信息产品污染控制标志说明 Explanation of Pollution Control Label



该标志表明本产品含有超过中国标准SJ/T11363-

2006《电子信息产品中有毒有害物质的限量要求》中限量的有毒有害物质。标志中的数字为本产品的环保使用期，表明本产品在正常使用的条件下，有毒有害物质不会发生外泄或突变，用户使用本产品不会对环境造成严重污染或对其人身、财产造成严重损害的期限，单位为年。

为保证所声明的环保使用期限，应按产品手册中所规定的环境条件和方法进行正常使用，并严格遵守产品维修手册中规定的定期维修和保养要求。

产品中的消耗件和某些零部件可能有其单独的环保使用期限标志，并且其环保使用期限有可能比整个产品本身的环保使用期限短。应到期按产品维修程序更换那些消耗件和零部件，以保证所声明的整个产品的环保使用期限。

本产品在使用寿命结束时不可作为普通生活垃圾处理，应被单独收集妥善处理。

请注意：环保使用期限50年的指定不是与产品的耐久力，使用期限或任何担保要求等同的。

This symbol to be added to all EIO sold to China, indicates the product contains hazardous materials in excess of the limits established by the Chinese standard SJ/T11363-2006 *Requirements for Concentration Limits for Certain Hazardous Substances in Electronic Information Products*. The number in the symbol is the Environment-friendly Use Period (EFUP), which indicates the period, starting from the manufacturing date, during which the toxic or hazardous substances or elements contained in electronic information products will not leak or mutate under normal operating conditions so that the use of such electronic information products will not result in any severe environmental pollution, any bodily injury or damage to any assets, the unit of the period is "Year".



In order to maintain the declared EFUP, the product shall be operated normally according to the instructions and environmental conditions as defined in the product manual, and periodic maintenance schedules specified in Product Maintenance Procedures shall be followed strictly.

Consumables or certain parts may have their own label with an EFUP value less than the product. Periodic replacement of those consumables or parts to maintain the declared EFUP shall be done in accordance with the Product Maintenance Procedures.

This product must not be disposed of as unsorted municipal waste, and must be collected separately and handled properly after decommissioning.

Please note: The designation of 10 years EFUP is not to be equated with the durability, use-duration or any warranty-claims of the product.

产品中有毒有害物质或元素的名称及含量

Table of hazardous substances name and concentration

部件名称 EMA-MB91F467D-LS-208M04	有毒有害物质或元素 Hazardous substances name					
	铅 (Pb)	汞 (Hg)	镉 (Cd)	六价铬 (Cr(VI))	多溴联苯 (PBB)	多溴二苯醚 (PBDE)
	x	o	o	o	o	o

O: 表示该有毒有害物质在该部件所有均质材料中的含量均在SJ/T11363-2006 标准规定的限量要求以下

X: 表示该有毒有害物质至少在该部件的某一均质材料中的含量超出SJ/T11363-2006 标准规定的限量要求

- 此表所列数据为发布时所能获得的最佳信息
- 由于缺少经济上或技术上合理可行的替代物质或方案，此医疗设备运用以上一些有毒有害物质来实现设备的预期临床功能，或给人员或环境提供更好的保护效果。

O: Indicates that this toxic or hazardous substance contained in all of the homogeneous materials for this part is below the limit requirement in SJ/T11363-2006.

X: Indicates that this toxic or hazardous substance contained in at least one of the homogeneous materials used for this part is above the limit requirement in SJ/T11363-2006.

- Data listed in the table represents best information available at the time of publication

## 8 Recycling

### **Gültig für EU-Länder:**

Gemäß der Europäischen WEEE-Richtlinie und deren Umsetzung in landesspezifische Gesetze nehmen wir dieses Gerät wieder zurück.

Zur Entsorgung schicken Sie das Gerät bitte an die folgende Adresse:

Fujitsu Microelectronics Europe GmbH  
Warehouse  
Monzastraße 4a  
63225 Langen

### **Valid for European Union Countries:**

According to the European WEEE-Directive and its implementation into national laws we take this device back.

For disposal please send the device to the following address:

Fujitsu Microelectronics Europe GmbH  
Warehouse  
Monzastraße 4a  
63225 Langen